



Electrovannes pour le contrôle des fluides

Catalogue général

aerospace
climate control
electromechanical
filtration
fluid & gas handling
hydraulics
pneumatics
process control
sealing & shielding



ENGINEERING YOUR SUCCESS.



> 5 000

Références produit

Ce catalogue est une liste complète des produits Parker FCDE. Il vous permet d'identifier les vannes et bobines appropriées et de générer les numéros de commande.

Ce catalogue s'adresse au personnel de vente Parker et a pour but d'aider celui-ci à sélectionner les électrovannes les plus appropriées pour les clients.



AVERTISSEMENT – RESPONSABILITE DE L'UTILISATEUR

LA DEFECTUOSITE OU LA SELECTION OU L'USAGE ABUSIF DES PRODUITS DECRITS DANS LE PRESENT DOCUMENT OU D'ARTICLES ASSOCIES PEUT ENTRAINDER LA MORT, DES BLESSURES ET DES DOMMAGES MATERIELS.

- Ce document et d'autres informations de Parker-Hannifin Corporation, ses filiales et distributeurs autorisés, proposent des options de produit et de système destinées aux utilisateurs possédant de solides connaissances techniques.
- En procédant à ses propres analyses et essais, l'utilisateur est seul responsable de la sélection définitive du système et des composants, au même titre qu'il lui incombe de veiller à la satisfaction des exigences en matière de performances, endurance, entretien, sécurité et avertissement. L'utilisateur doit analyser tous les aspects de l'application, suivre les normes applicables de l'industrie et les informations concernant le produit dans le catalogue de produits actuel et dans tout autre document fourni par Parker, ses filiales ou distributeurs agréés.
- Dans la mesure où Parker ou ses filiales ou distributeurs agréés fournissent des options de système ou de composant se basant sur les données ou les spécifications indiquées par l'utilisateur, c'est à celui-ci qu'incombe la responsabilité de déterminer si ces données et spécifications conviennent et sont suffisantes pour toutes les applications et utilisations raisonnablement prévisibles des composants ou des systèmes.

Qui sommes-nous ?

La division Fluid Control Europe (FCDE) est une division de Parker Hannifin, leader du secteur des technologies de mouvement et contrôle.

Les compétences de base de la division FCDE sont le développement et la fabrication d'une gamme de produits pour le contrôle des fluides comprenant électrovannes et régulateurs de pression.

Où sommes-nous ?

Notre siège européen est situé à Genève avec les activités R&D, marketing, support d'application, ainsi que la gestion des produits.

Les produits FCDE sont principalement fabriqués à Carouge (Genève, Suisse) et Gessate (Milan, Italie).

Les Parker Sales Companies ainsi que leur réseau de vente et service étendu vous soutiennent partout en Europe.

Histoire

Depuis plus de 60 ans maintenant, Parker FCDE est l'un des leaders dans la fabrication et le développement des technologies d'électrovannes. Grâce à une recherche et un développement continu l'entreprise a pu proposer des solutions innovantes au marché et introduire par exemple l'utilisation du rubis synthétique pour les applications critiques avec l'eau ou la fiabilité et la précision inégalées de nos régulateurs de pression. Le savoir-faire acquis et développé au cours des années se traduit par la très bonne qualité des solutions FCDE.

Les secteurs d'activité

Nos produits et solutions sont typiquement conçus pour des secteurs d'activité suivants : équipements industriels, automatisation industrielle, systèmes mobiles, transport, sciences de la vie, distributeurs de boissons et contrôle des fluides et des processus.

Avantages

La conception modulaire de nos produits intégrant des électrovannes et des parties électriques séparées offre aux clients une plus grande flexibilité en lui permettant d'effectuer de nombreuses combinaisons. Ce gain de flexibilité permet aux distributeurs de réduire davantage leur stock de vannes tout en maintenant les mêmes capacités. Parker bénéficie également d'une expérience hors pair dans le développement de produits sur mesure en conformité avec les plus strictes exigences techniques, environnementales, énergétiques et d'endurance.



PARKER FCDE - GENÈVE - SUISSE



PARKER FCDE - MILAN - ITALIE

CATALOGUE GÉNÉRAL FCDE

SOMMAIRE

INTRODUCTION

Les secteurs d'activité et les applications	06
Une gamme complète d'électrovannes	08
Un concept modulaire	10
Certification ATEX.....	12
Normes internationales	13
Comment utiliser ce catalogue	14
Comment choisir une vanne.....	16
Comment passer commande	18
Groupes électriques	24

ELECTROVANNES 2 VOIES

Electrovannes pour de l'air sec ou lubrifié, gaz et liquides neutres	27
Electrovannes pour eau et liquides neutres	79
Electrovannes anti-coup de bélier	113
Electrovannes pour eau chaude et vapeur	125
Electrovannes pour huile hydraulique et liquides neutres (jusqu'à 100 bar).....	141
Electrovannes à haute résistance à la corrosion (acier inoxydable 303).....	157
Electrovannes à haute résistance à la corrosion (acier inoxydable 316L)	165
Electrovannes pour brûleurs à fuel.....	177
Electrovannes à actionnement rapide.....	197
Electrovannes pour les distributeurs de boisson - Liquepure®	201

ELECTROVANNES 3 VOIES

Electrovannes pour air sec ou lubrifié, gaz et liquides neutres	207
Electrovannes pour huile hydraulique et liquides neutres (jusqu'à 75 bar)	247
Electrovannes à haute résistance à la corrosion (acier inoxydable 303).....	251
Electrovannes pour les distributeurs de boisson - Liquepure®	257

ELECTROVANNES 2 ET 3 VOIES POUR APPLICATION TRANSPORT

Electrovannes 2 voies	265
Electrovannes 3 voies	271

DISTRIBUTEURS 5 VOIES POUR APPLICATIONS PNEUMATIQUES

Distributeurs 5 voies pour commande d'actionneurs pneumatiques (Raccord tuyau/montage sur embase)	275
---	-----

DISTRIBUTEURS 3 ET 5 VOIES POUR COMMANDE D'ACTIONNEURS PNEUMATIQUES

Distributeurs à 3 et 5 voies pour commande d'actionneurs pneumatiques (Raccord tuyau).....	301
Distributeurs à 3 et 5 voies pour commande d'actionneurs pneumatiques (NAMUR).....	333
Distributeurs à 3 et 5 voies Inox 316L pour commande d'actionneurs pneumatiques (Raccord tuyau et NAMUR).....	375

MANIFOLD EEXPRESS COMMANDÉ PAR BUS POUR LA COMMANDE D'ACTIONNEURS

Manifold EExpress commandé par bus pour la commande d'actionneurs.....	407
--	-----

RÉGULATEURS DE PRESSION ÉLECTROPNEUMATIQUES

Série EPP4 : Basic, Comfort , Comfort ATEX	411
--	-----

BOBINES, BOÎTIERS ET PARTIES ÉLECTRIQUES

Introduction.....	443
Bobines.....	453
Parties électriques antidéflagrantes	489
Boîtiers.....	522
Accessoires de bobine.....	526
Environnements explosifs.....	528
Annexes pour bobines.....	538

INFORMATIONS TECHNIQUES CONCERNANT LES ÉLECTROVANNES

Informations techniques concernant les électrovannes	545
--	-----

ANNEXE

Tableau des embases pour vannes	566
Index par référence de valve.....	572
Index par N° de commande de valve.....	576

LES SECTEURS D'ACTIVITÉ ET LES APPLICATIONS

Afin de proposer aux clients la meilleure solution, Parker propose une gamme étendue de produits pour des secteurs d'activité différents :

COMMANDE DE PROCESS

- Actionnement de vanne
- Pétrole et gaz
- On-shore et off-shore
- Pétrochimie
- Pharmacie



INDUSTRIE ET AUTOMATISATION

- Compresseurs
- Soufflage
- Textile
- Régulation de pression



AGROALIMENTAIRE

- Machines à café professionnelles
- Eau gazeuse
- Boissons sans alcool
- Distribution d'eau



REFROIDISSEMENT ET CONDITIONNEMENT DE L'AIR

- Distribution d'eau
- Systèmes de refroidissement



TRANSPORT

- Camions
- Trains
- Bus et autocars
- Applications marines
- Militaire
- Agriculture



SCIENCES DE LA VIE

- Stérilisateurs/Autoclaves
- Respiration
- Purification de l'eau
- Équipements sur table



SYSTÈMES DE CHAUFFAGE

- Brûleurs à mazout industriels
- Transfert de combustible
- Transfert de gaz



UNE GAMME COMPLÈTE D'ÉLECTROVANNES POUR LE CONTRÔLE DES FLUIDES

VANNES À 2 VOIES

- Pour de l'air sec ou lubrifié, des gaz et liquides neutres
- Pour de l'eau et des liquides neutres
- Anti-coup de bélier
- Eau chaude et vapeur
- Pour de l'huile hydraulique et des liquides neutres (100 bar maxi.)
- Haute résistance à la corrosion (acier inoxydable 303) (acier inoxydable 316L)
- Brûleur à mazout
- Actionnement rapide
- Liquipure® pour les distributeurs de boisson



VANNES À 3 VOIES

- Pour de l'air sec ou lubrifié
- Pour de l'huile hydraulique et des liquides neutres (75 bar maxi.)
- Haute résistance à la corrosion (acier inoxydable 303)
- Liquipure® pour les distributeurs de boisson



VANNES À 2 ET 3 VOIES POUR LE TRANSPORT

- 2 voies, à commande directe et pilote
- 3 voies, à commande directe



DISTRIBUTEURS 5 VOIES POUR DES APPLICATIONS PNEUMATIQUES

- Montage tuyau
- Montage sur embase



DISTRIBUTEURS PNEUMATIQUES À 3 ET 5 VOIES POUR LA COMMANDE D'ACTIONNEURS

- Montage tuyau
- Interface NAMUR
- Acier inoxydable 316L (montage tuyau et avec interface NAMUR)



BOBINES ET PARTIES ÉLECTRIQUES

- Bobines
- Boîtiers
- Parties électriques antidéflagrantes



MANIFOLD EXPRESS COMMANDÉ PAR BUS POUR LA COMMANDE D'ACTIONNEURS

- Zone ATEX 1/21

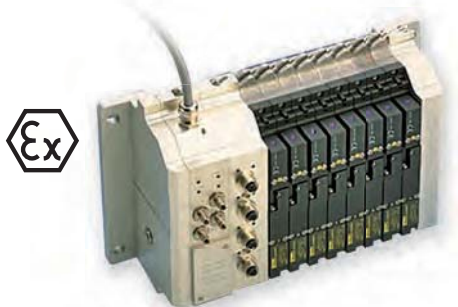

RÉGULATEURS DE PRESSION ÉLECTROPNEUMATIQUES SÉRIE EPP4

- Basic
- Comfort
- Comfort ATEX



UN CONCEPT MODULAIRE POUR CHAQUE APPLICATION

FAITES VOTRE CHOIX ENTRE :

Modes d'actionnement

- Commande directe
- Magnalift
- Commande pilote
- Réarmement manuelle
- Commande externe

Types de matériaux

- Laiton
- Acier inoxydable 303
- Acier inoxydable 316L
- Aluminium anodisé
- Alliage de zinc
- POM

Solutions de montage

- Tuyau
- Embase
- NAMUR
- Banjo
- CETOP
- ISO

Type de commande

- Normalement fermée
- Normalement ouverte
- Universelle
- Commande par impulsion électrique
- Électrovannes à double solénoïdes
- PWM

Conception interne

- Piston
- Clapet
- Membrane
- Tiroir

Joints

- FKM
- NBR
- EPDM
- Rubis
- PUR
- PCTFE...

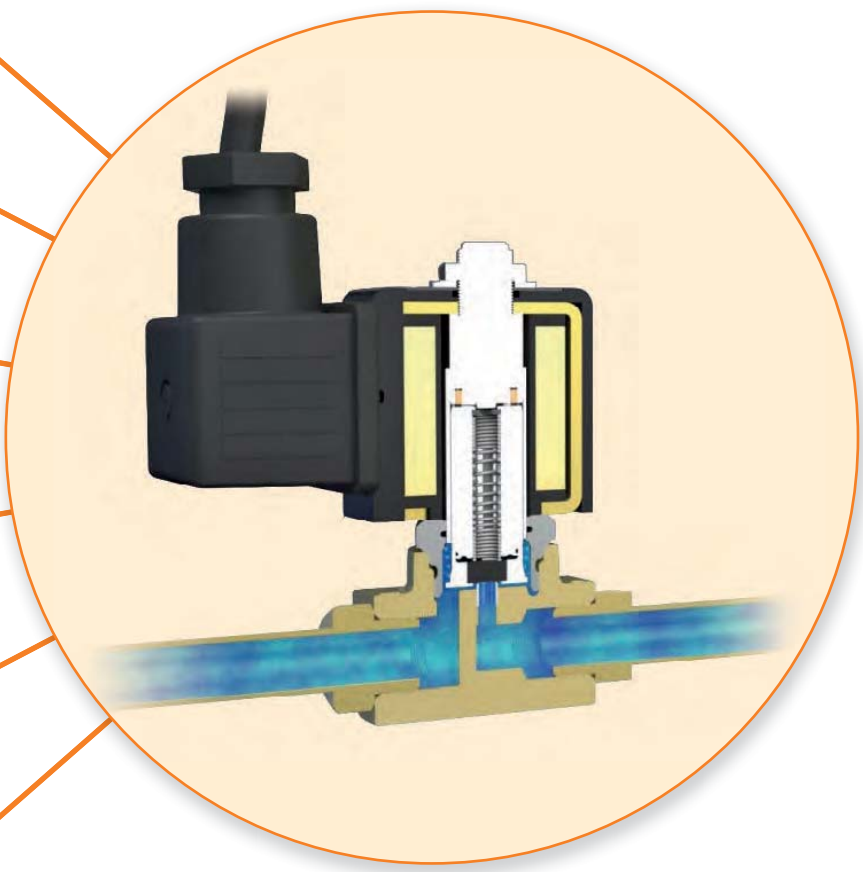



CERTIFICATION ATEX POUR DES PARTIES ÉLECTRIQUES

Une série de parties électriques FCDE correspondent à la directive 94/9/CE et sont destinées à des environnements potentiellement explosifs (zone 0/20, 1/21 et 2/22).

Dans le chapitre bobine, la présence du logo ATEX indique que la bobine est certifiée ATEX.



CERTIFICATION ATEX POUR DES PARTIES MÉCANIQUES

Une série de parties mécaniques FCDE correspondent aux stipulations de la directive 94/9/CE spécifiques aux équipements non électriques pour une utilisation dans des environnements potentiellement explosifs (zone 0/20, 1/21 et 2/22).

Les vannes NAMUR et à montage tuyau intègrent maintenant un marquage symbolisant la certification mécanique ATEX.

Dans le chapitre vanne, la présence du logo ATEX indique que la vanne est certifiée ATEX.



CERTIFICATION D'ÉLECTROVANNES

Lorsque la partie électrique ainsi que la partie mécanique sont certifiées ATEX, l'électrovanne peut être utilisée dans des atmosphères potentiellement explosives.

L'électrovanne est livrée entièrement assemblée et testée.

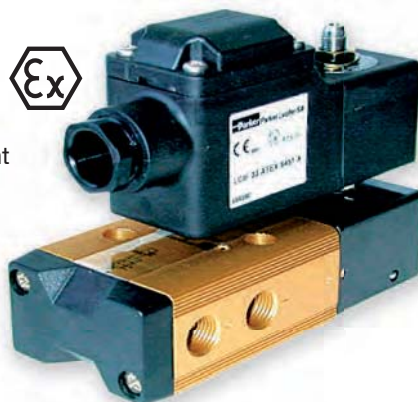

PARKER FCDE EST CONFORME AUX NORMES INTERNATIONALES

NORMES DE QUALITÉ :

- ISO 9001
- ISO 14001
- ISO TS 16949



CERTIFICATIONS ET HOMOLOGATIONS :

Nos produits ont été homologués et certifiés conformes aux exigences du marché, incluant :

- CE
- ATEX
- RoHS
- UL
- Reach
- IECEx
- CSA
- Gost
- SVGW
- DIN
- AGA
- TUV
- Kosha
- IMQ
- NSF
- VDE



COMMENT UTILISER CE CATALOGUE

Ce catalogue est une liste complète des produits Parker FCDE. Il vous permet d'identifier les vannes et bobines appropriées et de générer les numéros de commande. Ce catalogue s'adresse au personnel de vente Parker et a pour but d'aider celui-ci à sélectionner les électrovannes les plus appropriées pour les clients.

Le catalogue est classé par familles de produits. Chaque catégorie de vannes est précédée par une page de résumé. Pour simplifier l'utilisation, chaque catégorie de vanne est ensuite divisée en fonction des applications.

Sur la première page de chaque section d'application, vous trouvez une présentation des produits de cette application avec leurs caractéristiques techniques pour vous guider vers la page concernée (voir exemple ci-dessous) :

PAGE DE RÉSUMÉ DE SECTION

ELECTROVANNES 2 VOIES



ELECTROVANNES POUR AIR SEC
OU LUBRIFIÉ, GAZ ET LIQUIDES
NEUTRES



2/2

Commande	Corps de Valve	Fonction	Raccord	Orifice (mm)	Facteur d'Écoulement Kv(l/min)	Pression Différentielle (bar)	Temp. Max. (°C)	Page	Page		
								Annuaire Parker	Annuaire Parker "Lubrifié"		
Commande Directe	Laiton/Raccord bague	Ferme hors tension	1/8"	1.2 & 3	4.5	70	140	26	32		
			1/4"	1.2 & 6	13	100	140	30	36		
			3/8"	4 & 6	12	10	120	-	36		
		Ouvrte hors tension	1/8"	2.5	3.5	30	140	-	40	40	
			1/4"	1.5 & 3	4	40	140	38	40		
			1/4"	3 & 5	11	20	100	-	40		
Attraction forcée	Laiton/Montage sur embase	Ferme hors tension	5 mm	1.5 & 3	4.5	100	130	-	42		
			Ouvrte hors tension	5 mm	1.5	1.5	20	120	-	44	
			Laiton/Raccord bague	3/8"	13 & 15	65	20	140	46	48	
		1/2"		13 & 15	65	20	140	46	48		
		3/4"		15 & 20	100	30	140	46	50		
		Servo-commande	Laiton/Raccord bague	Ferme hors tension	1/4"	8 & 12	36	40	120	-	58
3/8"	11 & 13				50	40	120	54	58		
1/2"	13 & 15				60	40	120	54	60		
3/4"	15 & 20				135	40	120	54	62		
1"	18 & 28				270	16	120	54	64		
1 1/2"	40				425	16	120	-	66		
2"	40				540	16	120	-	66		
Ouvrte hors tension	1/4"				8	36	40	140	-	70	
	3/8"				11 & 13	50	40	120	68	70	
	1/2"				13 & 15	60	40	140	68	70	
	3/4"				15 & 20	135	40	120	70	72	
	1"				25 & 40	420	16	120	68	72	
	1 1/4"			28	270	16	120	-	72		
Commande par impulsion	1 1/2"			40	420	12	100	-	72		
	2"			40	540	12	120	-	72		
	1/4"			12	32	12	100	-	74		
	3/8"			12	45	12	100	-	74		
	1/2"			12	50	12	100	-	74		
	3/4"			18	100	12	100	-	74		
	1"			18	110	12	100	-	74		
	Laiton/Montage sur embase			Ferme hors tension	14 mm	14	45	40	140	-	76
					Ouvrte hors tension	14 mm	14	45	40	120	-

Familie de produits

Application

Nombre de voies/positions

Actionnement

Fluides applicables

Actionnement, corps et fonction

Corps

Montage

Fonction

Caractéristiques techniques

Page concernée

Pour plus d'informations techniques sur l'actionnement, le corps et la fonction, veuillez vous reporter à la section des informations techniques à la fin du catalogue.

Secteurs d'activité applicables pour cette catégorie de vanne

Certifications applicables sur cette page

Tableau pour choix rapide avec des valeurs mini/maxi pour toutes les vannes de la page

PAGE DE PRODUIT

ELECTROVANNES 2 VOIES

2/2" ELECTROVANNES POUR EAU CHAUDE ET VAPEUR
ATTRACTION FORCÉE

Equipment Commercial Equipment Industriel Medical / Instrumentation

LAITON
RACCORD TUYAU
FERMÉE HORS TENSION

ELECTROVANNES PARKER LUCIFER®

Raccord	Orifice Ø	Facteur d'écoulement		Pression Différentielle		Temp. fluide		Joint	Electrovannes PARKER LUCIFER®			Puissance AC W	Groupe Electrique	N° schéma			
		Kv	Kvs	Min	Max	Min	Max		Ref. Valve	Ref. Bobine	Ref. Bobine						
3/8"	15	65	3.9	0	10	0	100	EPDM	22161303	2995	481885	8	2.0	3732			
									22161303	4270	481000	8	2.0	3732			
	1/2"	15	65	3.9	0	4	0	140	EPDM	22161303	4270	486285	14	4	2.0	3732	
										22161330	2995	481885	8	2.1	3732		
		15	65	3.9	4500	0	10	10	-10	120	FPM	22161330	-	482070	9	2.1	3732
												22161330	-	482190	11	9	2.1
1"	15	65	3.9	0	10	0	100	EPDM	22161303	2995	481885	8	2.0	3732			
									22161303	4270	481000	8	2.0	3732			
	15	80	4.8	0	10	0	100	EPDM	22161303	2995	481885	8	2.0	3444			
									22161303	4270	481000	8	2.0	3444			
		15	80	4.8	0	4	4	0	140	EPDM	22161303	4270	486285	14	4	2.0	3444
											22161703	2995	481885	8	2.0	3445	
15	80	4.8	0	10	0	120	EPDM	22161703	4270	481000	8	2.0	3445				
								22161703	4270	486285	14	4	2.0	3445			

Notes:
1. Tension continue uniquement (ou bobine avec pont redresseur)

ELECTROVANNES 2 VOIES

Dans cette page	Raccord de	Orifice (mm)	Kv (l/min)	Pression Diff. Max. (bar)	Temp. fluide (°C)	Temp. Amb. (°C)
de	3/8"	15	65	4	-10	-10
à	1"	15	80	10	140	50

481885 24 19.75 DIN 43650A 32 38 15 15 31.5 75 53

MEQHT : 0.640 kg

Schéma 3732

481885 24 19.75 DIN 43650A 32 38 15 15 31.5 75 53

Schéma 3444

481885 24 19.75 DIN 43650A 32 38 15 15 31.5 75 53

Schéma 3445

Informations pour les commandes

ISO

Un choix de groupes de bobines compatibles avec la vanne sélectionnée.

Schéma des dimensions 2D* et 3D

* Le schéma 2D correspond toujours à la bobine standard.

COMMENT CHOISIR UNE VANNE

Lorsque vous êtes dans la famille de produits **1** et l'application **2** choisies, le tableau vous aide à naviguer vers les produits qui répondent à vos critères.

Sélectionner d'abord le type de commande **3** ; puis déplacez-vous dans le tableau en sélectionnant le matériau du corps **4**, la fonction **5** et les exigences techniques **6**.

Lorsque vous avez trouvé des produits correspondant à vos critères, allez à la page indiquée dans la dernière colonne **7** pour trouver une sélection de produits correspondant à vos critères.

1 SÉLECTION DE LA FAMILLE DE PRODUITS

2 SÉLECTION DE L'APPLICATION

3 SÉLECTION DE LA COMMANDE

4 SÉLECTION DU CORPS

5 SÉLECTION DE LA FONCTION

6 SÉLECTION DES DONNÉES TECHNIQUES

7 SÉLECTION DE LA PAGE CORRESPONDANTE

1

ELECTROVANNES 2 VOIES



ELECTROVANNES POUR AIR SEC
OU LUBRIFIÉ, GAZ ET LIQUIDES
NEUTRES

2



2/2

Commande	Corps de Valve	Fonction	Raccord	Orifice (mm)	Facteur d'Écoulement Kv(l/min)	Pression Différentielle (bar)	Temp. Max. Fluide (°C)	Page Valves Parker	Page Valves Parker LUCIFER®	
Commande Directe	Laiton/Raccord tuyau	Fermée hors tension	1/8"	1,2 à 3	4,5	70	140	28	32	
			1/4"	1,2 à 6	13	100	140	30	32	
			3/8"	4 à 6	12	10	120	-	36	
		Ouverte hors tension	1/2"	8,5 à 11	36	4	120	-	36	
			1/8"	2,5	3,5	30	140	-	40	
	Laiton/Montage sur embase	Fermée hors tension	1/4"	1,5 à 3	4	40	140	38	40	
			1/4"	3 à 5	11	20	100	-	40	
			5 mm	1,5 à 3	4,5	100	130	-	42	
		Ouverte hors tension	5 mm	1,5	1,5	20	120	-	44	
			Attraction forcée	Fermée hors tension	3/8"	13 à 15	65	20	140	46
1/2"	13 à 15	65			20	140	46	48		
3/4"	15 à 20	100			20	140	46	50		
Ouverte hors tension	1"	15 à 25		170	20	140	46	52		
	3	4		5	1/4"	8 à 12	36	10	120	-
3/8"			11 à 13		50	10	120	54	54	
1/2"			11 à 15		60	10	120	54	54	
Ouverte hors tension			3/4"	15 à 20	135	40	120	54	64	
			1"	18 à 28	270	16	120	54	66	
6		7	Fermée hors tension	1 1/2"	40	425	16	120	-	66
				2"	40	540	16	120	-	66
				1/4"	8	36	40	140	-	70
			Ouverte hors tension	3/8"	11 à 13	50	40	140	68	70
				1/2"	13 à 15	60	40	140	68	70
		Commande par impulsion	3/4"	15 à 20	135	40	120	68	72	
			1"	25 à 40	420	16	120	68	72	
			1 1/4"	28	270	16	120	-	72	
			1 1/2"	40	420	12	100	-	72	
			2"	40	540	12	120	-	72	
Laiton/Montage sur embase	Fermée hors tension	1/4"	12	32	12	100	-	74		
		3/8"	12	45	12	100	-	74		
		1/2"	12	50	12	100	-	74		
	Ouverte hors tension	3/4"	18	100	12	100	-	74		
		1"	18	110	12	100	-	74		
14 mm	14	45	40	140	-	76				
14 mm	14	46	40	120	-	76				



COMMENT PASSER COMMANDE

AVEC DEUX GAMMES DE PRODUITS

7

SÉLECTION DE LA PA

Parker [Tableau bleu]

ELECTROVANNES
2 VOIES

2/2

ELECTROVANNES POUR AIR SEC OU LUBRIFIÉ,
GAZ ET LIQUIDES NEUTRES
COMMANDE DIRECTE

LAITON
RACCORD TUYAU
FERMÉE HORS TENSION



Raccord BSP	Orifice Ø	Facteur d'écoulement		Pression Différentielle		Temp. Fluide		Joint	Electrovannes PARKER			Puissance		Groupe Electrique	N° Schéma		
		Kv l/min	Kv m³/h	Min bar	Max bar	Min °C	Max °C		N° Commande Valve	Type de Valve	Type de Bobine	AC W	DC W				
1/8"	2.5	3.3	0.197	-	0	-	5	-10	140	FKM	363380	PM146FV	ZB12	-	12	20.1/20.2	034
	3	4.5	0.27	-	0	7	-	-10	140	FKM	363390	PM146HV	ZB09	9	-	20.1/20.2	034
	3	4.5	0.27	-	0	-	2	-10	140	FKM	363390	PM146HV	ZB12	-	12	20.1/20.2	034
1/4"	2.5	2.2	0.13	-	0	10	-	-10	140	FKM	398006	N74.4WV	WB4.5 230/50-60	4.5	-	1.3	065
	2.5	2.2	0.13	-	0	10	-	-10	140	FKM	398007	N74.4WV	WB4.5 230/50-60	4.5	-	1.3	065
	2.5	2.2	0.13	-	0	-	4	-10	140	FKM	398008	N74.4WV	WB5.0 230C	-	5	1.3	065
	2.5	2.2	0.13	-	0	-	4	-10	140	FKM	398010	N74.4WV	WB5.0 240C	-	5	1.3	065
	2.5	2.2	0.13	-	0	19	-	-10	140	FKM	398012	N74.4WV	WB8.0 230/50-60	8	-	1.3	065
	2.5	3.3	0.197	-	0	10	-	-10	140	FKM	363439	PM146WV	ZB09	9	-	20.1/20.2	034

- Les vannes et les bobines doivent être commandées séparément. (pour des exceptions, veuillez vérifier les notes de bas de page)
- Les vannes et les bobines sont livrées en tant qu'éléments séparés
- Pour les applications ATEX, sélectionnez des vannes de la gamme Parker Lucifer®

● **Vous devez commander :**
Vanne + Bobine

Commandez séparément

1

VANNE

Exemple de commande
d'une vanne :
363380

2

BOBINE

Exemple de commande
d'une bobine :
304002

Pour plus de détails,
référez-vous à la page 20 :

**Comment commander des
vannes Parker**

ATTENTION : pour les vannes des séries N74, N79, 131.4, 131, 175, 180 et 161, le numéro de commande de la vanne inclut la vanne assemblée et la bobine pour la tension indiquée.

GE CORRESPONDANTE

Parker Lucifer® [Tableau orange]

ELECTROVANNES
2 VOIES

2/2

ELECTROVANNES POUR AIR SEC OU LUBRIFIÉ,
GAZ ET LIQUIDES NEUTRES
COMMANDE DIRECTE

LAITON

RACCORD TUYAU

FERMÉE HORS TENSION



Raccord	Orifices Ø	Facteur d'écoulement			Pression Différentielle		Temp. Fluide		Joint	Electrovannes PARKER LUCIFER®			IS	Puissance		Groupe Electrique	N° Schéma
		Kv	Kv	Qn	Min	Max	Min	Max		Ref. Valve	Ref. Boîtier	Ref. Bobine		AC W	DC W		
BSP	4	7.5	0.45	480	0	10	4	-10	100	FKM	121K3206	2995	481865	8	9	2.0	3551
	4	7.5	0.45	480	0	10	5	-10	120	FKM	121K3206	4270	481000	8	8	2.0	3551
	4	7.5	0.45	480	0	10	10	-10	120	FKM	121K3206	4270	486265	14	14	2.0	3551
3/8"	5	11	0.66	750	0	7	2	-10	100	FKM	121K3106	2995	481865	8	9	2.0	3551
	5	11	0.66	750	0	7	2.8	-10	120	FKM	121K3106	4270	481000	8	8	2.0	3551
	5	11	0.66	750	0	7	5	-10	120	FKM	121K3106	4270	486265	14	14	2.0	3551
	6	12	0.72	1100	0	5	1.1	-10	100	FKM	121K3306	2995	481865	8	9	2.0/4.2	3551
	6	12	0.72	1100	0	5	1.5	-10	120	FKM	121K3306	4270	481000	8	8	2.0/4.2	3551
	6	12	0.72	1100	0	5	3	-10	120	FKM	121K3306	4270	486265	14	14	2.0/4.2	3551

- Disponible à partir d'une seule pièce
- Les vannes et bobines sont déjà assemblées lors de la livraison
- Disponible dans des configurations ATEX

- **Vous devez commander :**
Vanne + Boîtier + Bobine

Une seule commande

1

VANNE

2

BOÎTIER

3

BOBINE



Pour plus de détails,
référez-vous à la page 22 :
Comment commander des électrovannes Parker Lucifer®

Exemple de commande d'une vanne et d'une bobine :

1

121K3206

Référence de la vanne

2

2995

Boîtier

3

481865A2

Code bobine et tension

COMMENT COMMANDER DES VANNES PARKER

LES ÉLECTROVANNES PARKER SONT COMPOSÉES DE 2 ÉLÉMENTS :

la vanne ① et la bobine ②. Les deux éléments doivent être commandés séparément.

① Utiliser le numéro de commande de la vanne (6 chiffres) pour commander la vanne.

N° Commande Valve
363380
363390
363390

Exemple de n° de commande d'une vanne :
363380

Pour chaque vanne, plusieurs types de bobines sont proposés.

Pour plus de choix, la vanne sélectionnée est également compatible avec toutes les autres bobines du même groupe de bobines.

ELECTROVANNES 2 VOIES

2/2 ELECTROVANNES POUR AIR SEC OU LUBRIFIÉ, GAZ ET LIQUIDES NEUTRES
COMMANDE DIRECTE

LAITON
RACCORD TUYAU
FERMÉE HORS TENSION

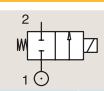

Raccord	Orifice Ø	Facteur d'Écoulement			Pression Différentielle		Temp. Fluide		Joint	Electrovannes PARKER			Puissance		Groupe Electrique	N° Schéma	
		Kv	Qn	Qn	Min	Max	Min	Max		N° Commande Valve	Type de Valve	Type de Bobine	AC W	DC W			
1/8"	2.5	3.3	0.197	-	0	7	-	-10	140	FKM	363380	PM146FV	ZB12	-	12	20.1/20.2	034
	3	4.5	0.27	-	0	7	-	-10	140	FKM	363390	PM146HV	ZB09	9	-	20.1/20.2	034
	3	4.5	0.27	-	0	2	-	-10	140	FKM	363390	PM146HV	ZB12	-	12	20.1/20.2	034
	2.5	2.2	0.13	-	0	10	-	-10	140	FKM	398006	N74.4VV	WB4.5 230V-60	4.5	-	1.3	065
	2.5	2.2	0.13	-	0	10	-	-10	140	FKM	398007	N74.4VV	WB4.5 245V-60	4.5	-	1.3	065
	2.5	2.2	0.13	-	0	4	-	-10	140	FKM	398008	N74.4VV	WB5.0 120C	5	-	1.3	065
1/4"	2.5	2.2	0.13	-	0	10	-	-10	140	FKM	398010	N74.4VV	WB5.0 240C	5	-	1.3	065
	2.5	2.2	0.13	-	0	19	-	-10	140	FKM	398012	N74.4VV	WB8.0 230V-60	8	-	1.3	065
	2.5	3.3	0.197	-	0	10	-	-10	140	FKM	363439	PM146WV	ZB09	9	-	20.1/20.2	035
	2.5	3.3	0.197	-	0	10	-	-10	140	FKM	363439	PM146WV	ZB12	-	12	20.1/20.2	035
	3	4.5	0.27	-	0	7	-	-10	140	FKM	363444	PM146YV	ZB09	9	-	20.1/20.2	035
	3	4.5	0.27	-	0	4	-	-10	140	FKM	363444	PM146YV	ZB12	-	12	20.1/20.2	035
	4.5	9	0.527	-	0	6	-	-10	140	FKM	363457	PM146.3KV	ZB14	14	-	20.2	035
	4.5	9	0.527	-	0	2.5	-	-10	140	FKM	363457	PM146.3KV	ZB16	-	16	20.2	035
	6	13	0.75	-	0	6	-	-10	140	FKM	363467	PM146.3ABV	ZB14	14	-	20.2	035
	6	13	0.75	-	0	1	-	-10	140	FKM	363467	PM146.3ABV	ZB16	-	16	20.2	035

Notes:
1. La référence "N° de Commande" désigne valve + bobine à la tension indiquée dans la colonne type de bobine.



30

Parker Hannifin Corporation
Fluid Control Division Europe
Catalogue Général FCDE/0110/FR/V1.1

LES BOBINES PARKER DOIVENT ÊTRE COMMANDÉES SÉPARÉMENT

2 Utiliser le numéro de commande de la bobine (6 chiffres) pour commander les bobines

Sélectionnez la bobine et utilisez le numéro de commande à 6 chiffres pour passer votre commande.

V CA/Hz	Numéro de commande
ZB09 24/50-60	304004
ZB09 12/50-60	304002

Exemple de n° de commande d'une bobine :
304002

Important :

Les vannes sont livrées unitairement ou par boîtes de lots.

BOBINES

20.1 BOBINES POUR CONNECTEUR À BROCHES DIN

RoHS CE UL

BOBINE DE LA SÉRIE ZB

Ces bobines peuvent être montées avec toutes les électrovannes Parker correspondant au groupe électrique spécifique. Voir la colonne « Groupe électrique » sur les pages concernant les vannes. Bobine fabriquée avec du fil de cuivre de classe H, moulée dans du polyester à base de matériaux thermoplastiques avec 30 % de fibre de verre. Indice de protection IP65 conforme à EN 175301-803:2006-A. Connecteur à 3 broches.



Cette bobine est conforme aux normes de sécurité CEI/CENELEC ainsi qu'à la directive européenne Basse tension.

Pour la version homologuée UL : fichier UL n° MH19410. Connecteur à broches DIN à commander séparément (voir la section des accessoires de la bobine).

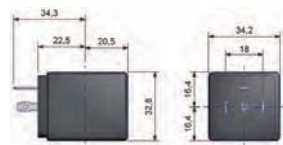

Caractéristiques	Standard	Version homologuée UL																																																												
Référence (sans broche DIN)	ZB09/ZB12	ZB09 pour CA uniquement																																																												
Groupe électrique	20.1																																																													
Indice de protection	IP65 selon les normes CEI/EN 60529 (avec broche DIN et joint d'étanchéité)																																																													
Indice d'isolation	F 155 °C																																																													
Raccordement électrique	La bobine est raccordée à l'aide d'une broche 2 P + T selon EN 175301-803 - A																																																													
Température ambiante	entre -10 °C et +50 °C L'application est également limitée par la plage de température de la vanne.																																																													
Alimen- tation électrique	CC P (roid) 20 °C	12 W																																																												
	CA P (roid) 20 °C	9 W																																																												
	CA Attraction (roid)	25 VA																																																												
Poids	130 g																																																													
Tensions « Un »	<table border="1"> <thead> <tr> <th>V CA/Hz</th> <th>Numéro de commande</th> <th>V CC</th> <th>Numéro de commande</th> <th>V CA/Hz</th> <th>Numéro de commande</th> </tr> </thead> <tbody> <tr> <td>ZB09 24/50-60</td> <td>304004</td> <td>ZB12 12 CC</td> <td>304018</td> <td>ZB09 24/60</td> <td>304048</td> </tr> <tr> <td>ZB09 12/50-60</td> <td>304002</td> <td>ZB12 24 CC</td> <td>304020</td> <td>ZB09 110-120/60</td> <td>304011</td> </tr> <tr> <td>ZB09 230/50-60</td> <td>304012</td> <td>ZB12 110 CC</td> <td>304022</td> <td>ZB09 208-240/60</td> <td>304051</td> </tr> <tr> <td>ZB09 115/50-60</td> <td>304010</td> <td>ZB12 48 V CC</td> <td>304021</td> <td></td> <td></td> </tr> <tr> <td>ZB09 100/50-60</td> <td>304009</td> <td></td> <td></td> <td></td> <td></td> </tr> <tr> <td>ZB09 240/50-60</td> <td>304014</td> <td></td> <td></td> <td></td> <td></td> </tr> <tr> <td>ZB09 48/50-60</td> <td>304008</td> <td></td> <td></td> <td></td> <td></td> </tr> <tr> <td>ZB09 110-120/60</td> <td>304011</td> <td></td> <td></td> <td></td> <td></td> </tr> <tr> <td>ZB09 380/50-60</td> <td>304016</td> <td></td> <td></td> <td></td> <td></td> </tr> </tbody> </table>	V CA/Hz	Numéro de commande	V CC	Numéro de commande	V CA/Hz	Numéro de commande	ZB09 24/50-60	304004	ZB12 12 CC	304018	ZB09 24/60	304048	ZB09 12/50-60	304002	ZB12 24 CC	304020	ZB09 110-120/60	304011	ZB09 230/50-60	304012	ZB12 110 CC	304022	ZB09 208-240/60	304051	ZB09 115/50-60	304010	ZB12 48 V CC	304021			ZB09 100/50-60	304009					ZB09 240/50-60	304014					ZB09 48/50-60	304008					ZB09 110-120/60	304011					ZB09 380/50-60	304016					
V CA/Hz	Numéro de commande	V CC	Numéro de commande	V CA/Hz	Numéro de commande																																																									
ZB09 24/50-60	304004	ZB12 12 CC	304018	ZB09 24/60	304048																																																									
ZB09 12/50-60	304002	ZB12 24 CC	304020	ZB09 110-120/60	304011																																																									
ZB09 230/50-60	304012	ZB12 110 CC	304022	ZB09 208-240/60	304051																																																									
ZB09 115/50-60	304010	ZB12 48 V CC	304021																																																											
ZB09 100/50-60	304009																																																													
ZB09 240/50-60	304014																																																													
ZB09 48/50-60	304008																																																													
ZB09 110-120/60	304011																																																													
ZB09 380/50-60	304016																																																													

Pour commander une bobine : utilisez le numéro de commande à 6 chiffres - Exemple de code : ZB09 24/50-60 = **304004**
D'autres tensions possibles se trouvent dans le tableau des codes tension à la fin de la section des bobines.

468

Parker Hannifin Corporation
Fluid Control Division Europe
Catalogue général FCDE/0110/FR/V1.1

Section des bobines à la fin du catalogue

ATTENTION : Pour les applications ATEX, veuillez vous reporter aux vannes Parker Lucifer®.

21

Parker Hannifin Corporation
Fluid Control Division Europe
Catalogue général FCDE/0110/FR/V1.1

COMMENT COMMANDER DES ÉLECTROVANNES PARKER LUCIFER®

LES ÉLECTROVANNES PARKER LUCIFER® SONT COMPOSÉES DE 3 ÉLÉMENTS :

La vanne ① + le boîtier ② + la bobine ③.

1. Sélectionnez la référence de la vanne
2. Sélectionnez le boîtier
3. Sélectionnez la bobine

① Choisissez la référence de la vanne.

Ref.
Valve

121K3206

121K3206

121K3206

② Sélectionnez le boîtier en fonction du niveau de protection (IP 44 à IP 67 selon la section des bobines)

Ref.
Boîtier

2995

4270

4270

Pour chaque vanne, plusieurs types de bobines sont proposés.

ELECTROVANNES
2 VOIES

2/2

ELECTROVANNES POUR AIR SEC OU LUBRIFIÉ,
GAZ ET LIQUIDES NEUTRES
COMMANDE DIRECTE

LAITON
RACCORD TUYAU
FERMÉE HORS TENSION



Raccord	Orifice Ø	Facteur d'Écoulement			Pression Différentielle		Temp. Fluide		Joint	Electrovannes PARKER LUCIFER®			IS	Puissance		Groupe Electrique	N° Schéma
		Kv	KV	Qn	Min	Max	Min	Max		Ref. Valve	Ref. Boîtier	Ref. Bobine		AC W	DC W		
3/8"	4	7.5	0.45	480	0	10	4	-10	100	FKM	121K3206	2995	481865	8	9	2.0	3551
	4	7.5	0.45	480	0	10	5	-10	120	FKM	121K3206	4270	481000	8	8	2.0	3551
	5	11	0.66	750	0	10	10	-10	120	FKM	121K3206	4270	486265	14	14	2.0	3551
	5	11	0.66	750	0	7	2	-10	100	FKM	121K3106	2995	481865	8	9	2.0	3551
	5	11	0.66	750	0	7	2	-10	120	FKM	121K3106	4270	481000	8	8	2.0	3551
	5	11	0.66	750	0	7	5	-10	120	FKM	121K3106	4270	486265	14	14	2.0	3551
1/2"	6	12	0.72	1100	0	5	1.1	-10	100	FKM	121K3306	2995	481865	8	9	2.0/14.2	3551
	6	12	0.72	1100	0	5	1.5	-10	120	FKM	121K3306	4270	481000	8	8	2.0/14.2	3551
	6	12	0.72	1100	0	5	3	-10	120	FKM	121K3306	4270	486265	14	14	2.0/14.2	3551
	8.5	25	1.5	1600	0	1.1	0.5	-10	100	FKM	E121K46	2995	481865	8	9	2.0	3427
	8.5	25	1.5	1600	0	2.2	0.5	-10	120	FKM	E121K46	4270	481000	8	8	2.0	3427
	8.5	25	1.5	1600	0	4	1.2	-10	120	FKM	E121K46	4270	486265	14	14	2.0	3427
1/2"	11	36	2.16	2500	0	0.7	0.3	-10	100	FKM	E121K45	2995	481865	8	9	2.0	3427
	11	36	2.16	2500	0	1.2	0.35	-10	120	FKM	E121K45	4270	481000	8	8	2.0	3427
	11	36	2.16	2500	0	2.5	0.7	-10	120	FKM	E121K45	4270	486265	14	14	2.0	3427

Parker

36

Parker Hannifin Corporation
Fluid Control Division Europe
Catalogue Général FCDE/0110/FRV1.1

Pour plus de choix, la vanne sélectionnée est également compatible avec toutes les autres bobines du même groupe de bobines.

Les bobines Parker Lucifer® sont disponibles avec beaucoup de tensions différentes. Choisissez la tension qu'il vous faut en ajoutant le code tension à la fin de votre numéro de commande.

3 Choisissez la bobine et le code tension.

Réf. bobine

481865

Code tension

V CA/Hz

Code

24/50
48/50
110/50

A2
A4
A5

Exemple de commande d'une vanne et d'une bobine :

① - ② - ③

121K3206 - 2995 - 481865A2

Référence de la vanne

Boîtier

Code bobine et tension

BOBINES

GRUPE ÉLECTRIQUE

2.0/2.1 BOBINES POUR CONNECTEUR À BROCHES DIN

RoHS CE D'E

BOBINES 32 mm

Ces bobines peuvent être montées avec toutes les électrovannes Parker correspondant au groupe électrique spécifique.
Voir la colonne « Groupe électrique » sur les pages concernant les vannes.
Ensemble enrobé comprenant une bobine, un circuit magnétique et une broche enfichable.
Le matériau synthétique enrobé permet de protéger l'ensemble compact contre la pénétration de corps étrangers (ex. : poussières, huile, eau, etc).
Montage facile dans les espaces confinés - Protection contre les chocs et la corrosion - Simplification du passage aux nouvelles exigences de l'équipement existant, etc.
Les bobines sont conformes aux normes de sécurité CEI/CENELEC ainsi qu'à la directive européenne Basse tension.



Caractéristiques	Standard	Double fréquence
Réf. (sans broche DIN)	481865	483510
Réf. (avec broche DIN)	482725	482635
Groupe électrique	2.0/2.1	
Indice de protection	IP65 selon les normes CEI/EN 60529 (avec broche DIN).	
Classe d'isolation	F 155 °C	
Raccordement électrique	La bobine est raccordée à l'aide d'une broche 2 P + T selon EN 175301-803, type A.	
Température ambiante	entre -40 °C et +50 °C L'application est également limitée par la plage de température de la vanne.	
Alimentation électrique	CC	9 W
	P (froid) 40 °C	12 W
	CA	8 W
Attraction (froid)	26 VA (9 W)	32 VA (10 W)
Poids	130 g (sans broche)	

Tensions « Un »	V CA/Hz	Code	V CC	Code	V CA/Hz	Code
entre -10 % et +10 % de Un	24/50	A2	24	C2	24/50, 24/60	P0
	48/50	A4	48	C4	48/50, 48/60	S4
	110/50	A5	110	C5	110/115/50, 120/60	S5
	220-230/50	30			220-240/50, 240/60	S6

Pour commander une bobine, choisissez la réf. bobine + le code tension, par exemple : 481865 pour 24 V CC = **481865C2**
D'autres tensions possibles se trouvent dans le tableau des codes tension à la fin de la section des bobines.

Ces bobines doivent être utilisées avec les boîtiers adaptés. Voir les exemples ci-dessous :



Le kit d'assemblage de la bobine avec la réf. 2995 correspond au « boîtier » du système de numérotation des vannes Lucifer® (vanne - boîtier - bobine - tension).
Il est composé d'une plaque signalétique avec des informations concernant le type de vanne, d'une rondelle et d'un écrou pour assurer la fixation entre la bobine de 32 mm et la vanne.



Parker Hannifin Corporation
Fluid Control Division Europe
Catalogue général FCDE/0110/FR/V1.1

Important :

Les valves, boîtiers et bobines peuvent être commandés séparément comme pièces de remplacement.

COMMENT UTILISER LES GROUPES ELECTRIQUES

SUR UNE PAGE DE VANNES

L'un des points forts de Parker est la modularité, l'adaptabilité et la flexibilité de nos produits. Lorsque vous sélectionnez une électrovanne, les bobines affichées dans le tableau ont été choisies parce qu'elles répondent aux exigences de la plupart des applications.

Electrovannes PARKER LUCIFER®		
Ref. Valve	Ref. Boîtier	Ref. Bobine
121K3206	2995	481865
121K3206	4270	481000
121K3206	4270	486265

Cependant, dans certains cas, vous aurez besoin d'une caractéristique spécifique et serez donc amené à choisir une autre bobine.

Nous avons créé des groupes pour faciliter la sélection d'une bobine compatible avec la vanne sélectionnée.

Groupe Electrique
2.0
2.0
2.0

Exemple :

La vanne 121K3206 est proposée avec la bobine 481865 mais vous pouvez aussi sélectionner n'importe quelle autre bobine du groupe 2.0.

ELECTROVANNES 2 VOIES

2/2

ELECTROVANNES POUR AIR SEC OU LUBRIFIÉ,
GAZ ET LIQUIDES NEUTRES
COMMANDE DIRECTE

LAITON
RACCORD TUYAU
FERMÉE HORS TENSION



Raccord	Orifice Ø	Facteur d'Écoulement			Pression Différentielle		Temp. Fluide		Joint	Electrovannes PARKER LUCIFER®			IS	Puissance		Groupe Electrique	N° Schéma
		Kv	Kv	Q ₁	Min	Max	Min	Max		Ref. Valve	Ref. Boîtier	Ref. Bobine		AC W	DC W		
BSP	4	7.5	0.45	480	0	10	4	-10	100	FKM	121K3206	2995	481865	8	9	2.0	3551
	4	7.5	0.45	480	0	10	4	-10	120	FKM	121K3206	4270	481000	8	8	2.0	3551
	4	7.5	0.45	480	0	10	10	-10	120	FKM	121K3206	4270	486265	14	14	2.0	3551
	5	11	0.66	750	0	7	2	-10	100	FKM	121K3106	2995	481865	8	9	2.0	3551
	5	11	0.66	750	0	7	2.8	-10	120	FKM	121K3106	4270	481000	8	8	2.0	3551
	5	11	0.66	750	0	7	5	-10	120	FKM	121K3106	4270	486265	14	14	2.0	3551
3/8"	6	12	0.72	1100	0	5	1.1	-10	100	FKM	121K3306	2995	481865	8	9	2.0/14.2	3551
	6	12	0.72	1100	0	5	1.5	-10	120	FKM	121K3306	4270	481000	8	8	2.0/14.2	3551
	6	12	0.72	1100	0	5	3	-10	120	FKM	121K3306	4270	486265	14	14	2.0/14.2	3551
	8.5	25	1.5	1600	0	1.1	0.5	-10	100	FKM	E121K46	2995	481865	8	9	2.0	3427
	8.5	25	1.5	1600	0	2.2	0.5	-10	120	FKM	E121K46	4270	481000	8	8	2.0	3427
	8.5	25	1.5	1600	0	4	1.2	-10	120	FKM	E121K46	4270	486265	14	14	2.0	3427
1/2"	11	36	2.16	2500	0	0.7	0.3	-10	100	FKM	E121K45	2995	481865	8	9	2.0	3427
	11	36	2.16	2500	0	1.2	0.35	-10	120	FKM	E121K45	4270	481000	8	8	2.0	3427
	11	36	2.16	2500	0	2.5	0.7	-10	120	FKM	E121K45	4270	486265	14	14	2.0	3427
	11	36	2.16	2500	0	2.5	0.7	-10	120	FKM	E121K45	4270	486265	14	14	2.0	3427



36

Parker Hannifin Corporation
 Fluid Control Division Europe
 Catalogue Général FCDE/0110/FR/V1.1

Il est également possible de choisir d'abord la bobine et de sélectionner ensuite la vanne en utilisant les groupes de bobines.

COMMENT UTILISER LES GROUPES ELECTRIQUES

SUR UNE PAGE DE BOBINES

La section des bobines se trouve à la fin du catalogue et indique les caractéristiques de chaque bobine, avec son numéro de référence, la classe d'isolation, la température ambiante, l'alimentation électrique et le poids.

2.0/2.1

Comme indiqué précédemment, la vanne 121K3206 est proposée avec la bobine 481865 mais elle est aussi compatible avec le groupe de bobines 2.0. Cela signifie que la bobine 482725 est également compatible avec la vanne sélectionnée puisqu'elle fait partie du même groupe.

Dans la section des bobines vous trouvez pour chaque bobine le groupe auquel elle appartient. Ceci vous permet de découvrir toutes les autres bobines compatibles avec la vanne sélectionnée.

BOBINES



2.0/2.1
BOBINES POUR CONNECTEUR À BROCHES DIN

BOBINES 32 mm

Ces bobines peuvent être montées avec toutes les électrovannes Parker correspondant au groupe électrique spécifique. Voir la colonne « Groupe électrique » sur les pages concernant les vannes.

Ensemble enrobé comprenant une bobine, un circuit magnétique et une broche enfichable.

Le matériau synthétique enrobé permet de protéger l'ensemble compact contre la pénétration de corps étrangers (eau, poussières, huile, eau, etc).

Montage facile dans les espaces confinés - Protection contre les chocs et la corrosion - Simplification du passage aux nouvelles exigences de l'équipement existant, etc.

Les bobines sont conformes aux normes de sécurité CEI/CENELEC ainsi qu'à la directive européenne Basse tension.



Caractéristiques	Standard	Double fréquence															
Réf. (sans broche DIN)	481865	483510															
Réf. (avec broche DIN)	482725	482635															
Groupe électrique	2.0/2.1																
Indice de protection	IP65 selon les normes CEI/EN 60529 (avec broche DIN).																
Classe d'isolation	F 155 °C																
Raccordement électrique	La bobine est raccordée à l'aide d'une broche 2 P + T selon EN 175301-803, type A.																
Température ambiante	entre -40 °C et +50 °C L'application est également limitée par la plage de température de la vanne.																
Alimentation électrique	CC Pn (chaud)	9 W															
	P (froid) 20 °C	12 W															
	Pn (maintien)	8 W															
	CA Attraction (froid)	26 VA (9 W)															
Poids	130 g (sans broche)																
Tensions « Un »	<table border="1" style="width: 100%; border-collapse: collapse;"> <thead> <tr style="background-color: #ffcc00;"> <th>V CA/Hz</th> <th>Code</th> <th>V CC</th> <th>Code</th> <th>V CA/Hz</th> <th>Code</th> </tr> </thead> <tbody> <tr> <td>entre -10 % et +10 % de Un</td> <td>24/50 A2</td> <td>24 C2</td> <td>24/50, 24/60 P0</td> <td>48/50, 48/60 S4</td> <td>110/50 AS</td> <td>110 C5</td> <td>110/115/50, 120/60 S5</td> <td>220-240/50, 240/60 S6</td> </tr> </tbody> </table>		V CA/Hz	Code	V CC	Code	V CA/Hz	Code	entre -10 % et +10 % de Un	24/50 A2	24 C2	24/50, 24/60 P0	48/50, 48/60 S4	110/50 AS	110 C5	110/115/50, 120/60 S5	220-240/50, 240/60 S6
V CA/Hz	Code	V CC	Code	V CA/Hz	Code												
entre -10 % et +10 % de Un	24/50 A2	24 C2	24/50, 24/60 P0	48/50, 48/60 S4	110/50 AS	110 C5	110/115/50, 120/60 S5	220-240/50, 240/60 S6									

Pour commander une bobine, choisissez la réf. bobine + le code tension, par exemple : 481865 pour 24 V CC = **481865C2**
D'autres tensions possibles se trouvent dans le tableau des codes tension à la fin de la section des bobines.

Ces bobines doivent être utilisées avec les boîtiers adaptés. Voir les exemples ci-dessous :

Le kit d'assemblage de la bobine avec la réf. **2995** correspond au « boîtier » du système de numérotation des vannes Lucifer® (vanne - boîtier - bobine - tension).

Il est composé d'une plaque signalétique avec des informations concernant le type de vanne, d'une rondelle et d'un écrou pour assurer la fixation entre la bobine de 32 mm et la vanne.

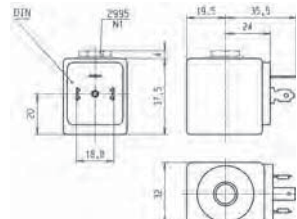

454

Parker Hannifin Corporation
 Fluid Control Division Europe
 Catalogue général FCDE/0110/FR/V1.1



ELECTROVANNES POUR AIR SEC OU LUBRIFIÉ, GAZ ET LIQUIDES NEUTRES



Huile



Eau



Air

2/2

Commande	Corps de Valve	Fonction	Raccord	Orifice (mm)	Facteur d'Écoulement Kv(l/min)	Pression Différentielle (bar)	Temp. Max. Fluide (°C)	Page Valves Parker	Page Valves Parker LUCIFER®		
Commande Directe	Laiton/Raccord tuyau	Fermée hors tension	1/8"	1.2 à 3	4.5	70	140	28	32		
			1/4"	1.2 à 6	13	100	140	30	32		
			3/8"	4 à 6	12	10	120	-	36		
			1/2"	8.5 à 11	36	4	120	-	36		
		Ouvverte hors tension	1/8"	2.5	3.5	30	140	-	40		
			1/4"	1.5 à 3	4	40	140	38	40		
			Commande par impulsion		1/4"	3 à 5	11	20	100	-	40
			Laiton/Montage sur embase	Fermée hors tension	5 mm	1.5 à 3	4.5	100	130	-	42
Ouvverte hors tension	5 mm	1.5		1.5	20	120	-	44			
Attraction forcée	Laiton/Raccord tuyau	Fermée hors tension	3/8"	13 à 15	65	20	140	46	48		
			1/2"	13 à 15	65	20	140	46	48		
			3/4"	15 à 20	100	20	140	46	50		
			1"	15 à 25	170	20	140	46	52		
			1"	15 à 25	170	20	140	46	52		
Servo-commande	Laiton/Raccord tuyau	Fermée hors tension	1/4"	8 à 12	36	40	120	-	56		
			3/8"	11 à 13	50	40	120	54	58		
			1/2"	11 à 15	60	40	120	54	60		
			3/4"	15 à 20	135	40	120	54	62		
			1"	18 à 28	270	16	120	54	64		
			1 1/2"	40	425	16	120	-	66		
			2"	40	540	16	120	-	66		
			Ouvverte hors tension	1/4"	8	36	40	140	-	70	
				3/8"	11 à 13	50	40	140	68	70	
				1/2"	13 à 15	60	40	140	68	70	
		3/4"		15 à 20	135	40	120	68	72		
		1"		25 à 40	420	16	120	68	72		
		1 1/4"		28	270	16	120	-	72		
		1 1/2"		40	420	12	100	-	72		
		2"		40	540	12	120	-	72		
		Commande par impulsion		1/4"	12	32	12	100	-	74	
				3/8"	12	45	12	100	-	74	
			1/2"	12	50	12	100	-	74		
			3/4"	18	100	12	100	-	74		
			1"	18	110	12	100	-	74		
Laiton/Montage sur embase	Fermée hors tension		14 mm	14	45	40	140	-	76		
	Ouvverte hors tension	14 mm	14	46	40	120	-	76			

2/2

ELECTROVANNES POUR AIR SEC OU LUBRIFIÉ, GAZ ET LIQUIDES NEUTRES COMMANDE DIRECTE



Equipement Commercial



Equipement Industriel



Systèmes de Chauffage

LAITON RACCORD TUYAU

FERMÉE HORS TENSION

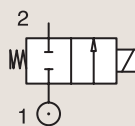

Raccord BSP	Orifice Ø mm	Facteur d'Écoulement			Pression Différentielle			Temp. Fluide		Joint	Electrovannes PARKER			Puissance		Groupe Electrique	N° Schéma
		Kv l/min	KV m³/h	Qn m³/h	Min bar	Max AC bar	DC bar	Min °C	Max °C		N° Commande Valve	Type de Valve	Type de Bobine	AC W	DC W		
1/8"	1.2	0.7	0.04	-	0	20	-	-10	140	FKM	398018 ₁	N74.4IV	WB4.5 115/50-60	4.5	-	1.3	064
	1.5	1	0.06	-	0	20	-	-10	140	FKM	398017 ₁	N74.4AV	WB4.5 115/50-60	4.5	-	1.3	064
	1.5	1	0.06	-	0	20	-	-10	140	FKM	398014 ₁	N74.4AV	WB4.5 230/50-60	4.5	-	1.3	064
	1.5	1	0.06	-	0	20	-	-10	140	FKM	398030 ₁	N74.4AV	WB4.5 24/50-60	4.5	-	1.3	064
	1.5	1	0.06	-	0	-	10	-10	140	FKM	398034 ₁	N74.4AV	WB5.0 12DC	-	5	1.3	064
	1.5	1	0.06	-	0	-	10	-10	140	FKM	398016 ₁	N74.4AV	WB5.0 24DC	-	5	1.3	064
	1.5	1	0.06	-	0	-	10	-10	140	FKM	398013 ₁	N74.4AVA.5	WB5.0 5.0 24DC	-	5	1.3	064
	1.5	1.5	0.09	-	0	20	-	-10	140	FKM	363378	PM146BV	ZB09	9	-	20.1/20.2	034
	1.5	1.5	0.09	-	0	-	18	-10	140	FKM	363378	PM146BV	ZB12	-	12	20.1/20.2	034
	2	1.5	0.09	-	0	15	-	-10	140	FKM	398050 ₁	N74.4BV	WB4.5 115/50-60	4.5	-	1.3	064
	2	1.5	0.09	-	0	15	-	-10	140	FKM	398042U ₁	N74.4BV	WB4.5 115/60	4.5	-	1.3	064
	2	1.5	0.09	-	0	15	-	-10	140	FKM	398046U ₁	N74.4BV	WB4.5 208-240/60	4.5	-	1.3	064
	2	1.5	0.09	-	0	15	-	-10	140	FKM	398038 ₁	N74.4BV	WB4.5 230/50-60	4.5	-	1.3	064
	2	1.5	0.09	-	0	15	-	-10	140	FKM	398048 ₁	N74.4BV	WB4.5 24/50-60	4.5	-	1.3	064
	2	1.5	0.09	-	0	-	7	-10	140	FKM	398029 ₁	N74.4BV	WB5.0 12DC	-	5	1.3	064
	2	1.5	0.09	-	0	-	7	-10	140	FKM	398028 ₁	N74.4BV	WB5.0 24DC	-	5	1.3	064
	2.5	2.2	0.13	-	0	10	-	-10	140	FKM	398026 ₁	N74.4FV	WB4.5 115/50-60	4.5	-	1.3	064
	2.5	2.2	0.13	-	0	10	-	-10	140	FKM	398003 ₁	N74.4FV	WB4.5 115/60	4.5	-	1.3	064
	2.5	2.2	0.13	-	0	10	-	-10	140	FKM	398000 ₁	N74.4FV	WB4.5 230/50-60	4.5	-	1.3	064
	2.5	2.2	0.13	-	0	10	-	-10	140	FKM	398024 ₁	N74.4FV	WB4.5 24/50-60	4.5	-	1.3	064
2.5	2.2	0.13	-	0	10	-	-10	140	FKM	398001 ₁	N74.4FV	WB4.5 240/50-60	4.5	-	1.3	064	
2.5	2.2	0.13	-	0	-	4	-10	140	FKM	398052 ₁	N74.4FV	WB5.0 12DC	-	5	1.3	064	
2.5	2.2	0.13	-	0	-	4	-10	140	FKM	398022 ₁	N74.4FV	WB5.0 24DC	-	5	1.3	064	
2.5	3.3	0.197	-	0	10	-	-10	140	FKM	363380	PM146FV	ZB09	9	-	20.1/20.2	034	

Notes:

1.La référence "N° de Commande" désigne valve + bobine à la tension indiquée dans la colonne type de bobine



Dans cette page	Raccord	Orifice (mm)	Kv (l/min)	Pression Diff. Max. (bar)	Temp. Fluide (°C)	Temp. Amb. (°C)
de	1/8"	1.2	0.7	4	-10	-10
à	1/8"	2.5	3.3	20	140	50



Schéma 064



Schéma 034

2/2

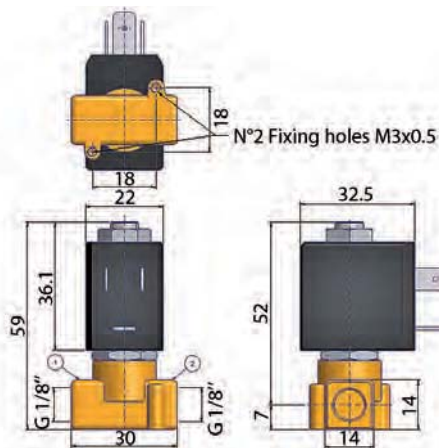
ELECTROVANNES POUR AIR SEC OU LUBRIFIÉ, GAZ ET LIQUIDES NEUTRES COMMANDE DIRECTE

LAITON

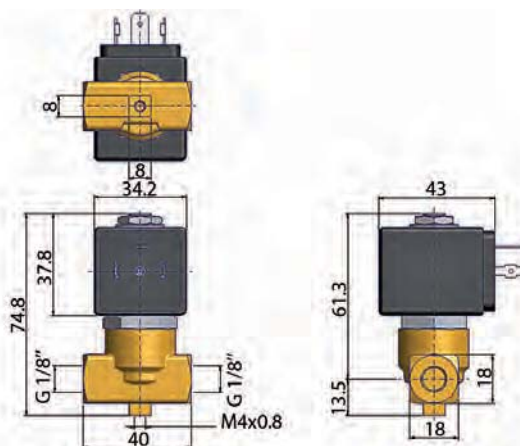
RACCORD TUYAU

FERMÉE HORS TENSION

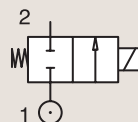

Raccord BSP	Orifice Ø mm	Facteur d'Écoulement			Pression Différentielle			Temp. Fluide		Joint	Electrovannes PARKER			Puissance		Groupe Electrique	N° Schéma
		Kv l/min	KV m³/h	Qn m³/h	Min bar	Max		Min °C	Max °C		N° Commande Valve	Type de Valve	Type de Bobine	AC W	DC W		
						AC bar	DC bar										
1/8"	2.5	3.3	0.197	-	0	-	5	-10	140	FKM	363380	PM146FV	ZB12	-	12	20.1/20.2	034
	3	4.5	0.27	-	0	7	-	-10	140	FKM	363390	PM146HV	ZB09	9	-	20.1/20.2	034
	3	4.5	0.27	-	0	-	2	-10	140	FKM	363390	PM146HV	ZB12	-	12	20.1/20.2	034
1/4"	2.5	2.2	0.13	-	0	10	-	-10	140	FKM	398006 ₁	N74.4WV	WB4.5 230/50-60	4.5	-	1.3	065
	2.5	2.2	0.13	-	0	10	-	-10	140	FKM	398007 ₁	N74.4WV	WB4.5 24/50-60	4.5	-	1.3	065
	2.5	2.2	0.13	-	0	-	4	-10	140	FKM	398008 ₁	N74.4WV	WB5.0 12DC	-	5	1.3	065
	2.5	2.2	0.13	-	0	-	4	-10	140	FKM	398010 ₁	N74.4WV	WB5.0 24DC	-	5	1.3	065
	2.5	2.2	0.13	-	0	19	-	-10	140	FKM	398012 ₁	N74.4WV	WB8.0 230/50-60	8	-	1.3	065
	2.5	3.3	0.197	-	0	10	-	-10	140	FKM	363435	PM146WV	ZB09	9	-	20.1/20.2	035
	2.5	3.3	0.197	-	0	-	10	-10	140	FKM	363435	PM146WV	ZB12	-	12	20.1/20.2	035
	3	4.5	0.27	-	0	7	-	-10	140	FKM	363444	PM146YV	ZB09	9	-	20.1/20.2	035
	3	4.5	0.27	-	0	-	4	-10	140	FKM	363444	PM146YV	ZB12	-	12	20.1/20.2	035
	4.5	9	0.527	-	0	6	-	-10	140	FKM	363457	PM146.3KV	ZB14	14	-	20.2	035
	4.5	9	0.527	-	0	-	2.5	-10	140	FKM	363457	PM146.3KV	ZB16	-	16	20.2	035
	6	13	0.75	-	0	6	-	-10	140	FKM	363467	PM146.3ABV	ZB14	14	-	20.2	035
6	13	0.75	-	0	-	1	-10	140	FKM	363467	PM146.3ABV	ZB16	-	16	20.2	035	

Notes:

1.La reference "N° de Commande" designe valve + bobine à la tension indiquée dans la colonne type de bobine



Dans cette page	Raccord	Orifice (mm)	Kv (l/min)	Pression Diff. Max. (bar)	Temp. Fluide (°C)	Temp. Amb. (°C)
de	1/8"	2.5	2.2	1	-10	-10
à	1/4"	6	13	19	140	50



Schéma 034



Schéma 065

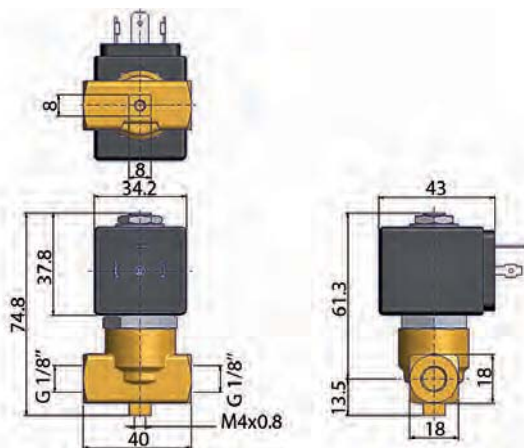

Schéma 035

2/2

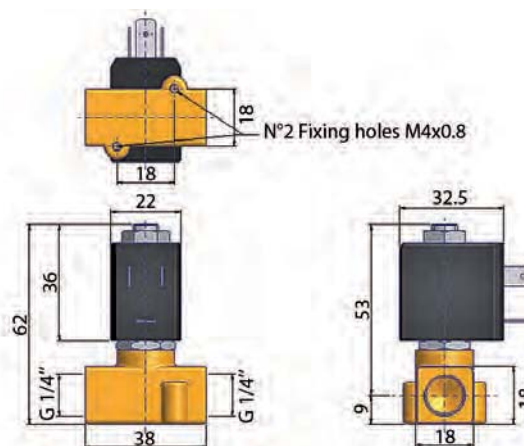
ELECTROVANNES POUR AIR SEC OU LUBRIFIÉ, GAZ ET LIQUIDES NEUTRES COMMANDE DIRECTE

LAITON

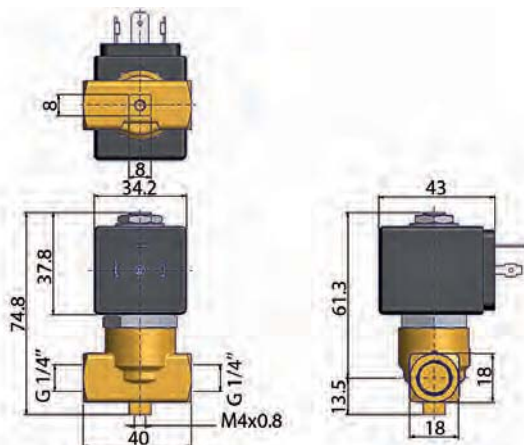
RACCORD TUYAU

FERMÉE HORS TENSION

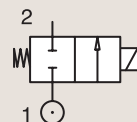

Raccord	Orifice Ø	Facteur d'Écoulement			Pression Différentielle			Temp. Fluide		Joint	Electrovannes PARKER LUCIFER®			IS	Puissance		Groupe Electrique	N° Schéma
					Min	Max		Min	Max		Ref. Valve	Ref. Boîtier	Ref. Bobine		AC W	DC W		
		bar	AC bar	DC bar	°C	°C												
1/8"	1.5	0.9	0.054	70	0	20	12	-10	75	FKM	121M14	8993	481180		4	5	1.1	3382
	1.5	0.9	0.054	70	0	20	4	-10	75	FKM	121M14	8993	488980		2	2.5	1.1	3382
	1.5	1.5	0.09	80	0	60	25	-30	75	PCTFE	E121K14	2995	481865		8	9	2.0	3510
	1.5	1.5	0.09	80	0	70	30	-30	75	PCTFE	E121K14	4270	481000		8	8	2.0	3510
	1.5	1.5	0.09	80	0	70	55	-30	75	PCTFE	E121K14	4270	486265		14	14	2.0	3510
	2	2	0.12	125	0	10	7	-10	75	FKM	121M13	8993	481180		4	5	1.1	3382
	2	2	0.12	125	0	10	2.5	-10	75	FKM	121M13	8993	488980		2	2.5	1.1	3382
	2.5	3.5	0.21	220	0	28	10	-30	100	Ruby	E121K23	2995	481865		8	9	2.0	3510
	2.5	3.5	0.21	220	0	34	12	-30	130	Ruby	E121K23	4270	481000		8	8	2.0	3510
	2.5	3.5	0.21	220	0	50	22	-30	120	Ruby	E121K23	4270	486265		14	14	2.0	3510
	3	4.5	0.27	320	0	10	7	-10	100	FKM	121K1302	2995	481865		8	9	2.0	3510
3	4.5	0.27	320	0	10	8	-10	120	FKM	121K1302	4270	481000		8	8	2.0	3510	
3	4.5	0.27	320	0	10	10	-10	120	FKM	121K1302	4270	486265		14	14	2.0	3510	
1/4"	1.2	0.85	0.051	50	0	80	36	-30	100	Ruby	E121K65	2995	481865		8	9	2.0	3510
	1.2	0.85	0.051	50	0	100	43	-30	130	Ruby	E121K65	4270	481000		8	8	2.0	3510
	1.2	0.85	0.051	50	0	100	75	-30	120	Ruby	E121K65	4270	486265		14	14	2.0	3510
	1.5	1.5	0.09	80	0	-	8	-20	75	PUR	121K0497 ₁	2995	482740		-	1.6	6.0/8.0	8274
	1.5	1.5	0.09	80	0	10	10	-20	75	PUR	121K0497 ₁	-	495900		2.5	2	6.0/8.0	8274
	1.5	1.5	0.09	80	0	-	10	-20	75	PUR	121K0497 ₁	-	495910	*	-	0.3 to 3	6.0/8.0	8274
	1.5	1.5	0.09	80	0	-	8	-20	75	PUR	121K0497 ₁	2995	496125		-	1.6	6.0/8.0	8274
	1.5	1.5	0.09	80	0	60	25	-30	75	PCTFE	E121K04	2995	481865		8	9	2.0	3510
	1.5	1.5	0.09	80	0	70	30	-30	75	PCTFE	E121K04	4270	481000		8	8	2.0	3510
	1.5	1.5	0.09	80	0	70	55	-30	75	PCTFE	E121K04	4270	486265		14	14	2.0	3510
	1.5	1.5	0.09	80	0	20	20	-10	100	FKM	E121K0402	2995	481865		8	9	2.0/3.0	3510
	1.5	1.5	0.09	80	0	20	20	-10	120	FKM	E121K0402	4270	481000		8	8	2.0/3.0	3510
	1.5	1.5	0.09	80	0	60	25	-30	100	Ruby	E121K67	2995	481865		8	9	2.0	3510
	1.5	1.5	0.09	80	0	75	30	-30	130	Ruby	E121K67	4270	481000		8	8	2.0	3510
	1.5	1.5	0.09	80	0	100	55	-30	120	Ruby	E121K67	4270	486265		14	14	2.0	3510
	2.5	3.5	0.21	220	0	14	7	-10	100	FKM	121K0706	2995	481865		8	9	2.0	3510
	2.5	3.5	0.21	220	0	14	9	-10	120	FKM	121K0706	4270	481000		8	8	2.0	3510
	2.5	3.5	0.21	220	0	14	14	-10	120	FKM	121K0706	4270	486265		14	14	2.0	3510
2.5	3.5	0.21	220	0	28	10	-30	75	PCTFE	E121K07	2995	481865		8	9	2.0	3510	
2.5	3.5	0.21	220	0	34	12	-30	75	PCTFE	E121K07	4270	481000		8	8	2.0	3510	
2.5	3.5	0.21	220	0	50	22	-30	75	PCTFE	E121K07	4270	486265		14	14	2.0	3510	

Notes:

1. Valve compatible avec l'eau uniquement jusqu'à 40°C



Dans cette page	Raccord	Orifice (mm)	Kv (l/min)	Pression Diff. Max. (bar)	Temp. Fluide (°C)	Temp. Amb. (°C)
de	1/8"	1.2	0.9	2.5	-30	-20
à	1/4"	3	4.5	100	130	50



Schéma 3382



Schéma 3510

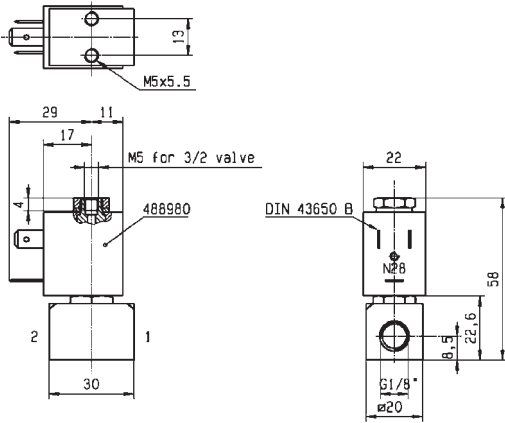

Schéma 8274

2/2

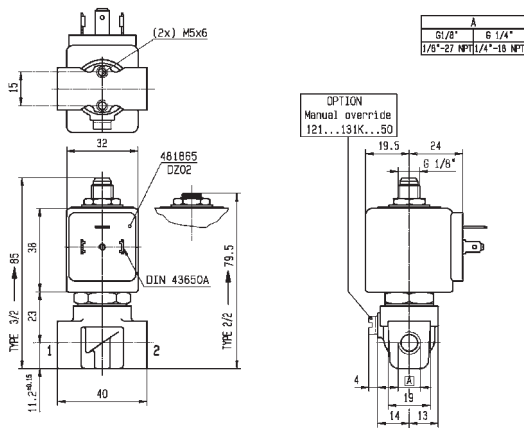
ELECTROVANNES POUR AIR SEC OU LUBRIFIÉ, GAZ ET LIQUIDES NEUTRES COMMANDE DIRECTE

LAITON

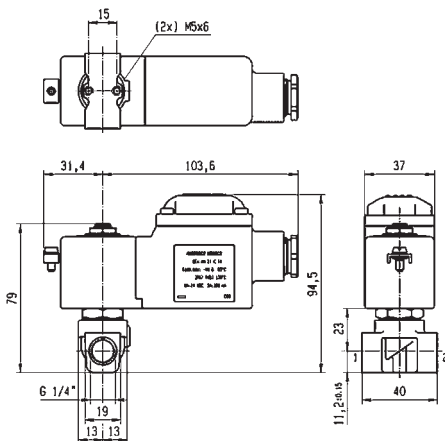
RACCORD TUYAU

FERMÉE HORS TENSION

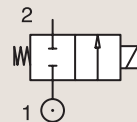

Raccord BSP	Orifice Ø mm	Facteur d'Écoulement			Pression Différentielle			Temp. Fluide		Joint	Electrovannes PARKER LUCIFER®			IS	Puissance		Groupe Electrique	N° Schéma
		Kv l/min	KV m³/h	Qn l/min	Min bar	Max AC bar DC bar		Min °C	Max °C		Ref. Valve	Ref. Boîtier	Ref. Bobine		AC W	DC W		
1/4"	2.5	3.5	0.21	220	0	28	10	-30	100	Ruby	E121K63	2995	481865	8	9	2.0	3510	
	2.5	3.5	0.21	220	0	34	12	-30	130	Ruby	E121K63	4270	481000	8	8	2.0	3510	
	2.5	3.5	0.21	220	0	50	22	-30	120	Ruby	E121K63	4270	486265	14	14	2.0	3510	
	3	3.5	0.21	250	0	-	2	-20	75	PUR	121K0397 ₂	2995	482740	-	1.6	6.0/8.0	8274	
	3	3.5	0.21	250	0	4.5	4	-20	75	PUR	121K0397 ₂	-	495900	2.5	2	6.0/8.0	8274	
	3	3.5	0.21	250	0	-	4.5	-20	75	PUR	121K0397 ₂	-	495910	*	-	0.3 to 3	6.0/8.0	8274
	3	3.5	0.21	250	0	-	2	-20	75	PUR	121K0397 ₂	2995	496125	-	1.6	6.0/8.0	8274	
	3	4.5	0.27	320	0	20	7	-30	75	PCTFE	E121K03	2995	481865	8	9	2.0/3.0	3510	
	3	4.5	0.27	320	0	25	8.5	-30	75	PCTFE	E121K03	4270	481000	8	8	2.0/3.0	3510	
	3	4.5	0.27	320	0	36	15	-30	75	PCTFE	E121K03	4270	486265	14	14	2.0/3.0	3510	
	3	4.5	0.27	320	0	10	7	-10	100	FKM	E121K0302	2995	481865	8	9	2.0	3510	
	3	4.5	0.27	320	0	10	8.5	-10	120	FKM	E121K0302	4270	481000	8	8	2.0	3510	
	3	4.5	0.27	320	0	10	7	-10	100	FKM	E121K0302	4270	486265	14	14	2.0	3510	
	3	4.5	0.27	320	0	10	7	-10	100	FKM	E121K0352 ₁	2995	481865	8	9	2.0	3510	
	3	4.5	0.27	320	0	10	8.5	-10	120	FKM	E121K0352 ₁	4270	481000	8	8	2.0	3510	
	3	4.5	0.27	320	0	10	10	-10	120	FKM	E121K0352 ₁	4270	486265	14	14	2.0	3510	
	3	4.5	0.27	320	0	20	7	-30	100	Ruby	E121K64	2995	481865	8	9	2.0	3510	
	3	4.5	0.27	320	0	25	8.5	-30	130	Ruby	E121K64	4270	481000	8	8	2.0	3510	
	3	4.5	0.27	320	0	36	15	-30	120	Ruby	E121K64	4270	486265	14	14	2.0	3510	
	4	7.5	0.45	480	0	10	4	-10	100	FKM	121K02	2995	481865	8	9	2.0	3510	
	4	7.5	0.45	480	0	10	5	-10	120	FKM	121K02	4270	481000	8	8	2.0	3510	
	4	7.5	0.45	480	0	10	10	-10	120	FKM	121K02	4270	486265	14	14	2.0	3510	
	4	7.5	0.45	480	0	10	4	-10	100	FKM	121K0250 ₁	2995	481865	8	9	2.0	3510	
	4	7.5	0.45	480	0	10	5	-10	120	FKM	121K0250 ₁	4270	481000	8	8	2.0	3510	
	4	7.5	0.45	480	0	10	10	-10	120	FKM	121K0250 ₁	4270	486265	14	14	2.0	3510	
	5	11	0.66	750	0	7	2	-10	100	FKM	121K01	2995	481865	8	9	2.0/14.2	3510	
	5	11	0.66	750	0	7	2.8	-10	120	FKM	121K01	4270	481000	8	8	2.0/14.2	3510	
	5	11	0.66	750	0	7	5	-10	120	FKM	121K01	4270	486265	14	14	2.0/14.2	3510	
	5	11	0.66	750	0	7	2	-10	100	FKM	121K0106	2995	481865	8	9	2.0	3510	
	5	11	0.66	750	0	7	2.8	-10	120	FKM	121K0106	4270	481000	8	8	2.0	3510	
5	11	0.66	750	0	7	5	-10	120	FKM	121K0106	4270	486265	14	14	2.0	3510		
5	11	0.66	750	0	7	2	-10	100	FKM	121K0150 ₁	2995	481865	8	9	2.0	3510		
5	11	0.66	750	0	7	2.8	-10	120	FKM	121K0150 ₁	4270	481000	8	8	2.0	3510		
5	11	0.66	750	0	7	5	-10	120	FKM	121K0150 ₁	4270	486265	14	14	2.0	3510		

Notes:

- 1. Avec Commande manuelle
- 2. Valve compatible avec l'eau uniquement jusqu'à 40°C



Dans cette page	Raccord	Orifice (mm)	Kv (l/min)	Pression Diff. Max. (bar)	Temp. Fluide (°C)	Temp. Amb. (°C)
de	1/4"	2,5	3,5	2	-30	-20
à	1/4"	5	11	50	130	50



Schéma 3510



Schéma 8274

2/2

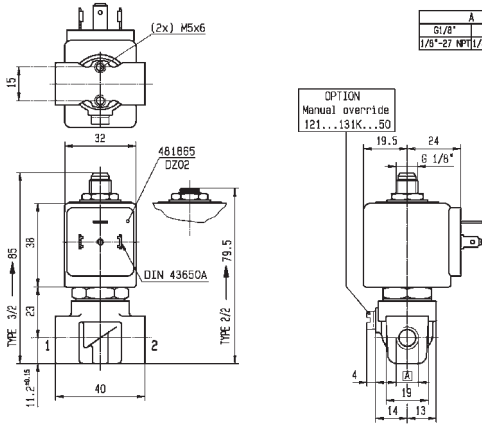
ELECTROVANNES POUR AIR SEC OU LUBRIFIÉ, GAZ ET LIQUIDES NEUTRES COMMANDE DIRECTE

LAITON

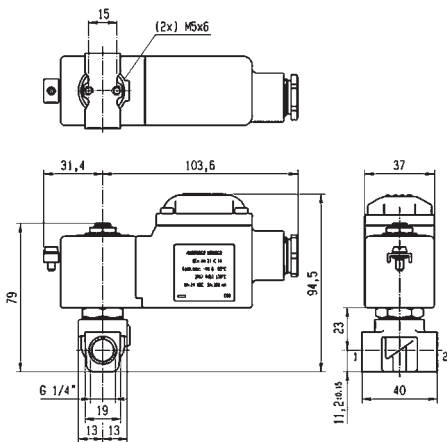
RACCORD TUYAU

FERMÉE HORS TENSION

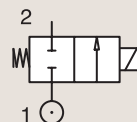

Raccord BSP	Orifice Ø mm	Facteur d'Écoulement			Pression Différentielle			Temp. Fluide		Joint	Electrovannes PARKER LUCIFER®			Puissance		Groupe Électrique	N° Schéma
		Kv l/min	KV m³/h	Qn l/min	Min bar	Max AC bar	DC bar	Min °C	Max °C		Ref. Valve	Ref. Boîtier	Ref. Bobine	AC W	DC W		
3/8"	4	7.5	0.45	480	0	10	4	-10	100	FKM	121K3206	2995	481865	8	9	2.0	3551
	4	7.5	0.45	480	0	10	5	-10	120	FKM	121K3206	4270	481000	8	8	2.0	3551
	4	7.5	0.45	480	0	10	10	-10	120	FKM	121K3206	4270	486265	14	14	2.0	3551
	5	11	0.66	750	0	7	2	-10	100	FKM	121K3106	2995	481865	8	9	2.0	3551
	5	11	0.66	750	0	7	2.8	-10	120	FKM	121K3106	4270	481000	8	8	2.0	3551
	5	11	0.66	750	0	7	5	-10	120	FKM	121K3106	4270	486265	14	14	2.0	3551
	6	12	0.72	1100	0	5	1.1	-10	100	FKM	121K3306	2995	481865	8	9	2.0/14.2	3551
	6	12	0.72	1100	0	5	1.5	-10	120	FKM	121K3306	4270	481000	8	8	2.0/14.2	3551
	6	12	0.72	1100	0	5	3	-10	120	FKM	121K3306	4270	486265	14	14	2.0/14.2	3551
1/2"	8.5	25	1.5	1600	0	1.1	0.5	-10	100	FKM	E121K46	2995	481865	8	9	2.0	3427
	8.5	25	1.5	1600	0	2.2	0.5	-10	120	FKM	E121K46	4270	481000	8	8	2.0	3427
	8.5	25	1.5	1600	0	4	1.2	-10	120	FKM	E121K46	4270	486265	14	14	2.0	3427
	11	36	2.16	2500	0	0.7	0.3	-10	100	FKM	E121K45	2995	481865	8	9	2.0	3427
	11	36	2.16	2500	0	1.2	0.35	-10	120	FKM	E121K45	4270	481000	8	8	2.0	3427
	11	36	2.16	2500	0	2.5	0.7	-10	120	FKM	E121K45	4270	486265	14	14	2.0	3427



Dans cette page	Raccord	Orifice (mm)	Kv (l/min)	Pression Diff. Max. (bar)	Temp. Fluide (°C)	Temp. Amb. (°C)
de	3/8"	4	7.5	0.3	-10	-10
à	1/2"	11	36	10	120	50



Schéma 3551



Schéma 3427

2/2

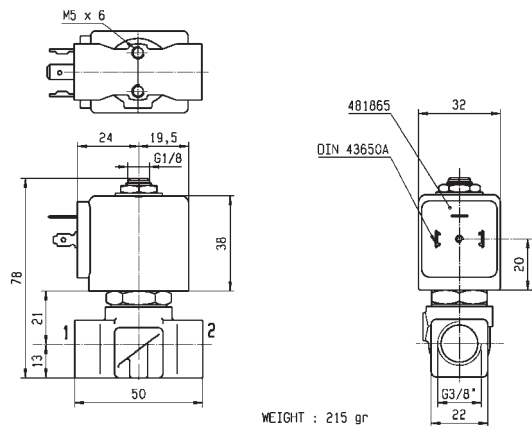
ELECTROVANNES POUR AIR SEC OU LUBRIFIÉ, GAZ ET LIQUIDES NEUTRES COMMANDE DIRECTE

LAITON

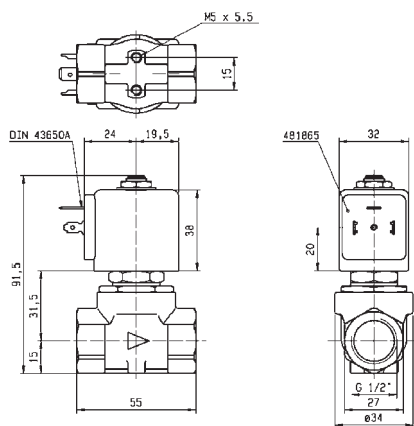
RACCORD TUYAU

OUVERTE HORS TENSION

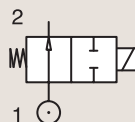

Raccord BSP	Orifice Ø mm	Facteur d'Écoulement			Pression Différentielle			Temp. Fluide		Joint	Electrovannes PARKER			Puissance		Groupe Electrique	N° Schéma
		Kv l/min	KV m³/h	Qn m³/h	Min bar	Max AC bar	DC bar	Min °C	Max °C		N° Commande Valve	Type de Valve	Type de Bobine	AC W	DC W		
1/4"	1.5	1.3	0.078	-	0	22	-	-10	140	FKM	363475	PM151GV	ZB09	9	-	20.1/20.2	036
	1.5	1.3	0.078	-	0	-	22	-10	140	FKM	363475	PM151GV	ZB12	-	12	20.1/20.2	036
	2	1.8	0.11	-	0	18	-	-10	140	FKM	362290	PM136.2FV	ZB14	14	-	20.2	020
	2	1.8	0.11	-	0	-	18	-10	140	FKM	362290	PM136.2FV	ZB16	-	16	20.2	020
	2	2.5	0.15	-	0	12	-	-10	140	FKM	363570	PM151HV	ZB09	9	-	20.1/20.2	036
	2	2.5	0.15	-	0	-	12	-10	140	FKM	363570	PM151HV	ZB12	-	12	20.1/20.2	036
	3	4	0.24	-	0	5.5	-	-10	140	FKM	363282	PM136YV	ZB14	14	-	20.2	020
	3	4	0.24	-	0	-	5.5	-10	140	FKM	363282	PM136YV	ZB16	-	16	20.2	020



Dans cette page	Raccord	Orifice (mm)	Kv (l/min)	Pression Diff. Max. (bar)	Temp. Fluide (°C)	Temp. Amb. (°C)
de	1/4"	1.5	1.3	5.5	-10	-10
à	1/4"	3	4	22	140	50



Schéma 036



Schéma 020

2/2

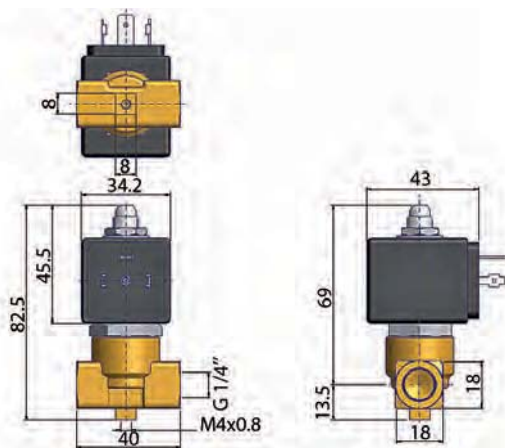
ELECTROVANNES POUR AIR SEC OU LUBRIFIÉ, GAZ ET LIQUIDES NEUTRES COMMANDE DIRECTE

LAITON

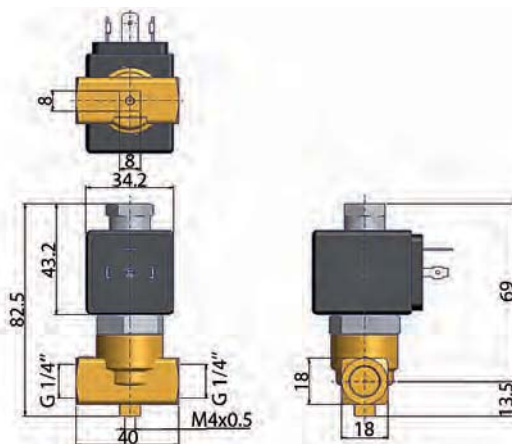
RACCORD TUYAU

OUVERTE HORS TENSION

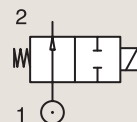

Raccord	Orifice Ø	Facteur d'Écoulement			Pression Différentielle			Temp. Fluide		Joint	Electrovannes PARKER LUCIFER®			Puissance		Groupe Electrique	N° Schéma
											Ref. Valve	Ref. Boîtier	Ref. Bobine	AC W	DC W		
1/8"	2.5	3.5	0.21	-	0	30	-	-30	140	Ruby	122K9363	4270	481044	14	-	2.2	3510
	2.5	3.5	0.21	-	0	30	30	-30	140	Ruby	122K9363	4270	486265	14	14	2.2	3510
1/4"	1.5	1.5	0.09	9.6	0	30	30	-10	100	PCTFE	122K84	2995	481865	8	9	2.1	3510
	1.5	1.5	0.09	9.6	0	30	30	-10	100	PCTFE	122K84	4270	481000	8	8	2.1	3510
	1.5	1.5	0.09	9.6	0	30	30	-10	120	PCTFE	122K84	4270	486265	14	14	2.0	3510
	1.5	1.5	0.09	80	0	20	20	-10	100	FKM	122K8406	2995	481865	8	9	2.1	3510
	1.5	1.5	0.09	80	0	20	20	-10	120	FKM	122K8406	4270	481000	8	8	2.1	3510
	1.5	1.5	0.09	80	0	40	40	-30	100	Ruby	122K8408	2995	481865	8	9	2.1	3510
	1.5	1.5	0.09	80	0	40	40	-30	130	Ruby	122K8408	4270	481000	8	8	2.1	3510
	1.5	1.5	0.09	80	0	40	40	-30	130	Ruby	122K8408	4270	486265	14	14	2.0	3510
	2.5	3	0.18	180	0	12	12	-30	75	PCTFE	122K83	2995	481865	8	9	2.1	3510
	2.5	3	0.18	180	0	12	12	-30	75	PCTFE	122K83	4270	481000	8	8	2.1	3510
	2.5	3	0.18	180	0	12	12	-30	75	PCTFE	122K83	4270	486265	14	14	2.0	3510
	2.5	3	0.18	180	0	12	12	-10	100	FKM	122K8306	2995	481865	8	9	2.0	3510
	2.5	3	0.18	180	0	12	12	-10	120	FKM	122K8306	4270	481000	8	8	2.0	3510
	2.5	3	0.18	180	0	12	12	-10	120	FKM	122K8306	4270	486265	14	14	2.0	3510
2.5	3.5	0.21	-	0	30	-	-30	140	Ruby	122K8363	4270	481044	14	-	2.2	3510	
2.5	3.5	0.21	-	0	30	30	-30	140	Ruby	122K8363	4270	486265	14	14	2.2	3510	

LAITON

RACCORD TUYAU

COMMANDE PAR IMPULSION

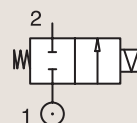

Raccord	Orifice Ø	Facteur d'Écoulement			Pression Différentielle			Temp. Fluide		Joint	Electrovannes PARKER LUCIFER®			Puissance		Groupe Electrique	N° Schéma
											Ref. Valve	Ref. Boîtier	Ref. Bobine	AC W	DC W		
1/4"	3	4.5	0.27	320	0	20	-	-30	75	PCTFE	125K03	4269	484990	11	-	4.0	8296
	3	4.5	0.27	320	0	-	7	-30	75	PCTFE	125K03	4269	485400	-	13	4.0	8296
1/4"	5	11	0.66	750	0	5	-	-10	100	FKM	125K01	4269	484990	11	-	4.0	8296
	5	11	0.66	750	0	-	1.5	-10	100	FKM	125K01	4269	485400	-	13	4.0	8296



Dans cette page	Raccord	Orifice (mm)	Kv (l/min)	Pression Diff. Max. (bar)	Temp. Fluide (°C)	Temp. Amb. (°C)
de	1/8"	1.5	1.5	1.5	-30	-10
à	1/4"	5	11	40	140	50



Schéma 3510



Schéma 8296

2/2

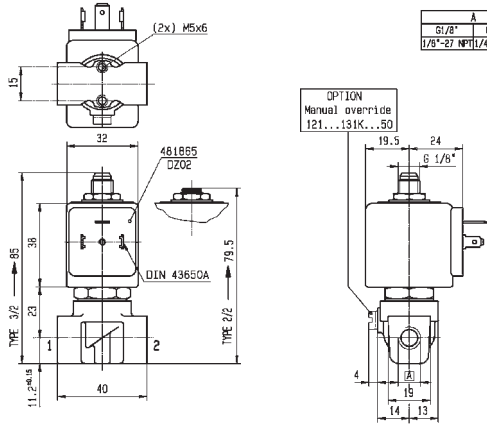
ELECTROVANNES POUR AIR SEC OU LUBRIFIÉ, GAZ ET LIQUIDES NEUTRES COMMANDE DIRECTE

LAITON

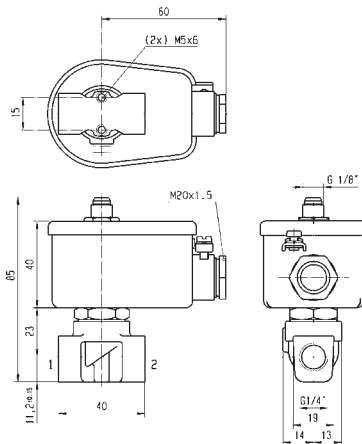
MONTAGE SUR EMBASE

FERMÉE HORS TENSION

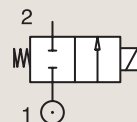

Raccord	Orifice Ø	Facteur d'Écoulement			Pression Différentielle			Temp. Fluide		Joint	Electrovannes PARKER LUCIFER®			Puissance		Groupe Electrique	N° Schéma
					Min	Max		Min	Max		Ref. Valve	Ref. Boîtier	Ref. Bobine	AC W	DC W		
		bar	AC bar	DC bar	°C	°C											
SB	1.5	1.5	0.09	80	0	20	-	-10	100	EPDM	121F4417	2995	483510	9	-	2.0	3509
	1.5	1.5	0.09	80	0	60	25	-30	100	Ruby	121F67	2995	481865	8	9	2.0	3509
	1.5	1.5	0.09	80	0	75	30	-30	130	Ruby	121F67	4270	481000	8	8	2.0	3509
	1.5	1.5	0.09	80	0	100	55	-30	120	Ruby	121F67	4270	486265	14	14	2.0	3509
	1.5	1.5	0.09	80	0	60	25	-30	75	PCTFE	E121F44	2995	481865	8	9	2.0	3509
	1.5	1.5	0.09	80	0	70	30	-30	75	PCTFE	E121F44	4270	481000	8	8	2.0	3509
	1.5	1.5	0.09	80	0	70	55	-30	75	PCTFE	E121F44	4270	486265	14	14	2.0	3509
	1.5	1.5	0.09	80	0	20	20	-10	100	FKM	E121F4406	2995	481865	8	9	2.0	3509
	1.5	1.5	0.09	80	0	20	20	-10	120	FKM	E121F4406	4270	481000	8	8	2.0	3509
	1.5	1.5	0.09	80	0	20	20	-10	120	FKM	E121F4406	4270	486265	14	14	2.0	3509
	2.5	3.5	0.21	220	0	28	10	-30	75	PCTFE	121F47	2995	481865	8	9	2.0	3509
	2.5	3.5	0.21	220	0	34	12	-30	75	PCTFE	121F47	4270	481000	8	8	2.0	3509
	2.5	3.5	0.21	220	0	50	22	-30	75	PCTFE	121F47	4270	486265	14	14	2.0	3509
	2.5	3.5	0.21	220	0	14	7	-10	100	FKM	121F4706	2995	481865	8	9	2.0	3509
	2.5	3.5	0.21	220	0	14	9	-10	120	FKM	121F4706	4270	481000	8	8	2.0	3509
	2.5	3.5	0.21	220	0	14	14	-10	120	FKM	121F4706	4270	486265	14	14	2.0	3509
	2.5	3.5	0.21	220	0	28	10	-30	100	Ruby	121F63	2995	481865	8	9	2.0	3509
	2.5	3.5	0.21	220	0	34	12	-30	130	Ruby	121F63	4270	481000	8	8	2.0	3509
	2.5	3.5	0.21	220	0	50	22	-30	120	Ruby	121F63	4270	486265	14	14	2.0	3509
	3	4.5	0.27	320	0	10	-	-10	100	FKM	121F4317	2995	483510	9	-	2.0	3509
	3	4.5	0.27	320	0	20	7	-30	100	Ruby	121F64	2995	481865	8	9	2.0	3509
	3	4.5	0.27	320	0	25	8.5	-30	130	Ruby	121F64	4270	481000	8	8	2.0	3509
	3	4.5	0.27	320	0	36	15	-30	120	Ruby	121F64	4270	486265	14	14	2.0	3509
	3	4.5	0.27	320	0	20	7	-30	75	PCTFE	E121F43	2995	481865	8	9	2.0	3509
	3	4.5	0.27	320	0	25	8.5	-30	75	PCTFE	E121F43	4270	481000	8	8	2.0	3509
	3	4.5	0.27	320	0	36	15	-30	75	PCTFE	E121F43	4270	486265	14	14	2.0	3509
	3	4.5	0.27	320	0	10	7	-10	100	FKM	E121F4302	2995	481865	8	9	2.0/3.0	3509
	3	4.5	0.27	320	0	10	8.5	-10	120	FKM	E121F4302	4270	481000	8	8	2.0/3.0	3509
	3	4.5	0.27	320	0	10	10	-10	120	FKM	E121F4302	4270	486265	14	14	2.0/3.0	3509



Dans cette page	Raccord	Orifice (mm)	Kv (l/min)	Pression Diff. Max. (bar)	Temp. Fluide (°C)	Temp. Amb. (°C)
de	5 mm	1.5	1.5	7	-30	-10
à	5 mm	3	4.5	100	130	50

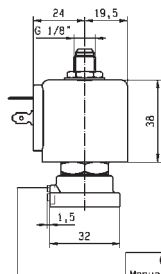
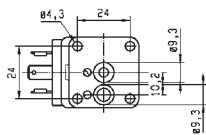

OPTION
Manual override
121...131F...50



Schéma 3509

2/2

ELECTROVANNES POUR AIR SEC OU LUBRIFIÉ,
GAZ ET LIQUIDES NEUTRES
COMMANDE DIRECTE

LAITON

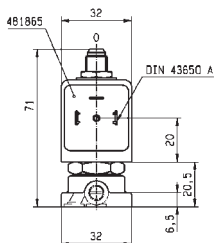
MONTAGE SUR EMBASE

OUVERTE HORS TENSION

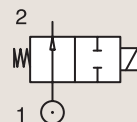

Raccord	Orifice Ø	Facteur d'Écoulement			Pression Différentielle			Temp. Fluide		Joint	Electrovannes PARKER LUCIFER®			Puissance		Groupe Electrique	N° Schéma
					Min	Max		Min	Max		Ref. Valve	Ref. Boîtier	Ref. Bobine	AC W	DC W		
		bar	AC bar	DC bar	°C	°C	AC W	DC W									
SB	1.5	1.5	0.09	80	0	20	20	-10	100	FKM	122F44	2995	481865	8	9	2.1	3509
	1.5	1.5	0.09	80	0	20	20	-10	120	FKM	122F44	4270	481000	8	8	2.1	3509



Dans cette page	Raccord	Orifice (mm)	Kv (l/min)	Pression Diff. Max. (bar)	Temp. Fluide (°C)	Temp. Amb. (°C)
de	5 mm	1.5	1.5	20	-10	-10
à	5 mm	1.5	1.5	20	120	50

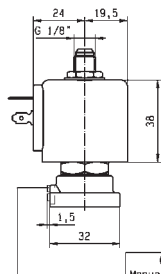
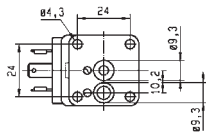

OPTION
Manual override
121...131F...50



Schéma 3509

2/2

ELECTROVANNES POUR AIR SEC OU LUBRIFIÉ, GAZ ET LIQUIDES NEUTRES ATTRACTION FORCÉE

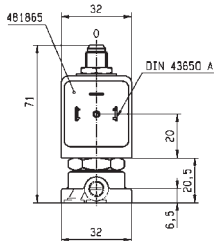

Equipement Commercial



Equipement Industriel

LAITON
RACCORD TUYAU

FERMÉE HORS TENSION

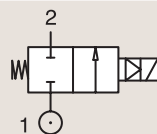

Raccord	Orifice Ø	Facteur d'Écoulement			Pression Différentielle			Temp. Fluide		Joint	Electrovannes PARKER			Puissance		Groupe Electrique	N° Schéma
		Kv l/min	KV m³/h	Qn m³/h	Min bar	Max AC bar	DC bar	Min °C	Max °C		N° Commande Valve	Type de Valve	Type de Bobine	AC W	DC W		
3/8"	13	40	2.4	-	0	5	-	-10	140	FKM	361810	PM123IV	ZB09	9	-	20.1	004
1/2"	13	40	2.4	-	0	5	-	-10	140	FKM	361850	PM123AV	ZB09	9	-	20.1	003
3/4"	20	100	6	-	0	3	-	-10	140	FKM	361910	PM123CV	JB14	14	-	21.0	005
1"	25	117	7	-	0	3	-	-10	140	FKM	361950	PM123DV	JB14	14	-	21.0	006



Dans cette page	Raccord	Orifice (mm)	Kv (l/min)	Pression Diff. Max. (bar)	Temp. Fluide (°C)	Temp. Amb. (°C)
de	3/8"	13	40	3	-10	-10
à	1"	25	117	5	140	50



Schéma 004



Schéma 003

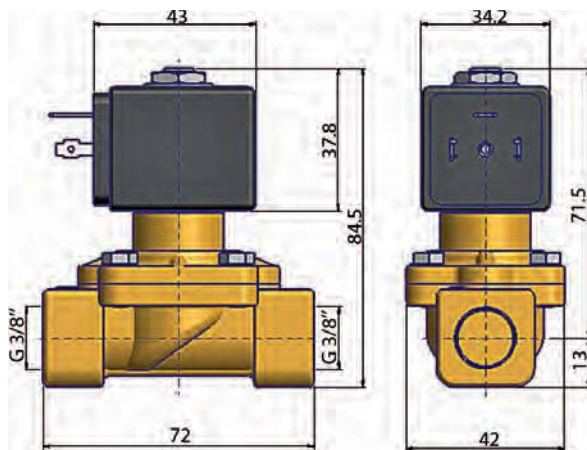

Schéma 005

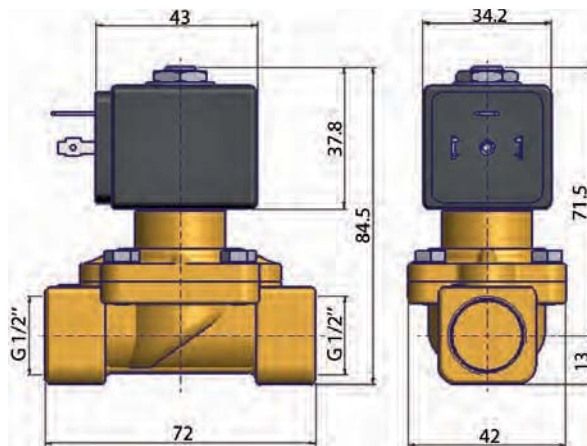

Schéma 006

2/2

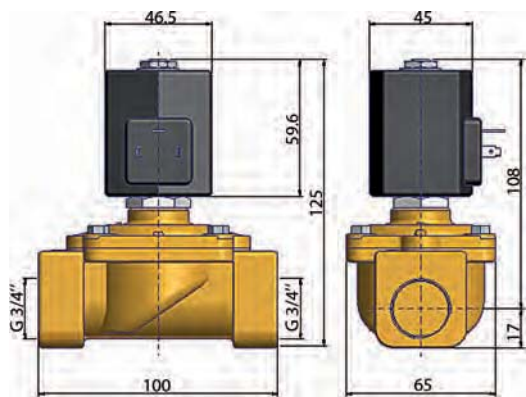
ELECTROVANNES POUR AIR SEC OU LUBRIFIÉ, GAZ ET LIQUIDES NEUTRES ATTRACTION FORCÉE

LAITON

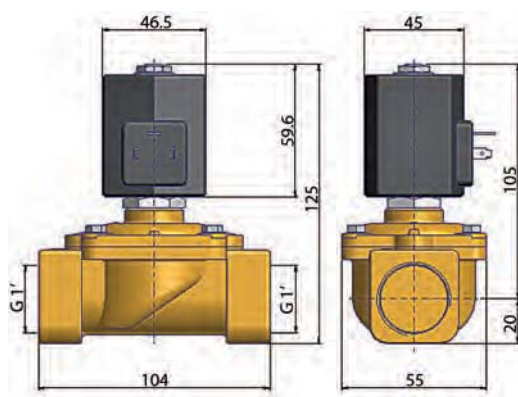
RACCORD TUYAU

FERMÉE HORS TENSION

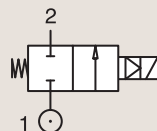

Raccord BSP	Orifice Ø mm	Facteur d'Écoulement			Pression Différentielle			Temp. Fluide		Joint	Electrovannes PARKER LUCIFER®			Puissance		Groupe Electrique	N° Schéma
		Kv l/min	KV m³/h	Qn l/min	Min bar	Max AC bar	DC bar	Min °C	Max °C		Ref. Valve	Ref. Boîtier	Ref. Bobine	AC W	DC W		
3/8"	15	65	3.9	4500	0	16	-	-10	100	NBR	221G13	2995	481865	8	-	2.0	3732
	15	65	3.9	4500	0	16	-	-10	100	NBR	221G13	4270	481000	8	-	2.0	3732
	15	65	3.9	4500	0	16	16	-10	100	NBR	221G13	4270	486265	14	14	2.0	3732
	15	65	3.9	4500	0	16	-	0	100	FKM	221G23 ₃	2995	481865	8	-	2.0	3732
	15	65	3.9	4500	0	16	-	0	120	FKM	221G23 ₃	4270	481000	8	-	2.0	3732
	15	65	3.9	4500	0	20	7	0	140	FKM	221G23 ₃	4270	486265	14	14	2.0	3732
	15	65	3.9	4500	0	-	10	-10	100	FKM	221G2330 ₂₃	2995	481865	-	9	2.1	3732
	15	65	3.9	4500	0	10	10	-10	100	FKM	221G2330 ₂₃	-	492070	9	8	2.1	3732
	15	65	3.9	4500	0	10	10	-10	100	FKM	221G2330 ₂₃	-	492190	11	9	2.1	3732
1/2"	15	65	3.9	4500	0	16	-	-10	100	NBR	221G15	2995	481865	8	-	2.0	3732
	15	65	3.9	4500	0	16	-	-10	100	NBR	221G15	4270	481000	8	-	2.0	3732
	15	65	3.9	4500	0	16	7	-10	100	NBR	221G15	4270	486265	14	14	2.0	3732
	15	65	3.9	4500	0	-	10	-10	100	FKM	221G1530 ₂	2995	481865	-	9	2.1	3732
	15	65	3.9	4500	0	10	10	-10	120	FKM	221G1530 ₂	-	492070	9	8	2.1	3732
	15	65	3.9	4500	0	10	10	-10	120	FKM	221G1530 ₂	-	492190	11	9	2.1	3732
	15	65	3.9	4500	0	16	-	0	100	FKM	221G25 ₃	2995	481865	8	-	2.0	3732
	15	65	3.9	4500	0	16	-	0	120	FKM	221G25 ₃	4270	481000	8	-	2.0	3732
	15	65	3.9	4500	0	20	7	0	140	FKM	221G25 ₃	4270	486265	14	14	2.0	3732
	15	65	3.9	4500	0	-	10	-10	100	FKM	221G2530 ₂₃	2995	481865	-	9	2.1	3732
	15	65	3.9	4500	0	10	10	-10	100	FKM	221G2530 ₂₃	-	492070	9	8	2.1	3732
	15	65	3.9	4500	0	10	10	-10	100	FKM	221G2530 ₂₃	-	492190	11	9	2.1	3732

Notes:

1. Avec vis de réglage du temps de fermeture (4 positions)
2. Tension continue uniquement (ou bobine avec pont redresseur)
3. Valve uniquement compatible avec huile hydraulique, air et gaz neutres



Dans cette page	Raccord	Orifice (mm)	Kv (l/min)	Pression Diff. Max. (bar)	Temp. Fluide (°C)	Temp. Amb. (°C)
de	3/8"	15	65	7	-10	-10
à	1/2"	15	65	20	140	50



Schéma 3732

2/2

ELECTROVANNES POUR AIR SEC OU LUBRIFIÉ, GAZ ET LIQUIDES NEUTRES ATTRACTION FORCÉE

LAITON

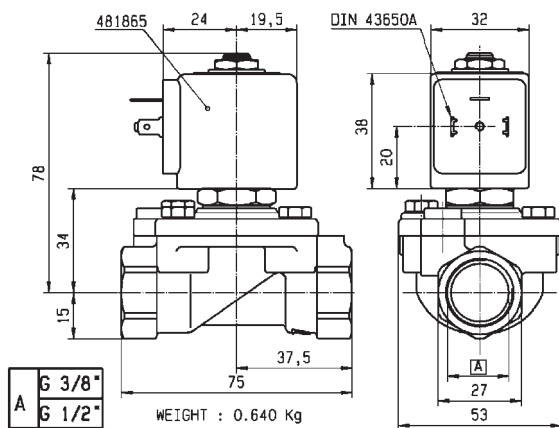
RACCORD TUYAU

FERMÉE HORS TENSION

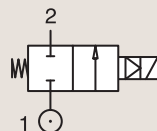

Raccord BSP	Orifice Ø mm	Facteur d'Écoulement			Pression Différentielle			Temp. Fluide		Joint	Electrovannes PARKER LUCIFER®			Puissance		Groupe Electrique	N° Schéma
		Kv l/min	KV m³/h	Qn l/min	Min bar	Max AC bar	DC bar	Min °C	Max °C		Ref. Valve	Ref. Boîtier	Ref. Bobine	AC W	DC W		
3/4"	15	80	4.8	6000	0	16	-	-10	100	FKM	221G16	2995	481865	8	-	2.0	3444
	15	80	4.8	6000	0	16	-	-10	100	FKM	221G16	4270	481000	8	-	2.0	3444
	15	80	4.8	6000	0	7	7	-10	100	FKM	221G16	4270	486265	14	14	2.0	3444
	15	80	4.8	6000	0	16	-	-10	100	NBR	221G1610 ₁	2995	481865	8	-	2.0	3444
	15	80	4.8	6000	0	16	-	-10	100	NBR	221G1610 ₁	4270	481000	8	-	2.0	3444
	15	80	4.8	6000	0	16	7	-10	100	NBR	221G1610 ₁	4270	486265	14	14	2.0	3444
	15	80	4.8	6000	0	10	10	-10	100	FKM	221G1630 ₂	2995	481865	8	9	2.1	3444
	15	80	4.8	6000	0	10	10	-25	40	FKM	221G1630 ₂	-	492070	9	8	2.1	3444
	15	80	4.8	6000	0	10	10	-25	40	FKM	221G1630 ₂	-	492190	11	9	2.1	3444
	15	80	4.8	6000	0	10	10	-10	100	FKM	221G1631 ₁₂	2995	481865	8	9	2.1	3444
	15	80	4.8	6000	0	10	10	-25	40	FKM	221G1631 ₁₂	-	492070	9	8	2.1	3444
	15	80	4.8	6000	0	10	10	-25	40	FKM	221G1631 ₁₂	-	492190	11	9	2.1	3444
	15	80	4.8	6000	0	16	-	0	100	FKM	221G26 ₃	2995	481865	8	-	2.0	3444
	15	80	4.8	6000	0	16	-	0	120	FKM	221G26 ₃	4270	481000	8	-	2.0	3444
	15	80	4.8	6000	0	20	7	0	140	FKM	221G26 ₃	4270	486265	14	14	2.0	3444
	15	80	4.8	6000	0	-	10	-10	100	FKM	221G2630 ₂₃	2995	481865	-	9	2.1	3444
	15	80	4.8	6000	0	10	10	-25	40	FKM	221G2630 ₂₃	-	492070	9	8	2.1	3444
	15	80	4.8	6000	0	10	10	-25	40	FKM	221G2630 ₂₃	-	492190	11	9	2.1	3444

Notes:

1. Avec vis de réglage du temps de fermeture (4 positions)
2. Tension continue uniquement (ou bobine avec pont redresseur)
3. Valve uniquement compatible avec huile hydraulique, air et gaz neutres



Dans cette page	Raccord	Orifice (mm)	Kv (l/min)	Pression Diff. Max. (bar)	Temp. Fluide (°C)	Temp. Amb. (°C)
de	3/4"	15	80	7	-25	-10
à	3/4"	15	80	20	140	50



Schéma 3444

2/2

ELECTROVANNES POUR AIR SEC OU LUBRIFIÉ, GAZ ET LIQUIDES NEUTRES ATTRACTION FORCÉE

LAITON

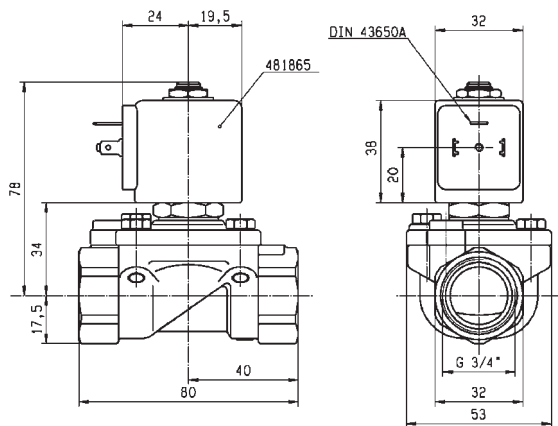
RACCORD TUYAU

FERMÉE HORS TENSION

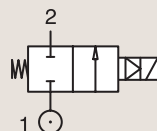

Raccord BSP	Orifice Ø mm	Facteur d'Écoulement			Pression Différentielle			Temp. Fluide		Joint	Electrovannes PARKER LUCIFER®			Puissance		Groupe Electrique	N° Schéma
		Kv l/min	KV m³/h	Qn l/min	Min bar	Max AC bar DC bar		Min °C	Max °C		Ref. Valve	Ref. Boîtier	Ref. Bobine	AC W	DC W		
1"	15	80	4.8	6000	0	16	-	-10	100	NBR	221G17	2995	481865	8	-	2.0	3445
	15	80	4.8	6000	0	16	1	-10	100	NBR	221G17	4270	481000	8	8	2.0	3445
	15	80	4.8	6000	0	16	7	-10	100	NBR	221G17	4270	486265	14	14	2.0	3445
	15	80	4.8	6000	0	16	-	-10	100	NBR	221G1710 ₁	2995	481865	8	-	2.0	3445
	15	80	4.8	6000	0	16	-	-10	100	NBR	221G1710 ₁	4270	481000	8	-	2.0	3445
	15	80	4.8	6000	0	16	7	-10	100	NBR	221G1710 ₁	4270	486265	14	14	2.0	3445
	15	80	4.8	6000	0	10	10	-10	100	FKM	221G1730 ₂₃	2995	481865	8	9	2.1	3445
	15	80	4.8	6000	0	10	10	-10	120	FKM	221G1730 ₂₃	-	492070	9	8	2.1	3445
	15	80	4.8	6000	0	10	10	-10	120	FKM	221G1730 ₂₃	-	492190	11	9	2.1	3445
	15	80	4.8	6000	0	16	-	0	100	FKM	221G27 ₃	2995	481865	8	-	2.0	3445
	15	80	4.8	6000	0	16	-	0	120	FKM	221G27 ₃	4270	481000	8	-	2.0	3445
	15	80	4.8	6000	0	20	7	0	120	FKM	221G27 ₃	4270	486265	14	14	2.0	3445
	15	80	4.8	6000	0	-	10	0	100	FKM	221G2730 ₂₃	2995	481865	-	9	2.1	3445
	15	80	4.8	6000	0	10	10	-10	65	FKM	221G2730 ₂₃	-	492070	9	8	2.1	3445
	15	80	4.8	6000	0	10	10	-10	75	FKM	221G2730 ₂₃	-	492190	11	9	2.1	3445
	25	170	10.2	14000	0	16	-	-10	100	NBR	221G21	2995	481865	8	-	2.0	3448
	25	170	10.2	14000	0	16	-	-10	100	NBR	221G21	4270	481000	8	-	2.0	3448
	25	170	10.2	14000	0	16	6	-10	100	NBR	221G21	4270	486265	14	14	2.0	3448
	25	160	9.6	14000	0	16	-	0	100	FKM	221G2106 ₃	2995	481865	8	-	2.0	3448
	25	160	9.6	14000	0	16	-	0	120	FKM	221G2106 ₃	4270	481000	8	-	2.0	3448
	25	160	9.6	14000	0	16	6	0	120	FKM	221G2106 ₃	4270	486265	14	14	2.0	3448
	25	160	9.6	14000	0	16	-	-10	100	NBR	221G2110 ₁	2995	481865	8	-	2.0	3448
	25	160	9.6	14000	0	16	-	-10	100	NBR	221G2110 ₁	4270	481000	8	-	2.0	3448
	25	160	9.6	14000	0	16	6	-10	100	NBR	221G2110 ₁	4270	486265	14	14	2.0	3448
	25	170	10.2	14000	0	-	10	-10	100	FKM	221G2130 ₂₃	2995	481865	-	9	2.1	3448
	25	170	10.2	14000	0	10	10	-25	40	FKM	221G2130 ₂₃	-	492070	9	8	2.1	3448
	25	170	10.2	14000	0	10	10	-25	40	FKM	221G2130 ₂₃	-	492190	11	9	2.1	3448
	25	170	10.2	14000	0	-	10	0	100	FKM	221G2136 ₃	2995	481865	-	9	2.0	3448
	25	170	10.2	14000	0	-	10	0	100	FKM	221G2136 ₃	4270	481000	-	8	2.0	3448

Notes:

1. Avec vis de réglage du temps de fermeture (4 positions)
2. Tension continue uniquement (ou bobine avec pont redresseur)
3. Valve uniquement compatible avec huile hydraulique, air et gaz neutres



Dans cette page	Raccord	Orifice (mm)	Kv (l/min)	Pression Diff. Max. (bar)	Temp. Fluide (°C)	Temp. Amb. (°C)
de	1"	15	80	1	-25	-10
à	1"	25	170	20	120	50



Schéma 3445



Schéma 3448

2/2

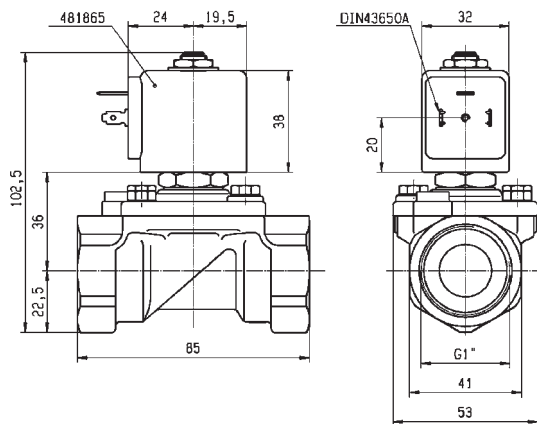
ELECTROVANNES POUR AIR SEC OU LUBRIFIÉ, GAZ ET LIQUIDES NEUTRES SERVO-COMMANDE

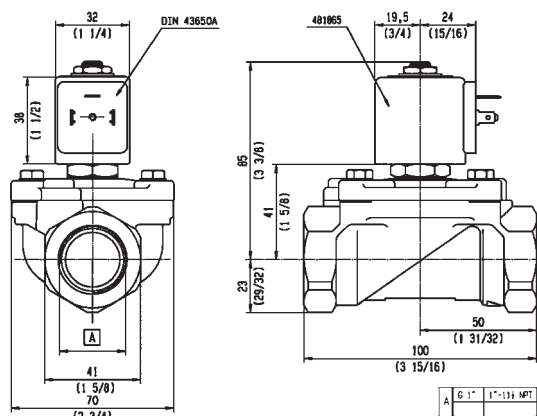

Equipement Commercial



Equipement Industriel

LAITON
RACCORD TUYAU

FERMÉE HORS TENSION

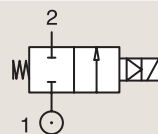

Raccord	Orifice Ø	Facteur d'Écoulement			Pression Différentielle			Temp. Fluide		Joint	Electrovannes PARKER			Puissance		Groupe Electrique	N° Schéma
					Min	Max		Min	Max		N° Commande Valve	Type de Valve	Type de Bobine	AC W	DC W		
BSP	mm	Kv l/min	KV m³/h	Qn m³/h	bar	AC bar	DC bar	°C	°C								
3/8"	13	33	2	-	0.5	16	-	-10	90	NBR	366501 ₁	PM168.1IN	ZB09	9	-	20.1/20.2	048
	13	33	2	-	0.5	-	16	-10	90	NBR	366501 ₁	PM168.1IN	ZB12	-	12	20.1/20.2	048
	13	50	3	-	0.35	15	-	-10	90	NBR	366770	PM173IN	WB4.5	4.5	-	1.3	054
	13	50	3	-	0.35	-	12	-10	90	NBR	366770	PM173IN	WB5.0	-	5	1.3	054
1/2"	13	42	2.5	-	0.5	16	-	-10	90	NBR	366511 ₁	PM168.1AN	ZB09	9	-	20.1/20.2	046
	13	42	2.5	-	0.5	-	16	-10	90	NBR	366511 ₁	PM168.1AN	ZB12	-	12	20.1/20.2	046
	13	58	3.5	-	0.35	15	-	-10	90	NBR	366775	PM173AN	WB4.5	4.5	-	1.3	053
	13	58	3.5	-	0.35	-	12	-10	90	NBR	366775	PM173AN	WB5.0	-	5	1.3	053
3/4"	20	117	7	-	0.5	16	-	-10	90	NBR	366521 ₁	PM168.1CN	ZB09	9	-	20.1/20.2	046
	20	117	7	-	0.5	-	16	-10	90	NBR	366521 ₁	PM168.1CN	ZB12	-	12	20.1/20.2	046
1"	25	133	8	-	0.5	16	-	-10	90	NBR	366531 ₁	PM168.1DN	ZB09	9	-	20.1/20.2	047
	25	133	8	-	0.5	-	16	-10	90	NBR	366531 ₁	PM168.1DN	ZB12	-	12	20.1/20.2	047

Notes:

1. Valve uniquement compatible avec air et gaz neutres



Dans cette page	Raccord	Orifice (mm)	Kv (l/min)	Pression Diff. Max. (bar)	Temp. Fluide (°C)	Temp. Amb. (°C)
de	3/8"	13	33	12	-10	-10
à	1"	25	133	16	90	50



Schéma 048



Schéma 054

Schéma 046

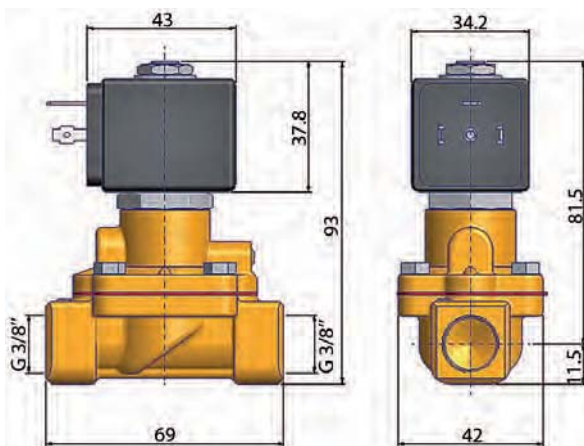

Schéma 053

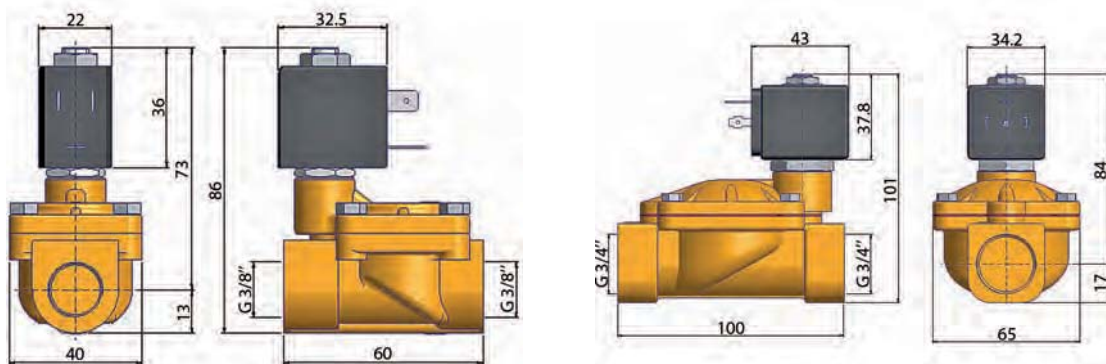
Schéma 047

2/2

ELECTROVANNES POUR AIR SEC OU LUBRIFIÉ, GAZ ET LIQUIDES NEUTRES SERVO-COMMANDE

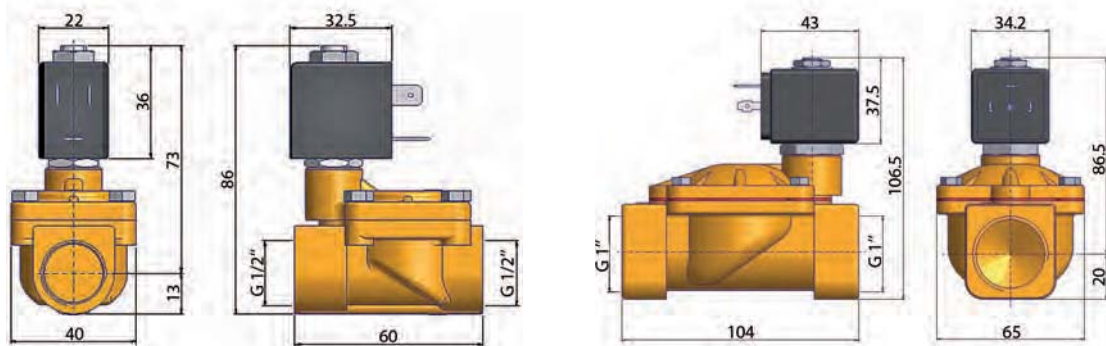
LAITON
RACCORD TUYAU

FERMÉE HORS TENSION

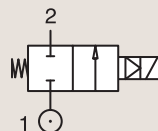

Raccord	Orifice Ø	Facteur d'Écoulement			Pression Différentielle			Temp. Fluide		Joint	Electrovannes PARKER LUCIFER®			Puissance		Groupe Electrique	N° Schéma
					Min	Max		Min	Max		Ref. Valve	Ref. Boîtier	Ref. Bobine	AC W	DC W		
BSP	mm	Kv l/min	KV m³/h	Qn l/min	bar	AC bar	DC bar	°C	°C								
1/4"	8	36	2.16	1600	0.3	40	25	-10	100	NBR	E321H11 ²³⁴	2995	481865	8	9	2.0	3523
	8	36	2.16	1600	0.3	40	30	-10	100	NBR	E321H11 ²³⁴	4270	481000	8	8	2.0	3523
	8	36	2.16	1600	0.3	40	40	-10	100	NBR	E321H11 ²³⁴	4270	486265	14	14	2.0	3523
	11	28	1.68	1800	0.2	10	3	-10	100	FKM	E321K10	2995	481865	8	9	2.0	3429
	11	28	1.68	1800	0.2	10	4	-10	100	FKM	E321K10	4270	481000	8	8	2.0	3429
	12	30	1.8	2150	0.3	10	10	-10	100	FKM	321K31	8993	481180	4	5	1.1	7093
	12	30	1.8	2150	0.3	10	7	-10	75	FKM	321K31	8993	488980	2	2.5	1.1	7093
	12	30	1.8	2150	0.3	10	10	-10	100	FKM	321K3106	8993	481180	4	5	1.1	7093
	12	30	1.8	2150	0.3	10	7	-10	75	FKM	321K3106	8993	488980	2	2.5	1.1	7093
	12	32	1.92	2150	0.3	12	12	-10	100	FKM	321K4156 ₁	2995	481865	8	9	2.1/3.0	7094
	12	32	1.92	2150	0.3	12	12	-10	120	FKM	321K4156 ₁	4270	481000	8	8	2.1/3.0	7094

Notes:

1. Avec Commande manuelle
2. Avec vis de réglage du temps de fermeture (4 positions)
3. Joint du clapet de pilotage en rubis synthétique
4. Pression différentielle min = 0.3 bar pour l'ouverture et 0 bar pour la fermeture



Schéma 7094



Dans cette page	Raccord	Orifice (mm)	Kv (l/min)	Pression Diff. Max. (bar)	Temp. Fluide (°C)	Temp. Amb. (°C)
de	1/4"	8	28	3	-10	-10
à	1/4"	12	36	40	120	50

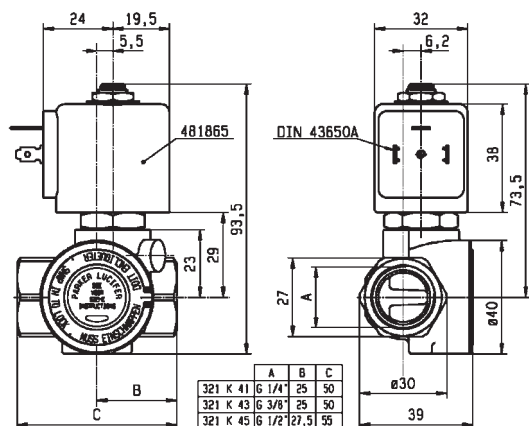

Schéma 3523



Schéma 3429

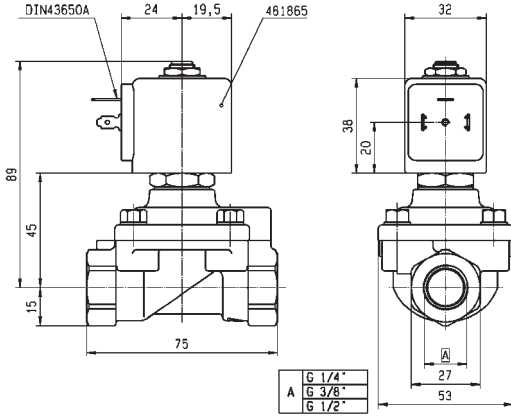

Schéma 7093

2/2

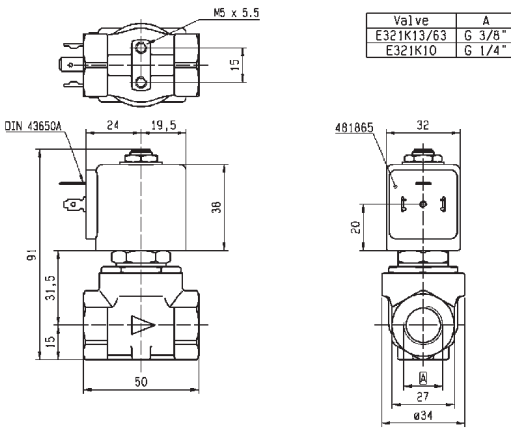
ELECTROVANNES POUR AIR SEC OU LUBRIFIÉ, GAZ ET LIQUIDES NEUTRES SERVO-COMMANDE

LAITON

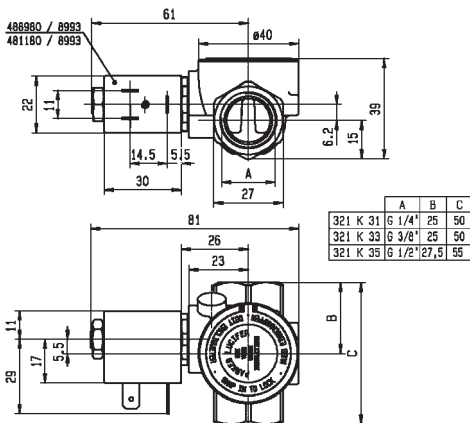
RACCORD TUYAU

FERMÉE HORS TENSION

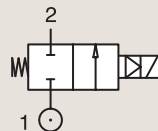

Raccord	Orifice Ø	Facteur d'Écoulement			Pression Différentielle			Temp. Fluide		Joint	Electrovannes PARKER LUCIFER®			Puissance		Groupe Electrique	N° Schéma
		BSP	mm	Kv l/min	KV m³/h	Qn l/min	Min bar	Max AC bar	Max DC bar		Min °C	Max °C	Ref. Valve	Ref. Boîtier	Ref. Bobine		
3/8"	11	50	3	2800	0.3	40	25	-10	100	NBR	E321H13 ²³⁴	2995	481865	8	9	2.0	3521
	11	50	3	2800	0.3	40	30	-10	100	NBR	E321H13 ²³⁴	4270	481000	8	8	2.0	3521
	11	50	3	2800	0.3	40	40	-10	100	NBR	E321H13 ²³⁴	4270	486265	14	14	2.0	3521
	11	36	2.16	2500	0.2	10	4	-10	100	FKM	E321K13	4270	481000	8	8	2.0	3429
	11	36	2.16	2500	0.2	10	10	-10	100	FKM	E321K13	4270	486265	14	14	2.0	3429
	11	36	2.16	2500	0.2	10	-	-10	100	NBR	E321K1314	2995	483466	8 to 11	-	2.0	3429
	11	36	2.16	2500	0.2	10	10	-10	100	NBR	E321K1314	4270	486265	14	14	2.0	3429
	12	45	2.7	3050	0.3	10	10	-10	100	FKM	321K33	8993	481180	4	5	1.1	7093
	12	45	2.7	3050	0.3	10	7	-10	75	FKM	321K33	8993	488980	2	2.5	1.1	7093
	12	45	2.7	3050	0.3	10	10	-10	100	FKM	321K3306 ⁴	8993	481180	4	5	1.1	7093
	12	45	2.7	3050	0.3	10	7	-10	75	FKM	321K3306 ⁴	8993	488980	2	2.5	1.1	7093
	12	45	2.7	3050	0.3	12	12	-10	100	FKM	321K4356 ¹	2995	481865	8	9	2.1/3.0	7094
12	45	2.7	3050	0.3	12	12	-10	120	FKM	321K4356 ¹	4270	481000	8	8	2.1/3.0	7094	

Notes:

1. Avec Commande manuelle
2. Avec vis de réglage du temps de fermeture (4 positions)
3. Joint du clapet de pilotage en rubis synthétique
4. Pression différentielle min = 0.3 bar pour l'ouverture et 0 bar pour la fermeture



Schéma 7094



Dans cette page	Raccord	Orifice (mm)	Kv (l/min)	Pression Diff. Max. (bar)	Temp. Fluide (°C)	Temp. Amb. (°C)
de	3/8"	11	36	4	-10	-10
à	3/8"	12	50	40	120	50

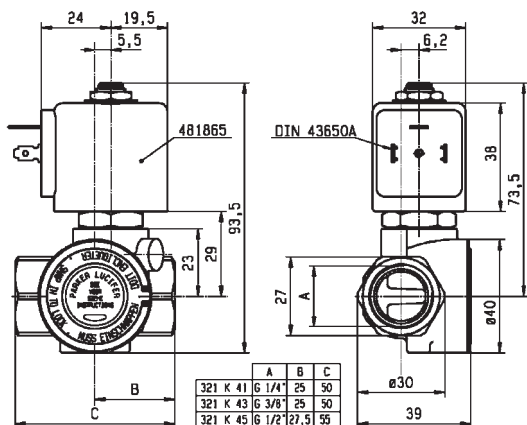

Schéma 3521



Schéma 3429

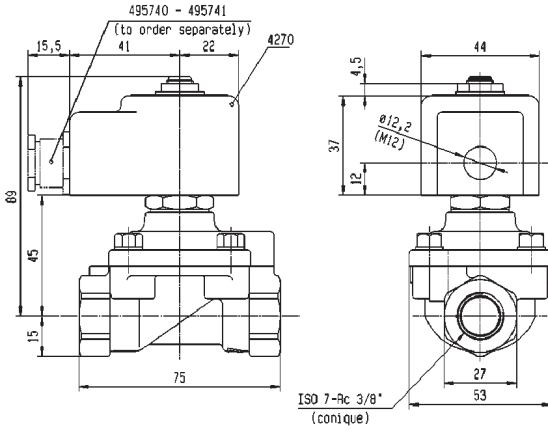

Schéma 7093

2/2

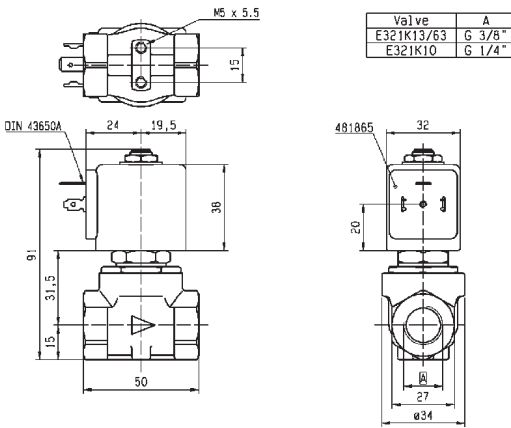
ELECTROVANNES POUR AIR SEC OU LUBRIFIÉ, GAZ ET LIQUIDES NEUTRES SERVO-COMMANDE

LAITON
RACCORD TUYAU

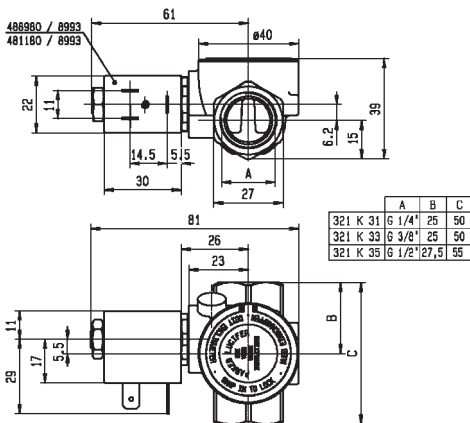
FERMÉE HORS TENSION

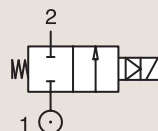

Raccord BSP	Orifice Ø mm	Facteur d'Écoulement			Pression Différentielle			Temp. Fluide		Joint	Electrovannes PARKER LUCIFER®			IS	Puissance		Groupe Electrique	N° Schéma
		Kv l/min	KV m³/h	Qn l/min	Min bar	Max AC bar	DC bar	Min °C	Max °C		Ref. Valve	Ref. Boîtier	Ref. Bobine		AC W	DC W		
1/2"	11	36	2.16	2500	0.2	10	3	-10	100	NBR	E321K15	2995	481865	8	9	2.0	3427	
	11	36	2.16	2500	0.2	10	10	-10	120	NBR	E321K15	4270	486265	14	14	2.0	3427	
	11	36	2.16	2500	0.2	10	3	-10	100	FKM	E321K1514	2995	481865	8	9	2.0	3427	
	11	36	2.16	2500	0.2	10	4	-10	120	FKM	E321K1514	-	483371	8	8	2.0	3427	
	11	36	2.16	2500	0.2	10	3	-10	100	NBR	E321K25	2995	481865	8	9	2.0	3427	
	11	36	2.16	2500	0.2	10	4	-10	120	NBR	E321K25	-	492070	9	8	2.0	3427	
	12	50	3	3400	0.3	10	10	-10	100	NBR	321K35	8993	481180	4	5	1.1	7093	
	12	50	3	3400	0.3	10	7	-10	75	NBR	321K35	8993	488980	2	2.5	1.1	7093	
	12	50	3	3400	0.3	10	10	-10	100	FKM	321K3506	8993	481180	4	5	1.1	7093	
	12	50	3	3400	0.3	10	7	-10	75	FKM	321K3506	8993	488980	2	2.5	1.1	7093	
	15	60	3.6	3150	0.3	-	10	-10	100	NBR	321H1590	2995	483580.01	*	-	0.5 to 3	7.0/8.0	3978
	15	60	3.6	3150	0.3	-	10	-10	100	NBR	321H1590	-	488660.01	*	-	0.3 to 3	7.0/8.0	3978
	15	60	3.6	3150	0.3	-	10	-10	100	NBR	321H1590	-	495910	*	-	0.3 to 3	7.0/8.0	3978
	15	60	3.6	3150	1.5	40	40	-10	50	PUR	321H35 ₃	2995	481865	8	9	2.1	3522	
	15	60	3.6	3150	1.5	40	40	-10	50	PUR	321H35 ₃	4270	481000	8	8	2.1	3522	
	15	60	3.6	3150	0.3	40	25	-10	100	NBR	E321H15 ₂₃₄	2995	481865	8	9	2.0	3522	
	15	60	3.6	3150	0.3	40	30	-10	100	NBR	E321H15 ₂₃₄	4270	481000	8	8	2.0	3522	
	15	60	3.6	3150	0.3	40	40	-10	100	NBR	E321H15 ₂₃₄	4270	486265	14	14	2.0	3522	

Notes:

1. Avec Commande manuelle
2. Avec vis de réglage du temps de fermeture (4 positions)
3. Joint du clapet de pilotage en rubis synthétique
4. Pression différentielle min = 0.3 bar pour l'ouverture et 0 bar pour la fermeture



Schéma 3522



Dans cette page	Raccord	Orifice (mm)	Kv (l/min)	Pression Diff. Max. (bar)	Temp. Fluide (°C)	Temp. Amb. (°C)
de	1/2"	11	36	3	-10	-10
à	1/2"	15	60	40	120	50

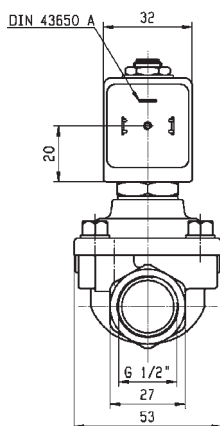
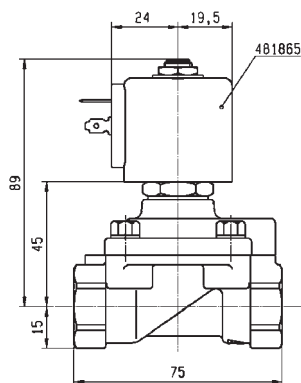

Schéma 3427



Schéma 7093

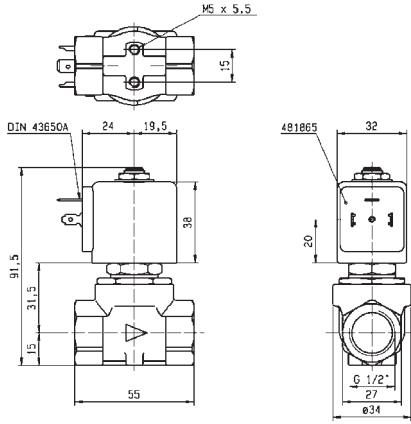

Schéma 3978

2/2

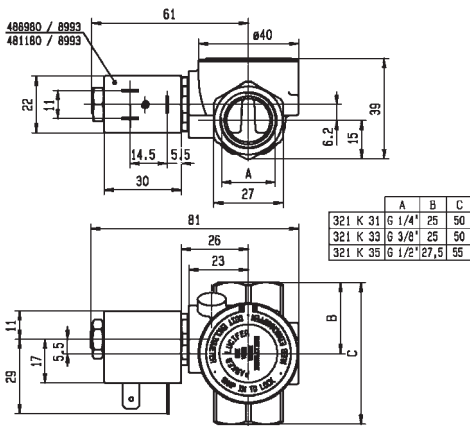
ELECTROVANNES POUR AIR SEC OU LUBRIFIÉ,
GAZ ET LIQUIDES NEUTRES
SERVO-COMMANDE

LAITON

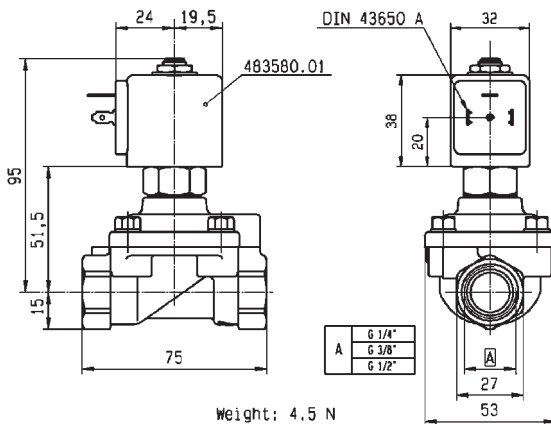
RACCORD TUYAU

FERMÉE HORS TENSION

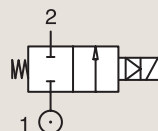

Raccord	Orifice Ø	Facteur d'Écoulement			Pression Différentielle			Temp. Fluide		Joint	Electrovannes PARKER LUCIFER®			Puissance		Groupe Electrique	N° Schéma
		Kv l/min	KV m³/h	Qn l/min	Min bar	Max AC bar	DC bar	Min °C	Max °C		Ref. Valve	Ref. Boîtier	Ref. Bobine	AC W	DC W		
3/4"	15	100	6	3550	1.5	40	40	-10	50	PUR	321H36 ₁	2995	481865	8	9	2.1	3696
	15	100	6	3550	1.5	40	40	-10	50	PUR	321H36 ₁	4270	481000	8	8	2.1	3696
	18	100	6	9400	0.3	10	10	-10	100	NBR	321K36	8993	481180	4	5	1.1	7097
	18	100	6	9400	0.3	10	7	-10	75	NBR	321K36	8993	488980	2	2.5	1.1	7097
	18	100	6	9400	0.3	10	10	-10	100	FKM	321K3606	8993	481180	4	5	1.1	7097
	18	100	6	9400	0.3	10	7	-10	75	FKM	321K3606	8993	488980	2	2.5	1.1	7097
	20	135	8.1	9500	0.3	16	16	-10	100	NBR	E321G36	2995	481865	8	9	2.0	3442
	20	135	8.1	9500	0.3	16	16	-10	100	NBR	E321G36	4270	481000	8	8	2.0	3442
	20	135	8.1	9500	0.3	16	16	-10	100	FKM	E321G3606	2995	481865	8	9	2.0/14.1	3442
	20	135	8.1	9500	0.3	16	16	-10	120	FKM	E321G3606	4270	481000	8	8	2.0/14.1	3442
20	135	8.1	9500	0.3	16	16	-10	120	FKM	E321G3606	4270	486265	14	14	2.0/14.1	3442	

Notes:

1. Joint du clapet de pilotage en rubis synthétique



Dans cette page	Raccord	Orifice (mm)	Kv (l/min)	Pression Diff. Max. (bar)	Temp. Fluide (°C)	Temp. Amb. (°C)
de	3/4"	15	100	7	-10	-10
à	3/4"	20	135	40	120	50



Schéma 3696



Schéma 7097

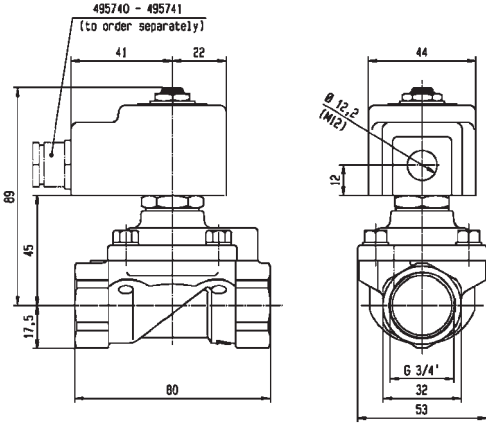

RACCORD	Ø	C	D	E	F	G	H
321/322/E321G36	BSP 3/4"	121	50	23	54	41	100 70
321/322/E321G37	OSP 1"	121	50	23	54	41	100 70
321/322/E321G38	OSP 1 1/4"	137	55	33	60	50	110 70
321/322/E321G39	BSP 1 1/2"	144	75	33	87	60	140 99
321G2956/G2967	DNF 1 7/8"	144	75	33	87	60	140 99
U321A/G22G40...	BSP 2"	158.5	80	41.5	73	75	150 99

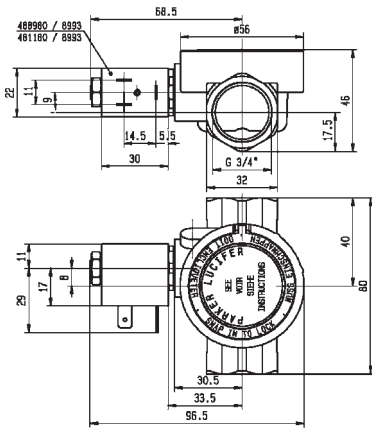
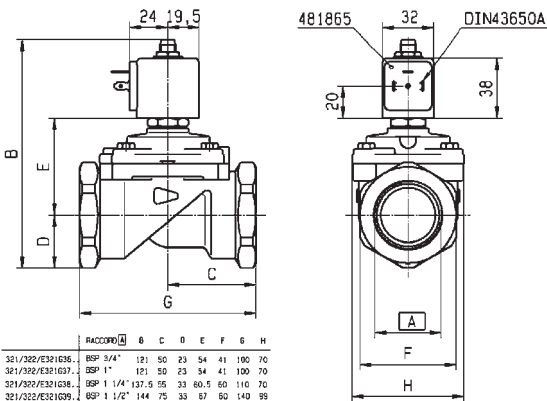

Schéma 3442

2/2

ELECTROVANNES POUR AIR SEC OU LUBRIFIÉ, GAZ ET LIQUIDES NEUTRES SERVO-COMMANDE

LAITON

RACCORD TUYAU

FERMÉE HORS TENSION

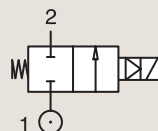

Raccord BSP	Orifice Ø mm	Facteur d'Écoulement			Pression Différentielle			Temp. Fluide		Joint	Electrovannes PARKER LUCIFER®			IS	Puissance		Groupe Electrique	N° Schéma
		Kv l/min	KV m³/h	Qn l/min	Min bar	Max AC bar	DC bar	Min °C	Max °C		Ref. Valve	Ref. Boîtier	Ref. Bobine		AC W	DC W		
1"	18	110	6.6	10150	0.3	10	10	-10	100	NBR	321K37	8993	481180		4	5	1.1	7098
	18	110	6.6	10150	0.3	10	7	-10	75	NBR	321K37	8993	488980		2	2.5	1.1	7098
	18	110	6.6	10150	0.3	10	10	-10	100	FKM	321K3706	8993	481180		4	5	1.1	7098
	18	110	6.6	10150	0.3	10	7	-10	75	FKM	321K3706	8993	488980		2	2.5	1.1	7098
	25	185	11.1	14100	0.3	-	10	-10	75	FKM	321G3790	2995	483580.01	*	-	0.5 to 3	7.0	3442
	25	185	11.1	14100	0.3	-	10	-10	75	FKM	321G3790	-	488660.01	*	-	0.3 to 3	7.0	3442
	25	185	11.1	14100	0.3	-	10	-10	75	FKM	321G3790	-	495910	*	-	0.3 to 3	7.0	3442
	25	180	10.8	14000	0.3	16	16	-10	100	NBR	E321G37	2995	481865		8	9	2.0	3442
	25	180	10.8	14000	0.3	16	16	-10	100	NBR	E321G37	4270	481000		8	8	2.0	3442
	25	180	10.8	14000	0.3	16	16	-10	100	FKM	E321G3706	2995	481865		8	9	2.0/14.1	3442
	25	180	10.8	14000	0.3	16	16	-10	120	FKM	E321G3706	4270	481000		8	8	2.0/14.1	3442
	25	180	10.8	14000	0.3	16	16	-10	120	FKM	E321G3706	4270	486265		14	14	2.0/14.1	3442
	28	270	16.2	18000	0.3	16	16	-10	100	NBR	E321G38	2995	481865		8	9	2.0	3442
	28	270	16.2	18000	0.3	16	16	-10	100	NBR	E321G38	4270	481000		8	8	2.0	3442
	28	270	16.2	18000	0.3	16	16	-10	100	FKM	E321G3806	2995	481865		8	9	2.0	3442
	28	270	16.2	18000	0.3	16	16	-10	120	FKM	E321G3806	4270	481000		8	8	2.0	3442
28	270	16.2	18000	0.3	16	16	-10	100	FKM	E321G3806	4270	486265		14	14	2.0	3442	



Dans cette page	Raccord	Orifice (mm)	Kv (l/min)	Pression Diff. Max. (bar)	Temp. Fluide (°C)	Temp. Amb. (°C)
de	1"	18	110	7	-10	-10
à	1"	28	270	16	120	50



Schéma 7098



Schéma 3442

2/2

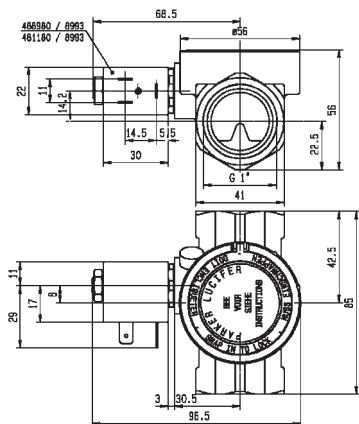
ELECTROVANNES POUR AIR SEC OU LUBRIFIÉ, GAZ ET LIQUIDES NEUTRES SERVO-COMMANDE

LAITON

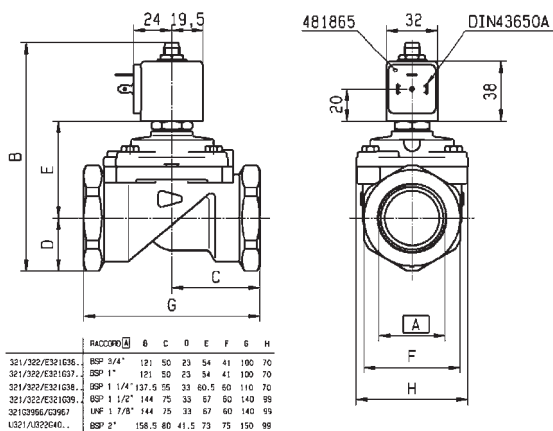
RACCORD TUYAU

FERMÉE HORS TENSION

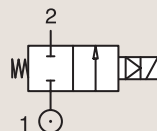

Raccord BSP	Orifice Ø mm	Facteur d'Écoulement			Pression Différentielle			Temp. Fluide		Joint	Electrovannes PARKER LUCIFER®			IS	Puissance		Groupe Electrique	N° Schéma
		Kv l/min	KV m³/h	Qn l/min	Min bar	Max AC bar	DC bar	Min °C	Max °C		Ref. Valve	Ref. Boîtier	Ref. Bobine		AC W	DC W		
1 1/2"	40	425	25.5	31500	0.5	-	10	-10	75	NBR	321G3990	2995	483580.01	*	-	0.5 to 3	7.0	8113
	40	425	25.5	31500	0.5	-	10	-10	75	NBR	321G3990	-	488660.01	*	-	0.3 to 3	7.0	8113
	40	425	25.5	31500	0.5	-	10	-10	75	NBR	321G3990	-	495910	*	-	0.3 to 3	7.0	8113
	40	420	25.2	31500	0.3	16	7	-10	100	NBR	E321G39 ₃	2995	481865		8	9	2.0	3442
	40	420	25.2	31500	0.3	16	8.5	-10	100	NBR	E321G39 ₃	4270	481000		8	8	2.0	3442
	40	420	25.2	31500	0.3	16	7	-10	100	FKM	E321G3906	2995	481865		8	9	2.0	3442
	40	420	25.2	31500	0.3	16	8.5	-10	120	FKM	E321G3906	4270	481000		8	8	2.0	3442
	40	420	25.2	31500	0.3	16	16	-10	100	FKM	E321G3906	4270	486265		14	14	2.0	3442
2"	40	540	32.4	38100	0.5	-	10	-10	75	FKM	321G4090	2995	483580.01	*	-	0.5 to 3	7.0	8113
	40	540	32.4	38100	0.5	-	10	-10	75	FKM	321G4090	-	488660.01	*	-	0.3 to 3	7.0	8113
	40	540	32.4	38100	0.5	-	10	-10	75	FKM	321G4090	-	495910	*	-	0.3 to 3	7.0	8113
	40	540	32.4	40000	0.3	16	7	-10	100	NBR	E321G40 ₃	2995	481865		8	9	2.0	3442
	40	540	32.4	40000	0.3	16	8.5	-10	100	NBR	E321G40 ₃	4270	481000		8	8	2.0	3442
	40	540	32.4	40000	0.3	16	7	-10	100	FKM	E321G4006	2995	481865		8	9	2.0	3442
	40	540	32.4	40000	0.3	16	8.5	-10	120	FKM	E321G4006	4270	481000		8	8	2.0	3442
	40	540	32.4	40000	0.3	16	7	-10	120	FKM	E321G4006	4270	486265		14	14	2.0	3442

Notes:

1. Avec Commande manuelle
2. Avec vis de réglage du temps de fermeture (4 positions)
3. Joint du clapet de pilotage en rubis synthétique
4. Pression différentielle min = 0.3 bar pour l'ouverture et 0 bar pour la fermeture



Dans cette page	Raccord	Orifice (mm)	Kv (l/min)	Pression Diff. Max. (bar)	Temp. Fluide (°C)	Temp. Amb. (°C)
de	1 1/2"	40	420	7	-10	-10
à	2"	40	540	16	120	50



Schéma 8113



Schéma 3442

2/2

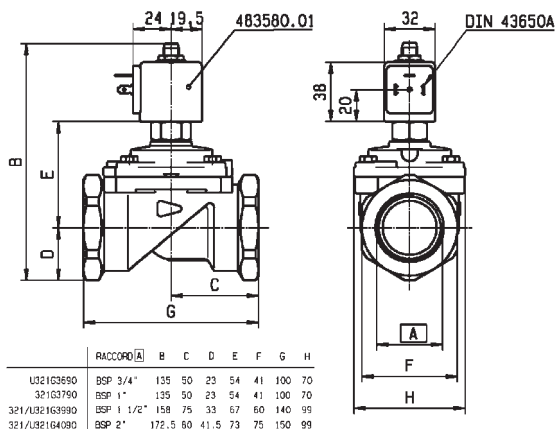
ELECTROVANNES POUR AIR SEC OU LUBRIFIÉ, GAZ ET LIQUIDES NEUTRES SERVO-COMMANDE

LAITON

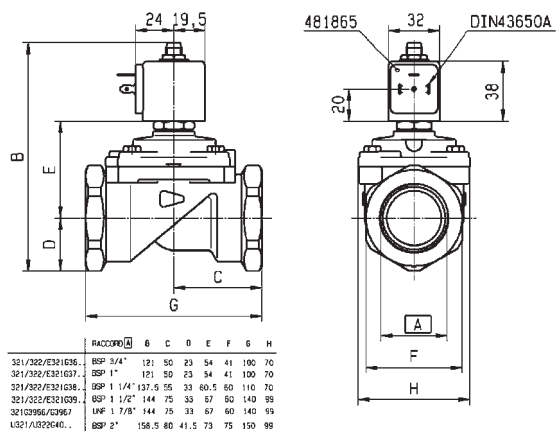
RACCORD TUYAU

OUVERTE HORS TENSION

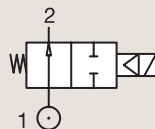

Raccord	Orifice Ø	Facteur d'Écoulement			Pression Différentielle			Temp. Fluide		Joint	Electrovannes PARKER			Puissance		Groupe Electrique	N° Schéma
		Kv l/min	KV m³/h	Qn m³/h	Min bar	Max AC bar	Max DC bar	Min °C	Max °C		N° Commande Valve	Type de Valve	Type de Bobine	AC W	DC W		
3/8"	13	33	2	-	0.5	-	16	-10	90	NBR	366601 ₁	PM169.1IN	ZB16	-	12	20.1/20.2	052
	13	33	2	-	0.5	16	-	-10	90	NBR	366601 ₁	PM169.1IN	ZH14	9	-	20.1/20.2	052
1/2"	13	42	2.5	-	0.5	-	16	-10	90	NBR	366606 ₁	PM169.1AN	ZB16	-	12	20.1/20.2	049
	13	42	2.5	-	0.5	16	-	-10	90	NBR	366606 ₁	PM169.1AN	ZH14	9	-	20.1/20.2	049
3/4"	20	117	7	-	0.5	-	16	-10	90	NBR	366611 ₁	PM169.1CN	ZB16	-	12	20.1/20.2	050
	20	117	7	-	0.5	16	-	-10	90	NBR	366611 ₁	PM169.1CN	ZH14	9	-	20.1/20.2	050
1"	25	133	8	-	0.5	-	16	-10	90	NBR	366616 ₁	PM169.1DN	ZB16	-	12	20.1/20.2	051
	25	133	8	-	0.5	16	-	-10	90	NBR	366616 ₁	PM169.1DN	ZH14	9	-	20.1/20.2	051

Notes:

1.Valve uniquement compatible avec air et gaz neutres



Schéma 051



Dans cette page	Raccord	Orifice (mm)	Kv (l/min)	Pression Diff. Max. (bar)	Temp. Fluide (°C)	Temp. Amb. (°C)
de	3/8"	13	33	16	-10	-10
à	1"	25	133	16	90	50

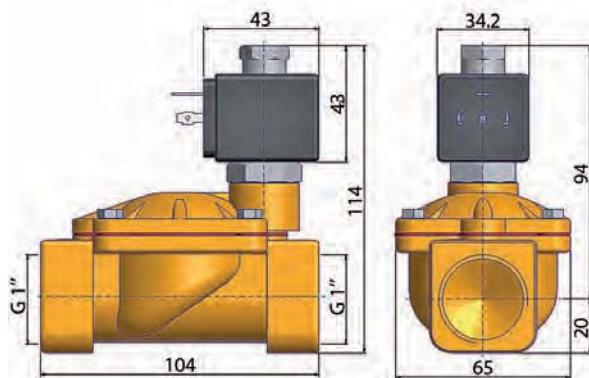

Schéma 052



Schéma 049

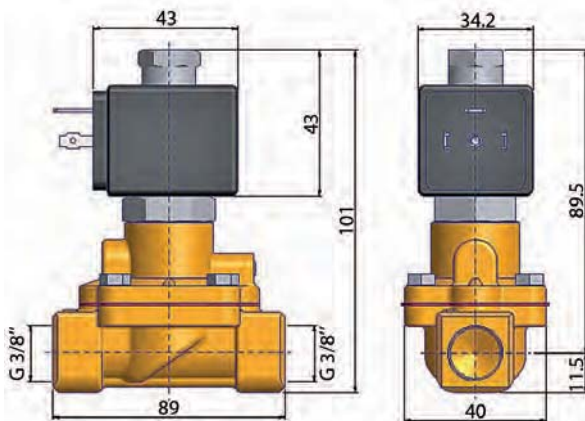

Schéma 050

2/2

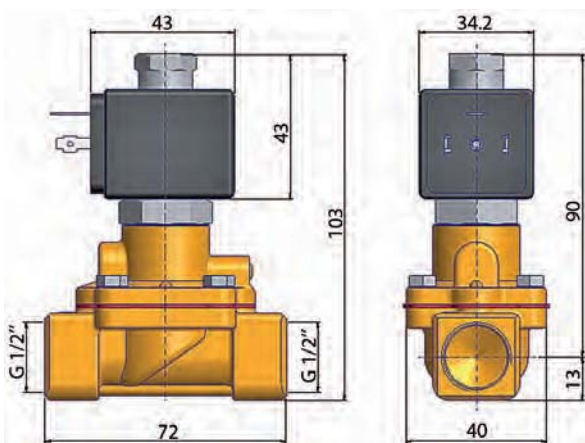
ELECTROVANNES POUR AIR SEC OU LUBRIFIÉ, GAZ ET LIQUIDES NEUTRES SERVO-COMMANDE

LAITON

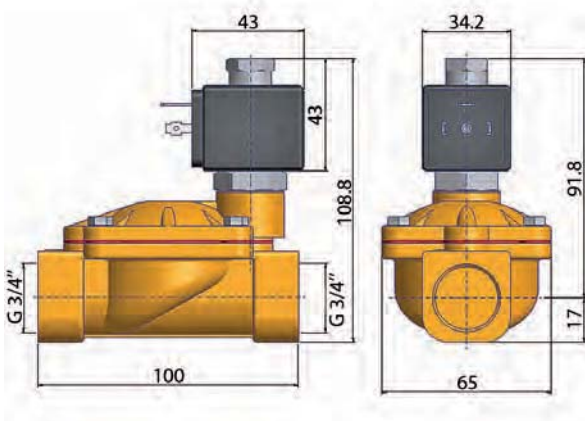
RACCORD TUYAU

OUVERTE HORS TENSION

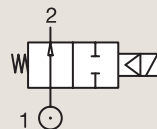

Raccord BSP	Orifice Ø mm	Facteur d'Écoulement			Pression Différentielle			Temp. Fluide		Joint	Electrovannes PARKER LUCIFER®			Puissance		Groupe Électrique	N° Schéma
					Min bar	Max		Min °C	Max °C		Ref. Valve	Ref. Boîtier	Ref. Bobine	AC W	DC W		
						AC bar	DC bar										
1/4"	8	36	2.16	1600	0.3	40	25	-10	100	NBR	322H71 ₁₂₃	2995	481865	8	9	2.0	3523
	8	36	2.16	1600	0.3	40	30	-10	100	NBR	322H71 ₁₂₃	4270	481000	8	8	2.0	3523
	8	36	2.16	1600	0.3	40	40	-10	100	NBR	322H71 ₁₂₃	4270	486265	14	14	2.0	3523
	8	36	2.16	-	0.3	40	40	-10	100	FKM	322H7106 ₁₂₃	2995	481865	8	9	2.0/14.1	3523
	8	36	2.16	-	0.3	40	40	-10	120	FKM	322H7106 ₁₂₃	4270	481000	8	8	2.0/14.1	3523
	8	36	2.16	-	0.3	40	40	-10	140	FKM	322H7106 ₁₂₃	4270	486265	14	14	2.0/14.1	3523
3/8"	11	50	3	3240	0.3	40	40	-10	75	NBR	322H73 ₁₂₃	2995	481865	8	9	2.0	3523
	11	50	3	3240	0.3	40	40	-10	75	NBR	322H73 ₁₂₃	4270	481000	8	8	2.0	3523
	11	50	3	3240	0.3	40	40	-10	75	NBR	322H73 ₁₂₃	4270	486265	14	14	2.0	3523
	11	50	3	-	0.3	40	40	-10	100	FKM	322H7306 ₁₂₃	2995	481865	8	9	2.0/14.1	3523
	11	50	3	-	0.3	40	40	-10	100	FKM	322H7306 ₁₂₃	4270	481000	8	8	2.0/14.1	3523
	11	50	3	-	0.3	40	40	-10	140	FKM	322H7306 ₁₂₃	4270	486265	14	14	2.0/14.1	3523
1/2"	15	60	3.6	3890	0.3	15	15	-10	100	NBR	322G75	2995	481865	8	9	2.1	3522
	15	60	3.6	3890	0.3	15	15	-10	100	NBR	322G75	4270	481000	8	8	2.1	3522
	15	60	3.6	3890	0.3	20	20	-10	100	FKM	322G7506 ₃	2995	481865	8	9	2.0	3522
	15	60	3.6	3890	0.3	20	20	-10	100	FKM	322G7506 ₃	4270	481000	8	8	2.0	3522
	15	60	3.6	3890	0.3	20	20	-10	100	FKM	322G7506 ₃	4270	486265	14	14	2.0	3522
	15	60	3.6	3150	1.5	40	40	-10	50	PUR	322H35	2995	481865	8	9	2.1	7569
	15	60	3.6	3150	1.5	40	40	-10	50	PUR	322H35	4270	481000	8	8	2.1	7569
	15	60	3.6	3890	0.3	40	40	-10	100	NBR	322H75 ₁₂₃	2995	481865	8	9	2.0	3522
	15	60	3.6	3890	0.3	40	40	-10	100	NBR	322H75 ₁₂₃	4270	481000	8	8	2.0	3522
	15	60	3.6	3890	0.3	40	40	-10	100	NBR	322H75 ₁₂₃	4270	486265	14	14	2.0	3522
	15	60	3.6	-	0.3	40	40	-10	100	FKM	322H7506 ₁₂₃	2995	481865	8	9	2.0/14.1	3522
	15	60	3.6	-	0.3	40	40	-10	120	FKM	322H7506 ₁₂₃	4270	481000	8	8	2.0/14.1	3522
	15	60	3.6	-	0.3	40	40	-10	140	FKM	322H7506 ₁₂₃	4270	486265	14	14	2.0/14.1	3522

Notes:

1. Avec vis de réglage du temps de fermeture. (4 positions)
2. Joint du clapet de pilotage en rubis synthétique
3. Pression différentielle min = 0.3 bar pour l'ouverture et 0 bar pour la fermeture



Dans cette page	Raccord	Orifice (mm)	Kv (l/min)	Pression Diff. Max. (bar)	Temp. Fluide (°C)	Temp. Amb. (°C)
de	1/4"	8	36	15	-10	-10
à	1/2"	15	60	40	140	50



Schéma 3523



Schéma 3522

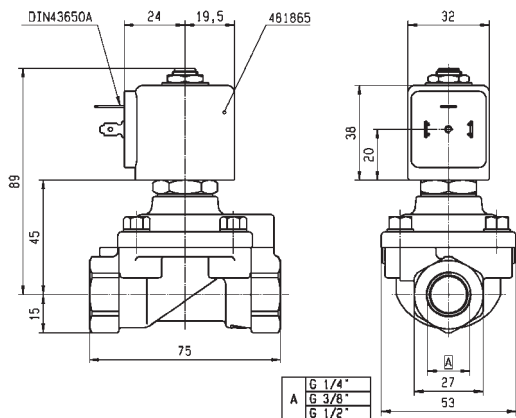

Schéma 7569

2/2

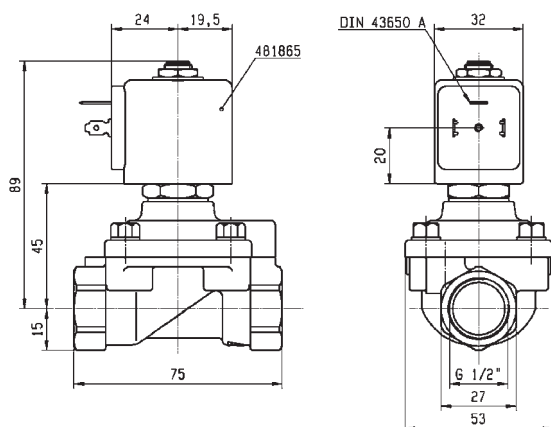
ELECTROVANNES POUR AIR SEC OU LUBRIFIÉ, GAZ ET LIQUIDES NEUTRES SERVO-COMMANDE

LAITON

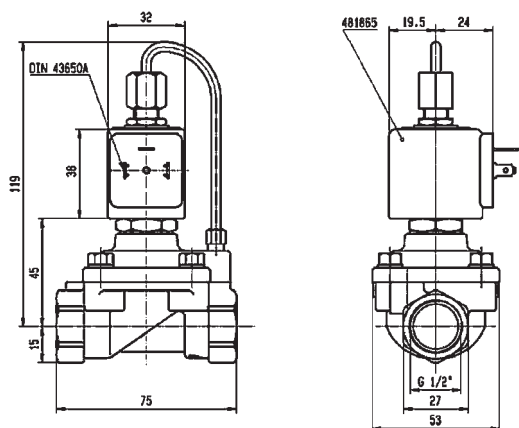
RACCORD TUYAU

OUVERTE HORS TENSION

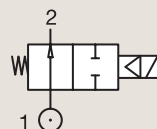

Raccord	Orifice Ø	Facteur d'Écoulement			Pression Différentielle			Temp. Fluide		Joint	Electrovannes PARKER LUCIFER®			Puissance		Groupe Électrique	N° Schéma
					Min	Max		Min	Max		Ref. Valve	Ref. Boîtier	Ref. Bobine	AC W	DC W		
BSP	mm	Kv l/min	KV m³/h	Qn l/min	bar	AC bar	DC bar	Min °C	Max °C								
3/4"	15	-	-	3550	1.5	40	40	-10	50	PUR	322H36 ₁	2995	481865	8	9	2.1	7570
	15	-	-	3550	1.5	40	40	-10	50	PUR	322H36 ₁	4270	481000	8	8	2.1	7570
	20	135	8.1	9500	0.3	16	16	-10	100	NBR	322G36	2995	481865	8	9	2.1	3442
	20	135	8.1	9500	0.3	16	16	-10	100	NBR	322G36	4270	481000	8	8	2.1	3442
	20	135	8.1	9500	0.3	16	16	-10	100	FKM	322G3606	2995	481865	8	9	2.1	3442
	20	135	8.1	9500	0.3	16	16	-10	120	FKM	322G3606	4270	481000	8	8	2.1	3442
1"	25	180	10.8	14000	0.3	16	16	-10	100	NBR	322G37	2995	481865	8	9	2.1	3442
	25	180	10.8	14000	0.3	16	16	-10	100	NBR	322G37	4270	481000	8	8	2.1	3442
	25	180	10.8	14000	0.3	16	16	-10	100	FKM	322G3706	2995	481865	8	9	2.1	3442
	25	180	10.8	14000	0.3	16	16	-10	120	FKM	322G3706	4270	481000	8	8	2.1	3442
1 1/4"	28	270	16.2	18000	0.3	16	16	-10	100	NBR	322G38	2995	481865	8	9	2.1	3442
	28	270	16.2	18000	0.3	16	16	-10	100	NBR	322G38	4270	481000	8	8	2.1	3442
	28	270	16.2	18000	0.3	16	16	-10	100	FKM	322G3806	2995	481865	8	9	2.1	3442
	28	270	16.2	18000	0.3	16	16	-10	120	FKM	322G3806	4270	481000	8	8	2.1	3442
1 1/2"	40	420	25.2	31500	0.3	12	12	-10	100	NBR	322G39	2995	481865	8	9	2.1	3442
	40	420	25.2	31500	0.3	12	12	-10	100	NBR	322G39	4270	481000	8	8	2.1	3442
	40	420	25.2	31500	0.3	12	12	-10	100	FKM	322G3906	2995	481865	8	9	2.1	3442
	40	420	25.2	31500	0.3	12	12	-10	100	FKM	322G3906	4270	481000	8	8	2.1	3442
2"	40	540	32.4	40000	0.3	12	12	-10	100	NBR	322G40	2995	481865	8	9	2.1	3442
	40	540	32.4	40000	0.3	12	12	-10	100	NBR	322G40	4270	481000	8	8	2.1	3442
	40	540	32.4	40000	0.3	12	12	-10	100	FKM	322G4006	2995	481865	8	9	2.1	3442
	40	540	32.4	40000	0.3	12	12	-10	120	FKM	322G4006	4270	481000	8	8	2.1	3442

Notes:

1. Pression différentielle min = 1.5 bar pour l'ouverture et 0.3 bar pour la fermeture



Dans cette page	Raccord	Orifice (mm)	Kv (l/min)	Pression Diff. Max. (bar)	Temp. Fluide (°C)	Temp. Amb. (°C)
de	3/4"	15	135	12	-10	-10
à	2"	40	540	40	120	50



Schéma 7570



	RACCORD	G	C	D	E	F	G	H
321/322/E321G36	BSP 3/4"	121	50	23	54	41	100	70
321/332/E321G37	BSP 1"	121	50	23	54	41	100	70
321/330/E321G38	BSP 1 1/4"	137.5	55	33	60.5	60	110	70
321/322/E321G39	BSP 1 1/2"	144	75	33	67	80	140	99
321/326/E321G37	NPT 1 7/8"	144	75	33	67	80	140	99
U321/AU320G40	BSP 2"	156.5	80	41.5	73	75	150	99

Schéma 3442

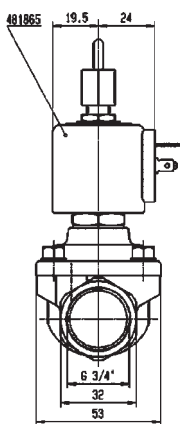
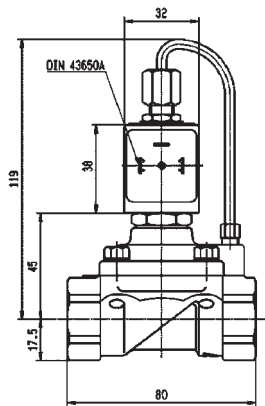
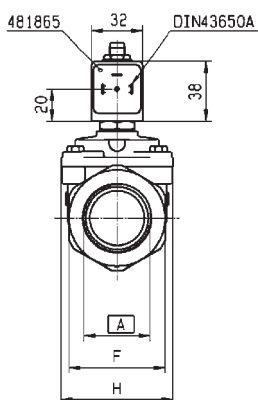
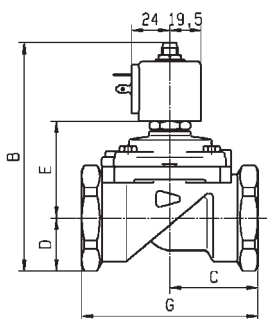
2/2

ELECTROVANNES POUR AIR SEC OU LUBRIFIÉ, GAZ ET LIQUIDES NEUTRES SERVO-COMMANDE

LAITON

RACCORD TUYAU

COMMANDE PAR IMPULSION

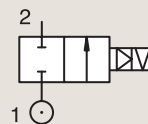

Raccord BSP	Orifice Ø mm	Facteur d'Écoulement			Pression Différentielle			Temp. Fluide		Joint	Electrovannes PARKER LUCIFER®			Puissance		Groupe Electrique	N° Schéma
		Kv l/min	KV m³/h	Qn l/min	Min bar	Max AC bar DC bar		Min °C	Max °C		Ref. Valve	Ref. Boîtier	Ref. Bobine	AC W	DC W		
1/4"	12	32	1.92	2150	0.3	12	-	-10	100	FKM	325K4106	4269	484990	11	-	4.0	7094
	12	32	1.92	2150	0.3	-	12	-10	100	FKM	325K4106	4269	485400	-	13	4.0	7094
3/8"	12	45	2.7	3050	0.3	12	-	-10	100	FKM	325K4306	4269	484990	11	-	4.0	7094
	12	45	2.7	3050	0.3	-	12	-10	100	FKM	325K4306	4269	485400	-	13	4.0	7094
1/2"	12	50	3	3400	0.3	12	-	-10	100	FKM	325K4506	4269	484990	11	-	4.0	7094
	12	50	3	3400	0.3	-	12	-10	100	FKM	325K4506	4269	485400	-	13	4.0	7094
3/4"	18	100	6	9400	0.3	12	-	-10	100	FKM	325K4606	4269	484990	11	-	4.0	7099
	18	100	6	9400	0.3	-	12	-10	100	FKM	325K4606	4269	485400	-	13	4.0	7099
1"	18	110	6.6	10150	0.3	12	-	-10	100	FKM	325K4706	4269	484990	11	-	4.0	7100
	18	110	6.6	10150	0.3	-	12	-10	100	FKM	325K4706	4269	485400	-	13	4.0	7100



Dans cette page	Raccord	Orifice (mm)	Kv (l/min)	Pression Diff. Max. (bar)	Temp. Fluide (°C)	Temp. Amb. (°C)
de	1/4"	12	32	12	-10	-10
à	1"	18	110	12	100	50



Schéma 7094



Schéma 7099

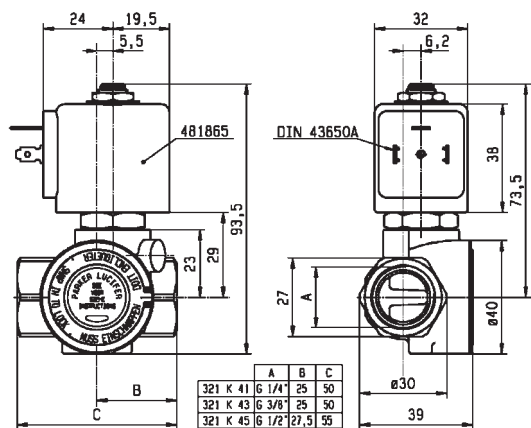

Schéma 7100

2/2

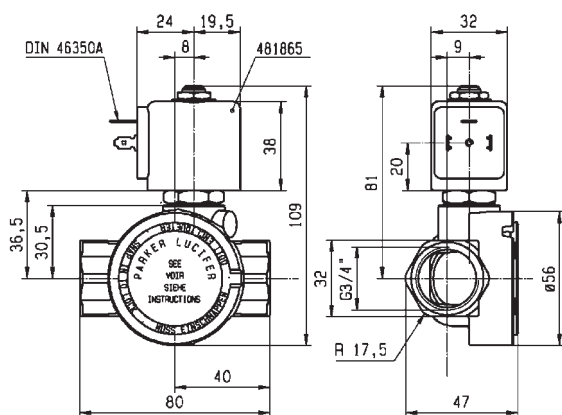
ELECTROVANNES POUR AIR SEC OU LUBRIFIÉ, GAZ ET LIQUIDES NEUTRES SERVO-COMMANDE

LAITON

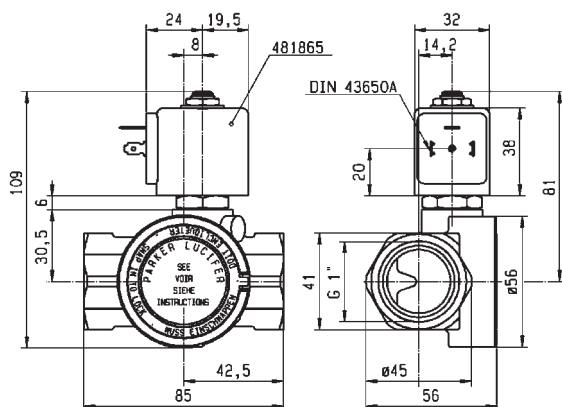
MONTAGE SUR EMBASE

FERMÉE HORS TENSION

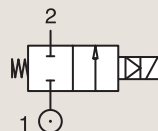

Raccord	Orifice Ø	Facteur d'Écoulement			Pression Différentielle			Temp. Fluide		Joint	Electrovannes PARKER LUCIFER®			Puissance		Groupe Electrique	N° Schéma
					Min bar	Max		Min °C	Max °C		Ref. Valve	Ref. Boîtier	Ref. Bobine	AC W	DC W		
						AC bar	DC bar										
SB	14	-	-	2100	1.5	40	40	-10	50	PUR	321F35	2995	481865	8	9	2.0	3520
	14	-	-	2100	1.5	40	40	-10	50	PUR	321F35	2995	492425	14	14	2.0	3520
	14	-	-	2100	0	13	13	-10	50	PUR	421F35	2995	481865	8	9	2.1	3520
	14	45	2.7	2100	0.3	40	25	-10	100	NBR	E321F32 ₂	2995	481865	8	9	2.0	3520
	14	45	2.7	2100	0.3	40	30	-10	100	NBR	E321F32 ₂	4270	481000	8	8	2.0	3520
	14	45	2.7	2100	0.3	40	40	-10	100	NBR	E321F32 ₂	4270	486265	14	14	2.0	3520
	14	45	2.7	-	0.3	40	25	-10	100	FKM	E321F3202 ₁₂₃₄	2995	481865	8	9	2.0	3520
	14	45	2.7	-	0.3	40	30	-10	120	FKM	E321F3202 ₁₂₃₄	4270	481000	8	8	2.0	3520
	14	45	2.7	-	0.3	40	40	-10	140	FKM	E321F3202 ₁₂₃₄	4270	486265	14	14	2.0	3520

Notes:

- Avec vis de réglage du temps de fermeture (4 positions)
- Joint du clapet de pilotage en rubis synthétique
- Pression différentielle min = 0.3 bar pour l'ouverture et 0 bar pour la fermeture
- Valve uniquement compatible avec huile hydraulique et liquides neutres

LAITON

MONTAGE SUR EMBASE

OUVERTE HORS TENSION

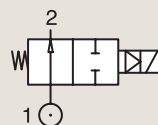

Raccord	Orifice Ø	Facteur d'Écoulement			Pression Différentielle			Temp. Fluide		Joint	Electrovannes PARKER LUCIFER®			Puissance		Groupe Electrique	N° Schéma
					Min bar	Max		Min °C	Max °C		Ref. Valve	Ref. Boîtier	Ref. Bobine	AC W	DC W		
						AC bar	DC bar										
SB	14	-	-	2100	1.5	40	40	-10	50	PUR	322F35	2995	481865	8	9	2.1	7527
	14	46	2.76	-	0.3	40	40	-10	75	NBR	322F72 ₁₂₃	2995	481865	8	9	2.1	3520
	14	46	2.76	-	0.3	40	40	-10	75	NBR	322F72 ₁₂₃	4270	481000	8	8	2.1	3520
	14	45	2.7	-	0.3	40	40	0	100	FKM	322F7206 ₁₂₃₄	2995	481865	8	9	2.1/14.1	3520
	14	45	2.7	-	0.3	40	40	0	120	FKM	322F7206 ₁₂₃₄	4270	481000	8	8	2.1/14.1	3520

Notes:

- Avec vis de réglage du temps de fermeture (4 positions)
- Joint du clapet de pilotage en rubis synthétique
- Pression différentielle min = 0.3 bar pour l'ouverture et 0 bar pour la fermeture
- Valve uniquement compatible avec huile hydraulique et liquides neutres



Dans cette page	Raccord	Orifice (mm)	Kv (l/min)	Pression Diff. Max. (bar)	Temp. Fluide (°C)	Temp. Amb. (°C)
de	14 mm	14	45	13	-10	-10
à	14 mm	14	46	40	140	50



Schéma 3520



Schéma 7527

ELECTROVANNES POUR EAU ET LIQUIDES NEUTRES

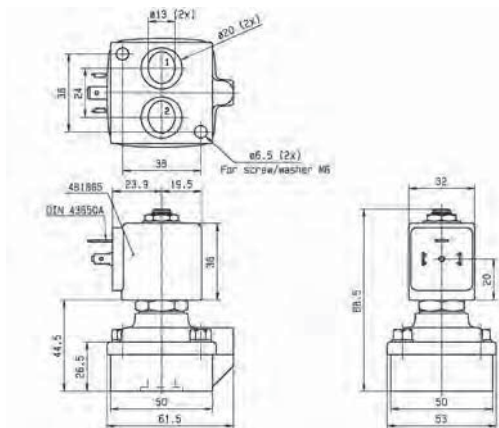

2/2

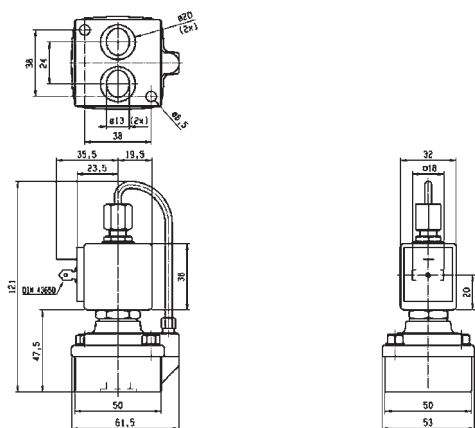
Commande	Corps de Valve	Fonction	Raccord	Orifice (mm)	Facteur d'Écoulement Kv(l/min)	Pression Différentielle (bar)	Temp. Max. Fluide (°C)	Page Valves Parker	Page Valves Parker LUCIFER®
Commande Directe	Laiton/Raccord tuyau	Fermée hors tension	1/8"	1.5 à 3	4.5	20	140	80	84
			1/4"	1.5 à 6	13	20	140	82	84
			3/8"	4 à 6	12	10	120	-	86
		Ouvverte hors tension	1/2"	8.5 à 11	36	4	120	-	86
			1/4"	2.5	3	12	120	-	86
			Commande par impulsion	1/4"	5	11	5	100	-
Servo-commande	Laiton/Montage sur embase	Fermée hors tension	SB	2 à 2.5	3	15	140	90	-
			5 mm	1.5 à 3	4.5	20	120	-	92
Servo-commande	Laiton/Raccord tuyau	Fermée hors tension	1/4"	11 à 12	32	12	120	-	98
			3/8"	11 à 13	50	20	140	94	98
			1/2"	11 à 13	50	20	140	94	100
			3/4"	18 à 20	140	20	140	94	102
			1"	18 à 28	270	20	140	94	104
			1 1/4"	35	420	10	140	96	-
			1 1/2"	40	500	16	140	96	104
			2"	40 à 50	620	16	140	96	104
			Ouvverte hors tension	1/4"	12	32	12	120	-
		3/8"		12 à 13	50	20	140	106	108
		1/2"		12 à 15	60	20	140	106	108
		3/4"		18 à 20	140	20	140	106	108
		1"		18 à 25	180	20	140	106	110
		1 1/4"		35	420	10	140	106	-
		1 1/2"		40	500	12	140	106	110
		2"		50	620	10	140	106	-
		2 1/2"		65	1100	10	90	106	-
		Servo-commande	Laiton/Montage sur embase	Fermée hors tension	3"	75	1334	10	90
14 mm	14				45	40	100	-	110

2/2

ELECTROVANNES POUR EAU ET LIQUIDES NEUTRES COMMANDE DIRECTE



Equipement Commercial



Distribution de Boissons



Systèmes de Chauffage

LAITON RACCORD TUYAU

FERMÉE HORS TENSION

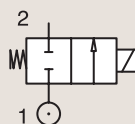

Raccord	Orifice Ø	Facteur d'Écoulement			Pression Différentielle			Temp. Fluide		Joint	Valves Parker			Puissance		Groupe Electrique	N° Schéma	
		Kv l/min	KV m³/h	Qn m³/h	Min bar	Max AC bar	Max DC bar	Min °C	Max °C		N° Commande Valve	Type de Valve	Type de Bobine	AC W	DC W			
BSP	1.5	1.5	0.09	-	0	20	-	-10	140	FKM	363378	PM146BV	ZB09	9	-	20.1/20.2	034	
	1.5	1.5	0.09	-	0	-	18	-10	140	FKM	363378	PM146BV	ZB12	-	12	20.1/20.2	034	
	2.2	2	0.12	-	0	10	-	-10	140	FKM	392349 ₁₂	161.4AV	KT09 115/50	9	-	22.0	043	
	2.2	2	0.12	-	0	10	-	-10	140	FKM	392355 ₁₂	161.4AV	KT09 230/50	9	-	22.0	043	
	2.2	2	0.12	-	0	10	-	-10	140	FKM	392335 ₁₂	161.4AV	KT09 24/50	9	-	22.0	043	
	2.2	2	0.12	-	0	10	-	-10	140	FKM	392366 ₁₂	161.4AV	KT09 240/50	9	-	22.0	043	
	1/8"	2.2	2	0.12	-	0	-	6	-10	140	FKM	392372 ₁₂	161.4AV	KT10 12 DC	-	10	22.0	043
		2.2	2	0.12	-	0	-	6	-10	140	FKM	392370 ₁₂	161.4AV	KT10 24 DC	-	10	22.0	043
		2.5	3.3	0.197	-	0	10	-	-10	140	FKM	363380	PM146FV	ZB09	9	-	20.1/20.2	034
		2.5	3.3	0.197	-	0	-	5	-10	140	FKM	363380	PM146FV	ZB12	-	12	20.1/20.2	034
	2.8	2.9	0.174	-	0	6	-	-10	140	FKM	392389 ₁₂	161.4BV	KT09 115/60	9	-	22.0	043	
	2.8	2.9	0.174	-	0	6	-	-10	140	FKM	392388 ₁₂	161.4BV	KT09 230/50	9	-	22.0	043	
	3	4.5	0.27	-	0	7	-	-10	140	FKM	363390	PM146HV	ZB09	9	-	20.1/20.2	034	
	3	4.5	0.27	-	0	-	2	-10	140	FKM	363390	PM146HV	ZB12	-	12	20.1/20.2	034	

Notes:

1. La référence "N° de Commande" désigne valve + bobine à la tension indiquée dans la colonne type de bobine
2. Pression Max pour la vapeur : 4 Bar (140°C)



Dans cette page	Raccord	Orifice (mm)	Kv (l/min)	Pression Diff. Max. (bar)	Temp. Fluide (°C)	Temp. Amb. (°C)
de	1/8"	1.5	1.5	2	-10	-10
à	1/8"	3	4.5	20	140	50



Schéma 034



Schéma 043

LAITON

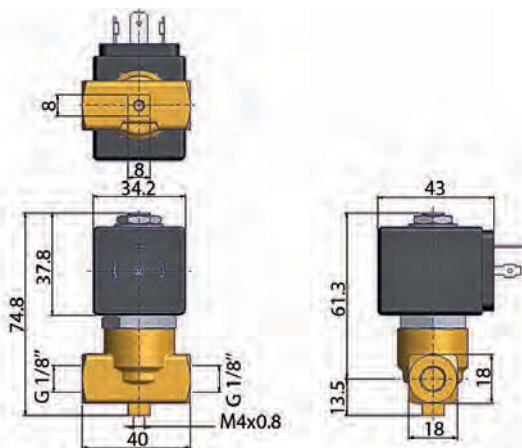
RACCORD TUYAU

FERMÉE HORS TENSION

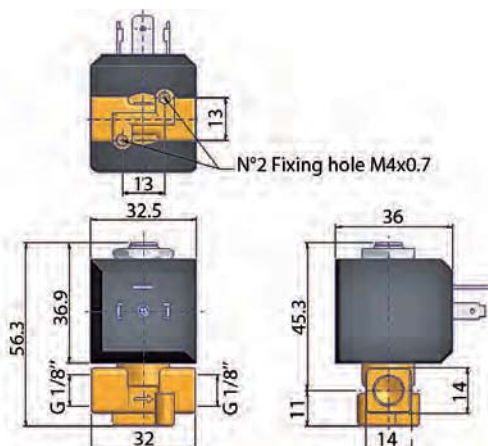
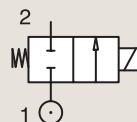

Raccord	Orifice Ø	Facteur d'Écoulement			Pression Différentielle			Temp. Fluide		Joint	Valves Parker			Puissance		Groupe Electrique	N° Schéma
		Kv l/min	KV m³/h	Qn m³/h	Min bar	Max AC bar	Max DC bar	Min °C	Max °C		N° Commande Valve	Type de Valve	Type de Bobine	AC W	DC W		
1/4"	2.2	2	0.12	-	0	10	-	-10	140	FKM	392408 ₁₂	161.4EV	KT09 115/50	9	-	22.0	044
	2.2	2	0.12	-	0	10	-	-10	140	FKM	392408 ₁₂	161.4EV	KT09 115/60	9	-	22.0	044
	2.2	2	0.12	-	0	10	-	-10	140	FKM	392409 ₁₂	161.4EV	KT09 208-230/60	9	-	22.0	044
	2.2	2	0.12	-	0	10	-	-10	140	FKM	392395 ₁₂	161.4EV	KT09 230/50	9	-	22.0	044
	2.2	2	0.12	-	0	10	-	-10	140	FKM	392173 ₁₂	161.4EV	KT09 24/50	9	-	22.0	044
	2.2	2	0.12	-	0	10	-	-10	140	FKM	392396 ₁₂	161.4EV	KT09 240/50	9	-	22.0	044
	2.2	2	0.12	-	0	-	6	-10	140	FKM	392170 ₁₂	161.4EV	KT10 12V DC	-	10	22.0	044
	2.2	2	0.12	-	0	-	6	-10	140	FKM	392169 ₁₂	161.4EV	KT10 24 DC	-	10	22.0	044
	2.5	3.3	0.197	-	0	10	-	-10	140	FKM	363439	PM146WV	ZB09	9	-	20.1/20.2	035
	2.5	3.3	0.197	-	0	-	10	-10	140	FKM	363439	PM146WV	ZB12	-	12	20.1/20.2	035
	3	4.5	0.27	-	0	7	-	-10	140	FKM	363444	PM146YV	ZB09	9	-	20.1/20.2	035
	3	4.5	0.27	-	0	-	4	-10	140	FKM	363444	PM146YV	ZB12	-	12	20.1/20.2	035
	4.5	9	0.527	-	0	6	-	-10	140	FKM	363457	PM146.3KV	ZB14	14	-	20.2	035
	4.5	9	0.527	-	0	-	2.5	-10	140	FKM	363457	PM146.3KV	ZB16	-	16	20.2	035
	6	13	0.75	-	0	6	-	-10	140	FKM	363467	PM146.3ABV	ZB14	14	-	20.2	035
	6	13	0.75	-	0	-	1	-10	140	FKM	363467	PM146.3ABV	ZB16	-	16	20.2	035

Notes:

1. La référence "N° de Commande" désigne valve + bobine à la tension indiquée dans la colonne type de bobine
2. Pression Max pour la vapeur : 4 Bar (140°C)



Dans cette page	Raccord	Orifice (mm)	Kv (l/min)	Pression Diff. Max. (bar)	Temp. Fluide (°C)	Temp. Amb. (°C)
de	1/4"	2.2	2	1	-10	-10
à	1/4"	6	13	10	140	50



Schéma 044



Schéma 035

LAITON

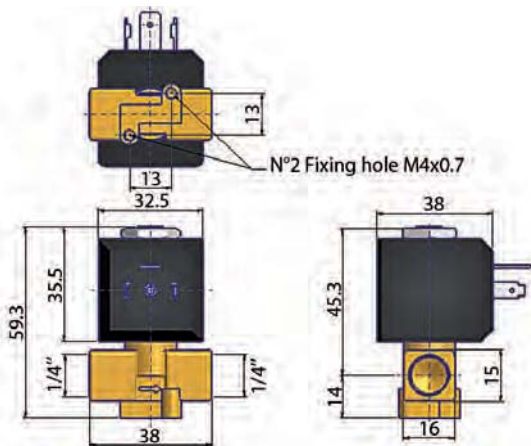
RACCORD TUYAU

FERMÉE HORS TENSION

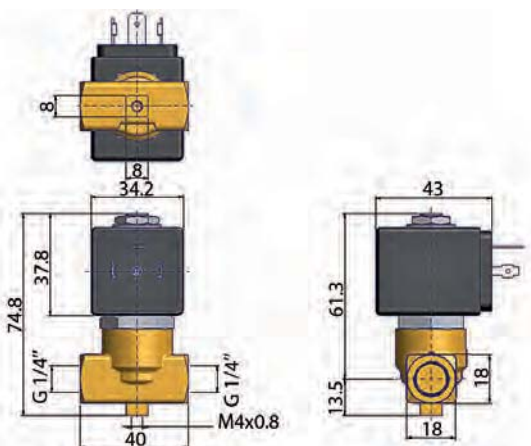
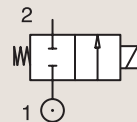

Raccord BSP	Orifice Ø mm	Facteur d'Écoulement			Pression Différentielle			Temp. Fluide		Joint	Electrovannes PARKER LUCIFER®			Puissance		Groupe Électrique	N° Schéma
		Kv l/min	KV m³/h	Qn l/min	Min bar	Max AC bar	Max DC bar	Min °C	Max °C		Ref. Valve	Ref. Boîtier	Ref. Bobine	AC W	DC W		
1/8"	1.5	0.9	0.054	70	0	20	12	-10	75	FKM	121M14	8993	481180	4	5	1.1	3382
	1.5	0.9	0.054	70	0	20	4	-10	75	FKM	121M14	8993	488980	2	2.5	1.1	3382
	2	2	0.12	125	0	10	7	-10	75	FKM	121M13	8993	481180	4	5	1.1	3382
	2	2	0.12	125	0	10	2.5	-10	75	FKM	121M13	8993	488980	2	2.5	1.1	3382
1/4"	1.5	1.5	0.09	80	0	20	20	-10	100	FKM	E121K0402	2995	481865	8	9	2.0/3.0	3510
	1.5	1.5	0.09	80	0	20	20	-10	120	FKM	E121K0402	4270	481000	8	8	2.0/3.0	3510
	2.5	3.5	0.21	220	0	14	7	-10	100	FKM	121K0706	2995	481865	8	9	2.0	3510
	2.5	3.5	0.21	220	0	14	9	-10	120	FKM	121K0706	4270	481000	8	8	2.0	3510
	2.5	3.5	0.21	220	0	14	14	-10	120	FKM	121K0706	4270	486265	14	14	2.0	3510
	3	4.5	0.27	320	0	10	7	-10	100	FKM	E121K0302	2995	481865	8	9	2.0	3510
	3	4.5	0.27	320	0	10	8.5	-10	120	FKM	E121K0302	4270	481000	8	8	2.0	3510
	3	4.5	0.27	320	0	10	7	-10	100	FKM	E121K0302	4270	486265	14	14	2.0	3510
	3	4.5	0.27	320	0	10	7	-10	100	FKM	E121K0352 ₁	2995	481865	8	9	2.0	3510
	3	4.5	0.27	320	0	10	8.5	-10	120	FKM	E121K0352 ₁	4270	481000	8	8	2.0	3510
	3	4.5	0.27	320	0	10	10	-10	120	FKM	E121K0352 ₁	4270	486265	14	14	2.0	3510
	4	7.5	0.45	480	0	10	4	-10	100	FKM	121K02	2995	481865	8	9	2.0	3510
	4	7.5	0.45	480	0	10	5	-10	120	FKM	121K02	4270	481000	8	8	2.0	3510
	4	7.5	0.45	480	0	10	10	-10	120	FKM	121K02	4270	486265	14	14	2.0	3510
	4	7.5	0.45	480	0	10	4	-10	100	FKM	121K0250 ₁	2995	481865	8	9	2.0	3510
	4	7.5	0.45	480	0	10	5	-10	120	FKM	121K0250 ₁	4270	481000	8	8	2.0	3510
	4	7.5	0.45	480	0	10	10	-10	120	FKM	121K0250 ₁	4270	486265	14	14	2.0	3510
	5	11	0.66	750	0	7	2	-10	100	FKM	121K01	2995	481865	8	9	2.0/14.2	3510
	5	11	0.66	750	0	7	2.8	-10	120	FKM	121K01	4270	481000	8	8	2.0/14.2	3510
	5	11	0.66	750	0	7	5	-10	120	FKM	121K01	4270	486265	14	14	2.0/14.2	3510
5	11	0.66	750	0	7	2	-10	100	FKM	121K0106	2995	481865	8	9	2.0	3510	
5	11	0.66	750	0	7	2.8	-10	120	FKM	121K0106	4270	481000	8	8	2.0	3510	
5	11	0.66	750	0	7	5	-10	120	FKM	121K0106	4270	486265	14	14	2.0	3510	
5	11	0.66	750	0	7	2	-10	100	FKM	121K0150 ₁	2995	481865	8	9	2.0	3510	
5	11	0.66	750	0	7	2.8	-10	120	FKM	121K0150 ₁	4270	481000	8	8	2.0	3510	
5	11	0.66	750	0	7	5	-10	120	FKM	121K0150 ₁	4270	486265	14	14	2.0	3510	

Notes:

1. Avec Commande manuelle



Dans cette page	Raccord	Orifice (mm)	Kv (l/min)	Pression Diff. Max. (bar)	Temp. Fluide (°C)	Temp. Amb. (°C)
de	1/8"	1.5	0.9	2	-10	-10
à	1/4"	5	11	20	120	50



Schéma 3382



Schéma 3510

2/2

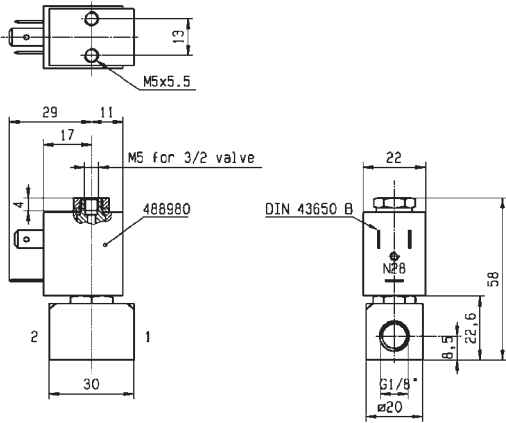
ELECTROVANNES POUR EAU ET LIQUIDES NEUTRES COMMANDE DIRECTE

LAITON

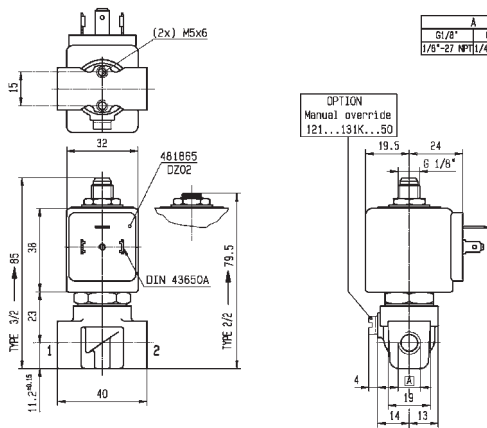
RACCORD TUYAU

FERMÉE HORS TENSION

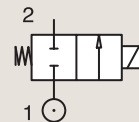

Raccord	Orifice Ø	Facteur d'Écoulement			Pression Différentielle			Temp. Fluide		Joint	Electrovannes PARKER LUCIFER®			Puissance		Groupe Electrique	N° Schéma
					Min	Max		Min	Max		Ref. Valve	Ref. Boîtier	Ref. Bobine	AC W	DC W		
BSP	mm	Kv l/min	KV m³/h	Qn l/min	bar	AC bar	DC bar	°C	°C								
3/8"	4	7.5	0.45	480	0	10	4	-10	100	FKM	121K3206	2995	481865	8	9	2.0	3551
	4	7.5	0.45	480	0	10	5	-10	120	FKM	121K3206	4270	481000	8	8	2.0	3551
	4	7.5	0.45	480	0	10	10	-10	120	FKM	121K3206	4270	486265	14	14	2.0	3551
	5	11	0.66	750	0	7	2	-10	100	FKM	121K3106	2995	481865	8	9	2.0	3551
	5	11	0.66	750	0	7	2.8	-10	120	FKM	121K3106	4270	481000	8	8	2.0	3551
	5	11	0.66	750	0	7	5	-10	120	FKM	121K3106	4270	486265	14	14	2.0	3551
	6	12	0.72	1100	0	5	1.1	-10	100	FKM	121K3306	2995	481865	8	9	2.0/14.2	3551
	6	12	0.72	1100	0	5	1.5	-10	120	FKM	121K3306	4270	481000	8	8	2.0/14.2	3551
1/2"	6	12	0.72	1100	0	5	3	-10	120	FKM	121K3306	4270	486265	14	14	2.0/14.2	3551
	8.5	25	1.5	1600	0	1.1	0.5	-10	100	FKM	E121K46	2995	481865	8	9	2.0	3427
	8.5	25	1.5	1600	0	2.2	0.5	-10	120	FKM	E121K46	4270	481000	8	8	2.0	3427
	8.5	25	1.5	1600	0	4	1.2	-10	120	FKM	E121K46	4270	486265	14	14	2.0	3427
	11	36	2.16	2500	0	0.7	0.3	-10	100	FKM	E121K45	2995	481865	8	9	2.0	3427
	11	36	2.16	2500	0	1.2	0.35	-10	120	FKM	E121K45	4270	481000	8	8	2.0	3427
	11	36	2.16	2500	0	2.5	0.7	-10	120	FKM	E121K45	4270	486265	14	14	2.0	3427

LAITON

RACCORD TUYAU

OUVERTE HORS TENSION

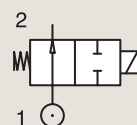

Raccord	Orifice Ø	Facteur d'Écoulement			Pression Différentielle			Temp. Fluide		Joint	Electrovannes PARKER LUCIFER®			Puissance		Groupe Electrique	N° Schéma
					Min	Max		Min	Max		Ref. Valve	Ref. Boîtier	Ref. Bobine	AC W	DC W		
BSP	mm	Kv l/min	KV m³/h	Qn l/min	bar	AC bar	DC bar	°C	°C								
1/4"	2.5	3	0.18	180	0	12	12	-10	100	FKM	122K8306	2995	481865	8	9	2.0	3510
	2.5	3	0.18	180	0	12	12	-10	120	FKM	122K8306	4270	481000	8	8	2.0	3510
	2.5	3	0.18	180	0	12	12	-10	120	FKM	122K8306	4270	486265	14	14	2.0	3510



Dans cette page	Raccord	Orifice (mm)	Kv (l/min)	Pression Diff. Max. (bar)	Temp. Fluide (°C)	Temp. Amb. (°C)
de	1/4"	2,5	3	0,3	-10	-10
à	1/2"	11	36	12	120	50

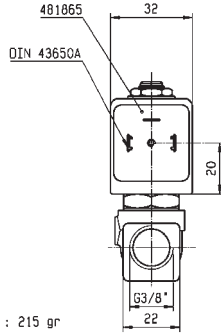
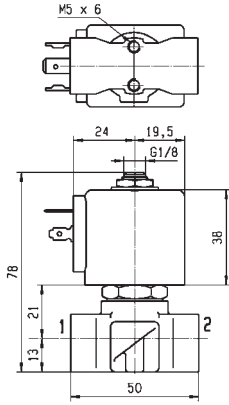

WEIGHT : 215 gr



Schéma 3551



Schéma 3427



Schéma 3510

2/2

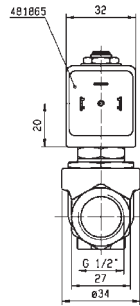
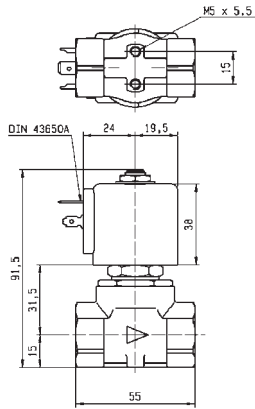
ELECTROVANNES POUR EAU ET LIQUIDES NEUTRES COMMANDE DIRECTE

LAITON

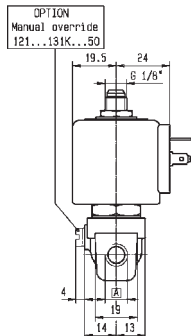
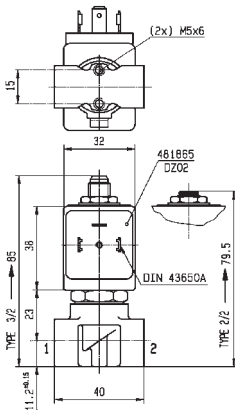
RACCORD TUYAU

COMMANDE PAR IMPULSION

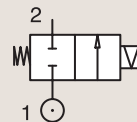

Raccord	Orifice Ø	Facteur d'Écoulement			Pression Différentielle			Temp. Fluide		Joint	Electrovannes PARKER LUCIFER®			Puissance		Groupe Electrique	N° Schéma
		Kv l/min	KV m³/h	Qn l/min	Min bar	Max AC bar	DC bar	Min °C	Max °C		Ref. Valve	Ref. Boîtier	Ref. Bobine	AC W	DC W		
1/4"	5	11	0.66	750	0	5	-	-10	100	FKM	125K01	4269	484990	11	-	4.0	8296
	5	11	0.66	750	0	-	1.5	-10	100	FKM	125K01	4269	485400	-	13	4.0	8296



Dans cette page	Raccord	Orifice (mm)	Kv (l/min)	Pression Diff. Max. (bar)	Temp. Fluide (°C)	Temp. Amb. (°C)
de	1/4"	5	11	1.5	-10	-10
à	1/4"	5	11	5	100	50



Schéma 8296

2/2

ELECTROVANNES POUR EAU ET LIQUIDES NEUTRES COMMANDE DIRECTE

LAITON

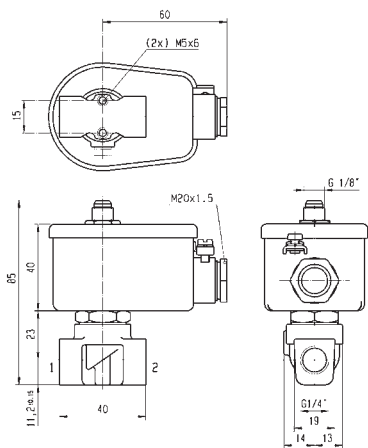
MONTAGE SUR EMBASE

FERMÉE HORS TENSION

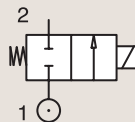

Raccord	Orifice Ø	Facteur d'Écoulement			Pression Différentielle			Temp. Fluide		Joint	Valves Parker			Puissance		Groupe Electrique	N° Schéma
					Min	Max		Min	Max		N° Commande Valve	Type de Valve	Type de Bobine	AC W	DC W		
		bar	AC bar	DC bar	°C	°C											
SB	2	Kv l/min	KV m³/h	Qn m³/h	0	15	-	-10	140	FKM	360469	PM125BV	ZB09	9	-	20.1/20.2	007
	2.5	3	0.18	-	0	10	-	-10	140	FKM	397146J	PM125CV.2	ZB09	9	-	20.1/20.2	007



Dans cette page	Raccord	Orifice (mm)	Kv (l/min)	Pression Diff. Max. (bar)	Temp. Fluide (°C)	Temp. Amb. (°C)
de	SB	2	2	10	-10	-10
à	SB	2.5	3	15	140	50



Schéma 007

2/2

ELECTROVANNES POUR EAU ET LIQUIDES NEUTRES COMMANDE DIRECTE

LAITON

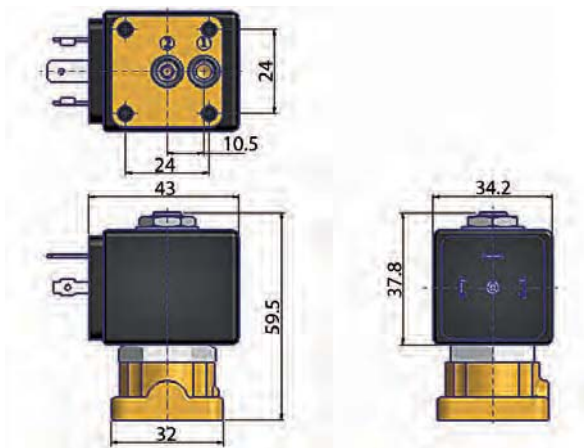
MONTAGE SUR EMBASE

FERMÉE HORS TENSION

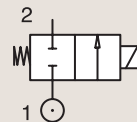

Raccord	Orifice Ø	Facteur d'Écoulement			Pression Différentielle			Temp. Fluide		Joint	Electrovannes PARKER LUCIFER®			Puissance		Groupe Electrique	N° Schéma
											Ref. Valve	Ref. Boîtier	Ref. Bobine	AC W	DC W		
SB	1.5	1.5	0.09	80	0	20	20	-10	100	FKM	E121F4406	2995	481865	8	9	2.0	3509
	1.5	1.5	0.09	80	0	20	20	-10	120	FKM	E121F4406	4270	481000	8	8	2.0	3509
	1.5	1.5	0.09	80	0	20	20	-10	120	FKM	E121F4406	4270	486265	14	14	2.0	3509
	3	4.5	0.27	320	0	10	7	-10	100	FKM	E121F4302	2995	481865	8	9	2.0/3.0	3509
	3	4.5	0.27	320	0	10	8.5	-10	120	FKM	E121F4302	4270	481000	8	8	2.0/3.0	3509
	3	4.5	0.27	320	0	10	10	-10	120	FKM	E121F4302	4270	486265	14	14	2.0/3.0	3509



Dans cette page	Raccord	Orifice (mm)	Kv (l/min)	Pression Diff. Max. (bar)	Temp. Fluide (°C)	Temp. Amb. (°C)
de	5 mm	1.5	1.5	7	-10	-10
à	5 mm	3	4.5	20	120	50

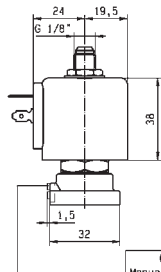
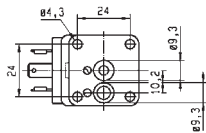

OPTION
Manual override
121...131F...50



Schéma 3509

2/2

ELECTROVANNES POUR EAU ET LIQUIDES NEUTRES SERVO-COMMANDE

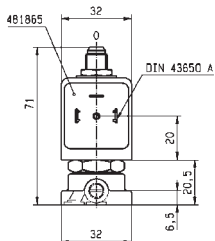

Equipement Commercial



Equipement Industriel



Médical / Instrumentation

LAITON RACCORD TUYAU

FERMÉE HORS TENSION

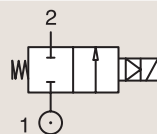

Raccord	Orifice Ø	Facteur d'Écoulement			Pression Différentielle			Temp. Fluide		Joint	Valves Parker			Puissance		Groupe Electrique	N° Schéma
		Kv l/min	KV m³/h	Qn m³/h	Min bar	Max AC bar	Max DC bar	Min °C	Max °C		N° Commande Valve	Type de Valve	Type de Bobine	AC W	DC W		
3/8"	13	50	3	-	0.1	10	10	-10	140	EPDM	443778W ₂	7321BIH00	481865	8	9	2.0	028
						20	20	-10	90	NBR	443776W	7321BIN00	481865	8	9		
						20	20	-10	90	NBR	443777W ₁	7321BIN01	481865	8	9		
						20	20	-10	140	FKM	444492W	7321BIV00	481865	8	9		
1/2"	13	50	3	-	0.1	10	10	-10	140	EPDM	443781W ₂	7321BAH00	481865	8	9	2.0	028
						20	20	-10	90	NBR	443779W	7321BAN00	481865	8	9		
						20	20	-10	90	NBR	443780W ₁	7321BAN01	481865	8	9		
						20	20	-10	140	FKM	444494W	7321BAV00	481865	8	9		
3/4"	20	140	8.4	-	0.1	10	10	-10	140	EPDM	443785W ₂	7321BCH00	481865	8	9	2.0	057
						20	20	-10	90	NBR	443782W	7321BCN00	481865	8	9		
						20	20	-10	90	NBR	443783W ₁	7321BCN01	481865	8	9		
						20	20	-10	140	FKM	444497W	7321BCV00	481865	8	9		
1"	25	160	9.6	-	0.1	10	10	-10	140	EPDM	443789W ₂	7321BDH00	481865	8	9	2.0	057
						20	20	-10	90	NBR	443786W	7321BDN00	481865	8	9		
						20	20	-10	90	NBR	443787W ₁	7321BDN01	481865	8	9		
						20	20	-10	140	FKM	443804W	7321BDV00	481865	8	9		

Notes:

- 1. Avec Commande manuelle
- 2. Pression Max pour la vapeur : 4 Bar (140°C)



Dans cette page	Raccord	Orifice (mm)	Kv (l/min)	Pression Diff. Max. (bar)	Temp. Fluide (°C)	Temp. Amb. (°C)
de	3/8"	13	50	10	-10	-10
à	1"	25	160	20	140	50

G	A		B		C	
NPT	mm	inch	mm	inch	mm	inch
3/8"	69	2.71	99.5	3.91	40	1.57
1/2"	72	2.83	101.5	3.99	40	1.57



Schéma 028

G	A		B		C	
NPT	mm	inch	mm	inch	mm	inch
3/4"	100	3.83	107	4.21	65	2.55
1"	104	4.09	112.5	4.42	65	2.55

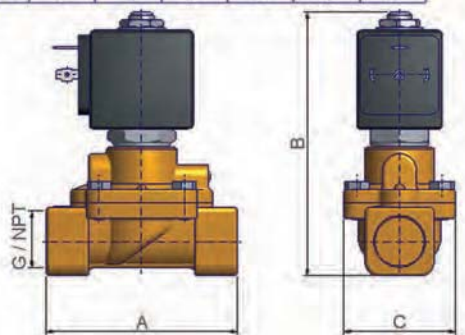

Schéma 057

LAITON

RACCORD TUYAU

FERMÉE HORS TENSION

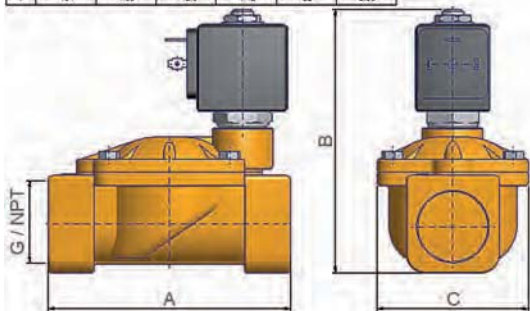
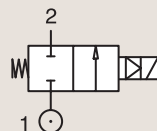

Raccord BSP	Orifice Ø mm	Facteur d'Écoulement			Pression Différentielle			Temp. Fluide		Joint	Valves Parker			Puissance		Groupe Electrique	N° Schéma
		Kv l/min	KV m³/h	Qn m³/h	Min bar	Max AC bar	DC bar	Min °C	Max °C		N° Commande Valve	Type de Valve	Type de Bobine	AC W	DC W		
1 1/4"	35	420	25.2	-	0.1	10	10	-10	140	EPDM	443793W ₂	7321BEH00	481865	8	9	2.0	058
	35	420	25.2	-	0.1	10	10	-10	90	NBR	443790W	7321BEN00	481865	8	9	2.0	058
	35	420	25.2	-	0.1	5	5	-10	90	NBR	443791W ₁	7321BEN01	481865	8	9	2.0	058
1 1/2"	40	500	30	-	0.1	10	10	-10	140	EPDM	443797W ₂	7321BFH00	481865	8	9	2.0	058
	40	500	30	-	0.1	10	10	-10	90	NBR	443794W	7321BFN00	481865	8	9	2.0	058
	40	500	30	-	0.1	5	5	-10	90	NBR	443795W ₁	7321BFN01	481865	8	9	2.0	058
2"	50	620	37.2	-	0.1	10	10	-10	140	EPDM	443801W ₂	7321BGH00	481865	8	9	2.0	058
	50	620	37.2	-	0.1	10	10	-10	90	NBR	443798W	7321BGN00	481865	8	9	2.0	058
	50	620	37.2	-	0.1	5	5	-10	90	NBR	443799W ₁	7321BGN01	481865	8	9	2.0	058

Notes:

1. Avec Commande manuelle
2. Pression Max pour la vapeur : 4 Bar (140°C)



Dans cette page	Raccord	Orifice (mm)	Kv (l/min)	Pression Diff. Max. (bar)	Temp. Fluide (°C)	Temp. Amb. (°C)
de	1 1/4"	35	420	5	-10	-10
à	2"	50	620	10	140	50

G	A		B		C	
NPT	mm	inch	mm	inch	mm	inch
1-1/4"	145	5.70	134	5.27	102	4.01
1-1/2"	145	5.70	134	5.27	102	4.01
2"	173	6.81	148	5.82	118	4.64



Schéma 058

2/2

ELECTROVANNES POUR EAU ET LIQUIDES NEUTRES SERVO-COMMANDE

LAITON

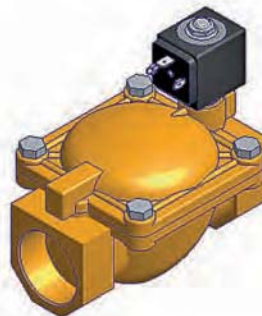
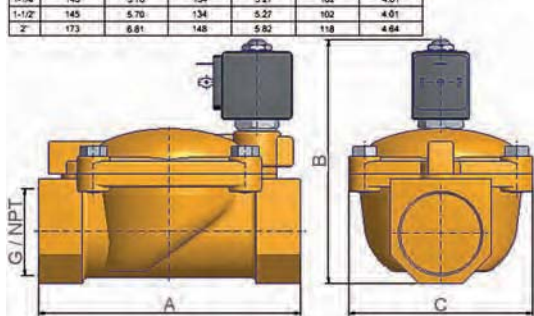
RACCORD TUYAU

FERMÉE HORS TENSION

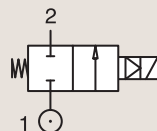

Raccord	Orifice Ø	Facteur d'Écoulement			Pression Différentielle			Temp. Fluide		Joint	Electrovannes PARKER LUCIFER®			Puissance		Groupe Electrique	N° Schéma
											Ref. Valve	Ref. Boîtier	Ref. Bobine	AC W	DC W		
1/4"	11	28	1.68	1800	0.2	10	3	-10	100	FKM	E321K10	2995	481865	8	9	2.0	3429
	11	28	1.68	1800	0.2	10	4	-10	100	FKM	E321K10	4270	481000	8	8	2.0	3429
	12	30	1.8	2150	0.3	10	10	-10	100	FKM	321K31	8993	481180	4	5	1.1	7093
	12	30	1.8	2150	0.3	10	7	-10	75	FKM	321K31	8993	488980	2	2.5	1.1	7093
	12	32	1.92	2150	0.3	12	12	-10	100	NBR	321K4106	2995	481865	8	9	2.1/3.0	7094
	12	32	1.92	2150	0.3	12	12	-10	120	NBR	321K4106	4270	481000	8	8	2.1/3.0	7094
	12	32	1.92	2150	0.3	12	12	-10	120	NBR	321K4106	4270	481000	8	8	2.1/3.0	7094
3/8"	11	36	2.16	2500	0.2	10	4	-10	100	FKM	E321K13	4270	481000	8	8	2.0	3429
	11	36	2.16	2500	0.2	10	10	-10	100	FKM	E321K13	4270	486265	14	14	2.0	3429
	11	36	2.16	2500	0.2	10	-	-10	100	NBR	E321K1314	2995	483466	8 to 11	-	2.0	3429
	11	36	2.16	2500	0.2	10	10	-10	100	NBR	E321K1314	4270	486265	14	14	2.0	3429
	12	45	2.7	3050	0.3	10	10	-10	100	FKM	321K33	8993	481180	4	5	1.1	7093
	12	45	2.7	3050	0.3	10	7	-10	75	FKM	321K33	8993	488980	2	2.5	1.1	7093
	12	45	2.7	3050	0.3	12	12	-10	100	FKM	321K4306	2995	481865	8	9	2.1/3.0	7094
	12	45	2.7	3050	0.3	12	12	-10	120	FKM	321K4306	4270	481000	8	8	2.1/3.0	7094



Dans cette page	Raccord	Orifice (mm)	Kv (l/min)	Pression Diff. Max. (bar)	Temp. Fluide (°C)	Temp. Amb. (°C)
de	1/4"	11	28	3	-10	-10
à	3/8"	12	45	12	120	50



Schéma 3429



Schéma 7093

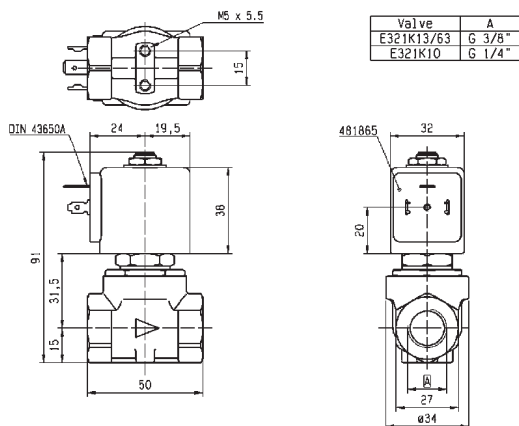

Schéma 7094

2/2

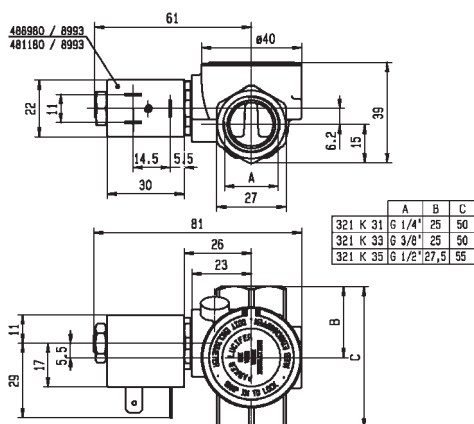
ELECTROVANNES POUR EAU ET LIQUIDES NEUTRES SERVO-COMMANDE

LAITON

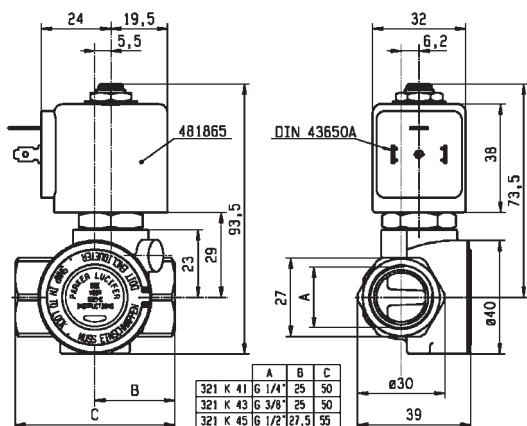
RACCORD TUYAU

FERMÉE HORS TENSION

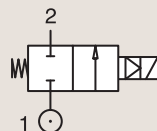

Raccord	Orifice Ø	Facteur d'Ecoulement			Pression Différentielle			Temp. Fluide		Joint	Electrovannes PARKER LUCIFER®			Puissance		Groupe Electrique	N° Schéma
		Kv l/min	KV m³/h	Qn l/min	Min bar	Max AC bar	DC bar	Min °C	Max °C		Ref. Valve	Ref. Boîtier	Ref. Bobine	AC W	DC W		
1/2"	11	36	2.16	2500	0.2	10	3	-10	100	NBR	E321K15	2995	481865	8	9	2.0	3427
	11	36	2.16	2500	0.2	10	10	-10	120	NBR	E321K15	4270	486265	14	14	2.0	3427
	11	36	2.16	2500	0.2	10	3	-10	100	FKM	E321K1514	2995	481865	8	9	2.0	3427
	11	36	2.16	2500	0.2	10	4	-10	120	FKM	E321K1514	-	483371	8	8	2.0	3427
	11	36	2.16	2500	0.2	10	3	-10	100	NBR	E321K25	2995	481865	8	9	2.0	3427
	11	36	2.16	2500	0.2	10	4	-10	120	NBR	E321K25	-	492070	9	8	2.0	3427
	12	50	3	3400	0.3	10	10	-10	100	NBR	321K35	8993	481180	4	5	1.1	7093
	12	50	3	3400	0.3	10	7	-10	75	NBR	321K35	8993	488980	2	2.5	1.1	7093
	12	50	3	3400	0.3	12	12	-10	100	FKM	321K4506	2995	481865	8	9	2.1/3.0	7094
	12	50	3	3400	0.3	12	12	-10	120	FKM	321K4506	4270	481000	8	8	2.1/3.0	7094
	12	50	3	3400	0.3	12	12	-10	100	FKM	321K4556	2995	481865	8	9	2.1/3.0	7094
	12	50	3	3400	0.3	12	12	-10	120	FKM	321K4556	4270	481000	8	8	2.1/3.0	7094

Notes:

1. Avec Commande manuelle



Dans cette page	Raccord	Orifice (mm)	Kv (l/min)	Pression Diff. Max. (bar)	Temp. Fluide (°C)	Temp. Amb. (°C)
de	1/2"	11	36	3	-10	-10
à	1/2"	12	50	12	120	50



Schéma 3427



Schéma 7093

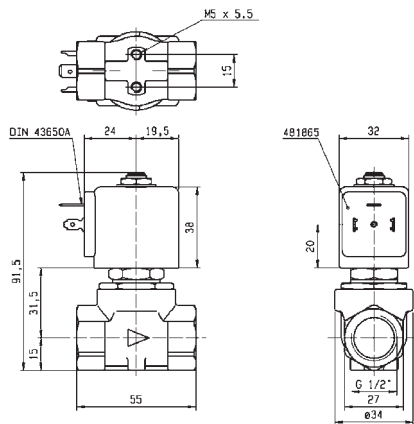

Schéma 7094

2/2

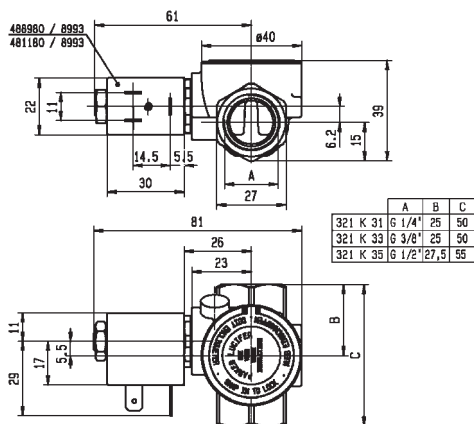
ELECTROVANNES POUR EAU ET LIQUIDES NEUTRES SERVO-COMMANDE

LAITON

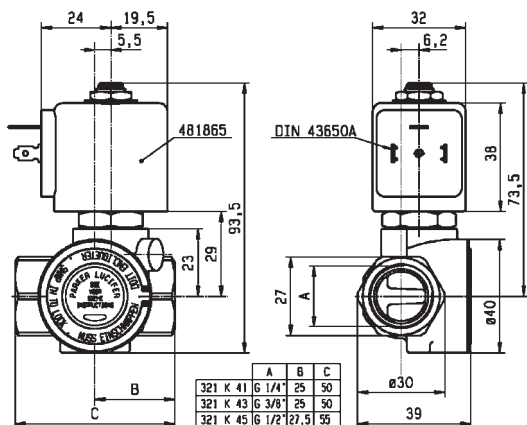
RACCORD TUYAU

FERMÉE HORS TENSION

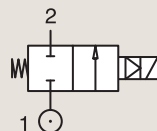

Raccord	Orifice Ø	Facteur d'Écoulement			Pression Différentielle			Temp. Fluide		Joint	Electrovannes PARKER LUCIFER®			Puissance		Groupe Electrique	N° Schéma
		Kv l/min	KV m³/h	Qn l/min	Min bar	Max AC bar DC bar		Min °C	Max °C		Ref. Valve	Ref. Boîtier	Ref. Bobine	AC W	DC W		
3/4"	18	100	6	9400	0.3	10	10	-10	100	NBR	321K36	8993	481180	4	5	1.1	7097
	18	100	6	9400	0.3	10	7	-10	75	NBR	321K36	8993	488980	2	2.5	1.1	7097
	18	100	6	9400	0.3	12	12	-10	100	FKM	321K4606	2995	481865	8	9	2.1/3.0	7099
	18	100	6	9400	0.3	12	12	-10	120	FKM	321K4606	4270	481000	8	8	2.1/3.0	7099
	18	100	6	9400	0.3	12	12	-10	100	FKM	321K4656 ₁	2995	481865	8	9	2.1/3.0	7099
	18	100	6	9400	0.3	12	12	-10	120	FKM	321K4656 ₁	4270	481000	8	8	2.1/3.0	7099
	20	135	8.1	9500	0.3	16	16	-10	100	NBR	E321G36	2995	481865	8	9	2.0	3442
	20	135	8.1	9500	0.3	16	16	-10	100	NBR	E321G36	4270	481000	8	8	2.0	3442

Notes:

1. Avec Commande manuelle



Dans cette page	Raccord	Orifice (mm)	Kv (l/min)	Pression Diff. Max. (bar)	Temp. Fluide (°C)	Temp. Amb. (°C)
de	3/4"	18	100	7	-10	-10
à	3/4"	20	135	16	120	50



Schéma 7097



Schéma 7099

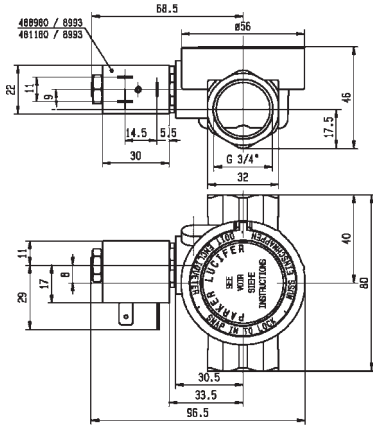

Schéma 3442

	RACCORD	6	C	D	E	F	G	H
321/232/E321G36	BSP 3/4"	121	50	23	54	41	100	70
321/332/E331G37	BSP 1"	121	50	23	54	41	100	70
321/332/E331G38	BSP 1 1/4"	137	55	33	60,5	60	110	70
321/332/E331G39	BSP 1 1/2"	144	75	33	67	60	140	59
321G3966/G3967	DNF 1 7/8"	144	75	33	67	60	140	59
L321A/G32040...	BSP 2"	158,5	80	41,5	73	75	150	99

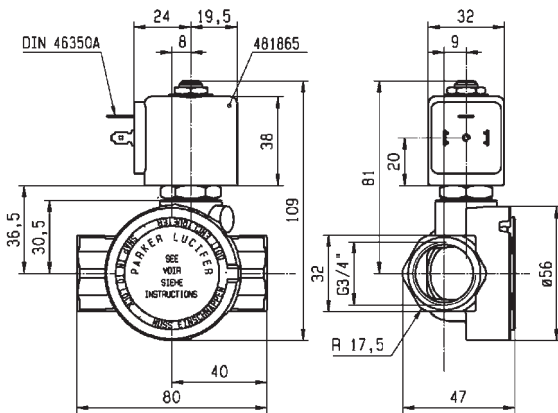
2/2

ELECTROVANNES POUR EAU ET LIQUIDES NEUTRES SERVO-COMMANDE

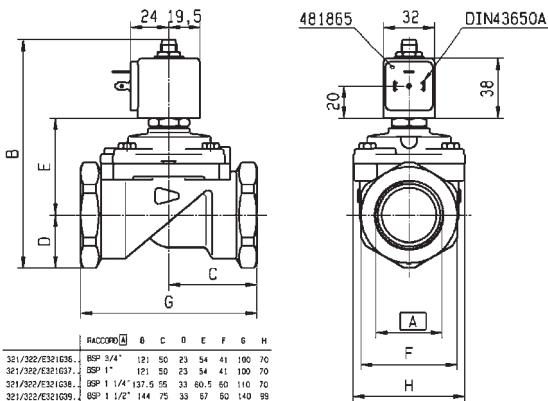
LAITON

RACCORD TUYAU

FERMÉE HORS TENSION

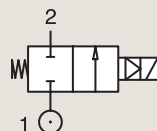

Raccord	Orifice Ø	Facteur d'Écoulement			Pression Différentielle			Temp. Fluide		Joint	Electrovannes PARKER LUCIFER®			Puissance		Groupe Electrique	N° Schéma
					Min	Max		Min	Max		Ref. Valve	Ref. Boîtier	Ref. Bobine	AC W	DC W		
						bar	AC bar										
1"	18	110	6.6	10150	0.3	10	10	-10	100	NBR	321K37	8993	481180	4	5	1.1	7098
	18	110	6.6	10150	0.3	10	7	-10	75	NBR	321K37	8993	488980	2	2.5	1.1	7098
	18	110	6.6	10150	0.3	12	12	-10	100	FKM	321K4706	2995	481865	8	9	2.1/3.0	7100
	18	110	6.6	10150	0.3	12	12	-10	120	FKM	321K4706	4270	481000	8	8	2.1/3.0	7100
	18	110	6.6	10150	0.3	12	12	-10	100	FKM	321K4756 ₁	2995	481865	8	9	2.1/3.0	7100
	18	110	6.6	10150	0.3	12	12	-10	120	FKM	321K4756 ₁	4270	481000	8	8	2.1/3.0	7100
	25	180	10.8	14000	0.3	16	16	-10	100	NBR	E321G37	2995	481865	8	9	2.0	3442
	25	180	10.8	14000	0.3	16	16	-10	100	NBR	E321G37	4270	481000	8	8	2.0	3442
	28	270	16.2	18000	0.3	16	16	-10	100	NBR	E321G38	2995	481865	8	9	2.0	3442
1 1/2"	40	420	25.2	31500	0.3	16	7	-10	100	NBR	E321G39 ₂	2995	481865	8	9	2.0	3442
	40	420	25.2	31500	0.3	16	8.5	-10	100	NBR	E321G39 ₂	4270	481000	8	8	2.0	3442
2"	40	540	32.4	40000	0.3	16	7	-10	100	NBR	E321G40 ₂	2995	481865	8	9	2.0	3442
	40	540	32.4	40000	0.3	16	8.5	-10	100	NBR	E321G40 ₂	4270	481000	8	8	2.0	3442

Notes:

- 1. Avec Commande manuelle
- 2. Joint du clapet de pilotage en rubis synthétique



Dans cette page	Raccord	Orifice (mm)	Kv (l/min)	Pression Diff. Max. (bar)	Temp. Fluide (°C)	Temp. Amb. (°C)
de	1"	18	110	7	-10	-10
à	2"	40	540	16	120	50



Schéma 7098



Schéma 7100

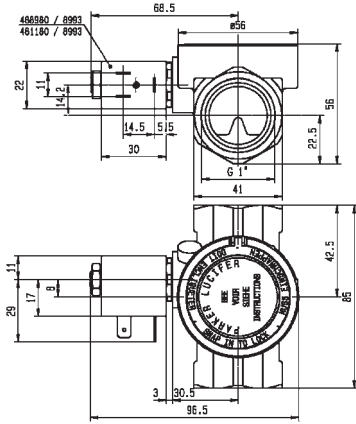

RACCORD	6	C	D	E	F	G	H	
321/322/E321G36	BSP 3/4"	121	50	23	54	41	100	70
321/322/E321G37	BSP 1"	121	50	23	54	41	100	70
321/322/E321G38	BSP 1 1/4"	137	55	33	60,5	60	110	70
321/322/E321G39	BSP 1 1/2"	144	75	33	67	60	140	59
321G2956/G2967	UNF 1 7/8"	144	75	33	67	60	140	59
U321A/G22G40...	BSP 2"	158,5	80	41,5	73	75	150	99

Schéma 3442

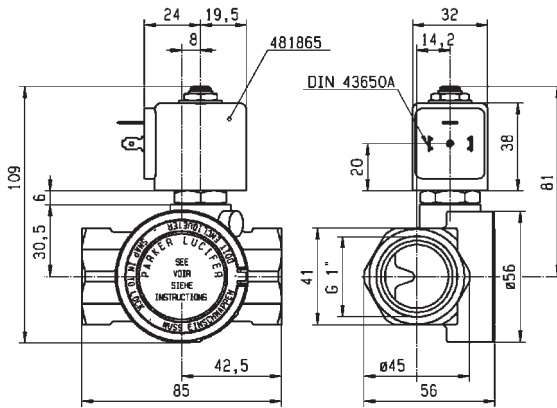
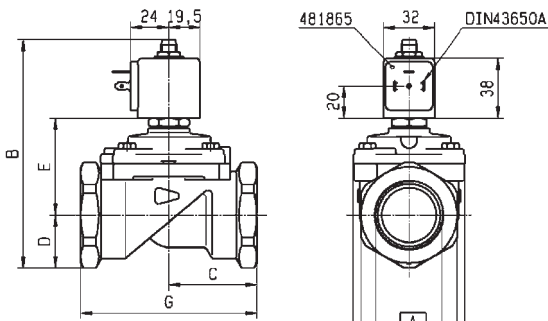
LAITON

RACCORD TUYAU

OUVERTE HORS TENSION

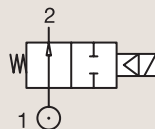

Raccord	Orifice Ø		Facteur d'Écoulement			Pression Différentielle			Temp. Fluide		Joint	Valves Parker			Puissance		Groupe Electrique	N° Schéma
	BSP	mm	Kv l/min	KV m³/h	Qn m³/h	Min bar	Max AC bar	Max DC bar	Min °C	Max °C		N° Commande Valve	Type de Valve	Type de Bobine	AC W	DC W		
3/8"	13	50	3	-	0.1	0.1	10	10	-10	140	EPDM	444600W	7322BIH00	481865	8	9	2.0	060
	13	50	3	-	0.1	20	20	20	-10	90	NBR	443805W	7322BIN00	481865	8	9	2.0	060
	13	50	3	-	0.1	20	20	20	-10	140	FKM	444499W	7322BIV00	481865	8	9	2.0	060
1/2"	13	50	3	-	0.1	10	10	10	-10	140	EPDM	444601W	7322BAH00	481865	8	9	2.0	060
	13	50	3	-	0.1	20	20	20	-10	90	NBR	443806W	7322BAN00	481865	8	9	2.0	060
	13	50	3	-	0.1	20	20	20	-10	140	FKM	444500W	7322BAV00	481865	8	9	2.0	060
3/4"	20	140	8.4	-	0.1	10	10	10	-10	140	EPDM	444602W	7322BCH00	481865	8	9	2.0	061
	20	140	8.4	-	0.1	20	20	20	-10	90	NBR	443807W	7322BCN00	481865	8	9	2.0	061
	20	140	8.4	-	0.1	20	20	20	-10	140	FKM	444501W	7322BCV00	481865	8	9	2.0	061
1"	25	160	9.6	-	0.1	10	10	10	-10	140	EPDM	444603W	7322BDH00	481865	8	9	2.0	061
	25	160	9.6	-	0.1	20	20	20	-10	90	NBR	443808W	7322BDN00	481865	8	9	2.0	061
	25	160	9.6	-	0.1	20	20	20	-10	140	FKM	444502W	7322BDV00	481865	8	9	2.0	061
1 1/4"	35	420	25.2	-	0.1	10	10	10	-10	140	EPDM	444576W	7322BEH00	481865	8	9	2.0	062
	35	420	25.2	-	0.1	10	10	10	-10	90	NBR	443809W	7322BEN00	481865	8	9	2.0	062
1 1/2"	40	500	30	-	0.1	10	10	10	-10	140	EPDM	444604W	7322BFH00	481865	8	9	2.0	062
	40	500	30	-	0.1	10	10	10	-10	90	NBR	443810W	7322BFN00	481865	8	9	2.0	062
2"	50	620	37.2	-	0.1	10	10	10	-10	140	EPDM	444605W	7322BGH00	481865	8	9	2.0	062
	50	620	37.2	-	0.1	10	10	10	-10	90	NBR	443811W	7322BGN00	481865	8	9	2.0	062
2 1/2"	65	1100	66	-	0.2	10	10	10	-10	90	NBR	444513W	7322BLN06	481865	8	9	2.0	063
3"	75	1334	80	-	0.2	10	10	10	-10	90	NBR	444503W	7322BMN06	481865	8	9	2.0	063

G	A		B		C	
NPT	mm	inch	mm	inch	mm	inch
1-1/4"	145	5.70	144.5	5.68	102	4.01
1-1/2"	145	—	134	—	102	—
2"	173	—	148	—	118	—



Schéma 062



Dans cette page	Raccord	Orifice (mm)	Kv (l/min)	Pression Diff. Max. (bar)	Temp. Fluide (°C)	Temp. Amb. (°C)
de	3/8"	13	50	10	-10	-10
à	3"	75	1334	20	140	50

G	A		B		C	
	mm	inch	mm	inch	mm	inch
3/8"	89	2.71	110	4.33	40	1.57
1/2"	72	2.83	112	4.41	40	1.57

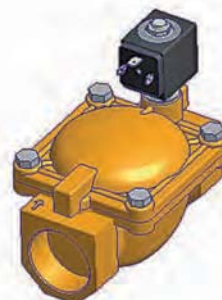
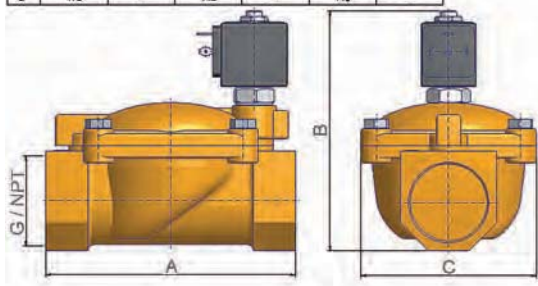

Schéma 060

G	A		B		C	
	mm	inch	mm	inch	mm	inch
3/4"	100	3.83	117.5	4.62	65	2.55
1"	104	4.09	123	4.84	65	2.55



Schéma 061

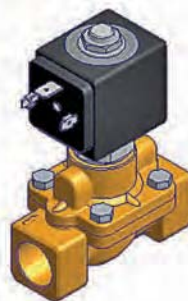
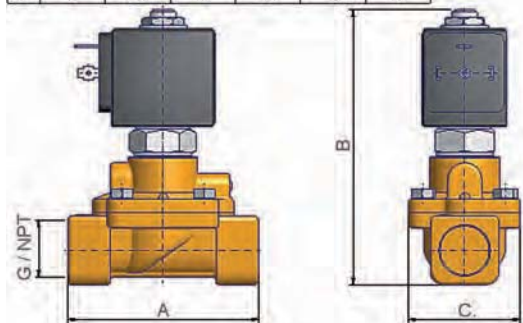

Schéma 063

LAITON

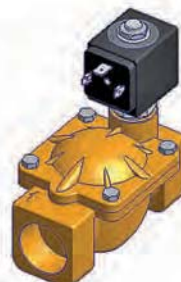
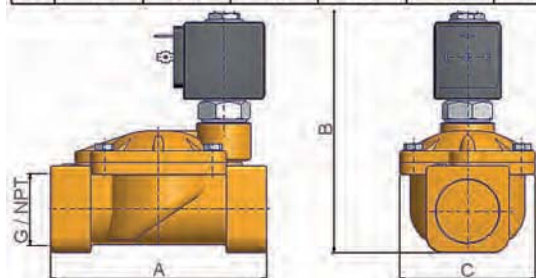
RACCORD TUYAU

OUVERTE HORS TENSION

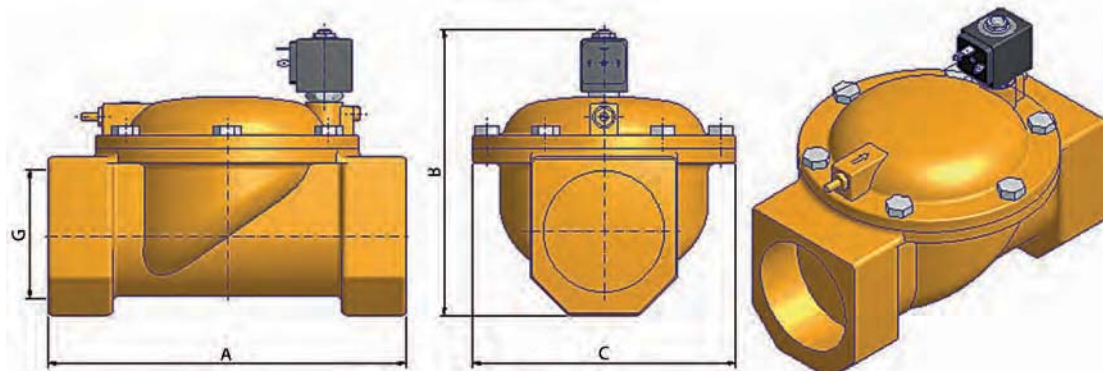
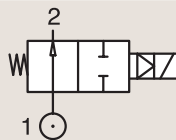

Raccord	Orifice Ø	Facteur d'Écoulement			Pression Différentielle			Temp. Fluide		Joint	Electrovannes PARKER LUCIFER®			Puissance		Groupe Electrique	N° Schéma
					Min	Max		Min	Max		Ref. Valve	Ref. Boîtier	Ref. Bobine	AC W	DC W		
BSP	mm	Kv l/min	KV m³/h	Qn l/min	bar	AC bar	DC bar	°C	°C								
1/4"	12	32	1.92	2150	0.3	12	12	-10	100	FKM	322K4106	2995	481865	8	9	2.1	7094
	12	32	1.92	2150	0.3	12	12	-10	120	FKM	322K4106	4270	481000	8	8	2.1	7094
3/8"	12	45	2.7	3050	0.3	12	12	-10	100	FKM	322K4306	2995	481865	8	9	2.1	7094
	12	45	2.7	3050	0.3	12	12	-10	120	FKM	322K4306	4270	481000	8	8	2.1	7094
1/2"	12	50	3	3400	0.3	12	12	-10	100	FKM	322K4506	2995	481865	8	9	2.1	7094
	12	50	3	3400	0.3	12	12	-10	120	FKM	322K4506	4270	481000	8	8	2.1	7094
	15	60	3.6	3890	0.3	15	15	-10	100	NBR	322G75	2995	481865	8	9	2.1	3522
	15	60	3.6	3890	0.3	15	15	-10	100	NBR	322G75	4270	481000	8	8	2.1	3522
3/4"	18	100	6	9400	0.3	12	12	-10	100	FKM	322K4606	2995	481865	8	9	2.1	7099
	18	100	6	9400	0.3	12	12	-10	120	FKM	322K4606	4270	481000	8	8	2.1	7099
	20	135	8.1	9500	0.3	16	16	-10	100	NBR	322G36	2995	481865	8	9	2.1	3442
	20	135	8.1	9500	0.3	16	16	-10	100	NBR	322G36	4270	481000	8	8	2.1	3442

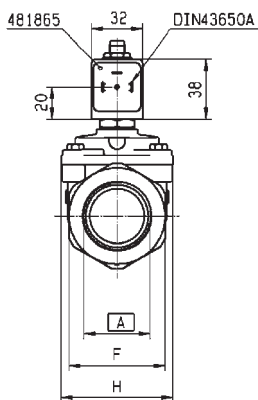
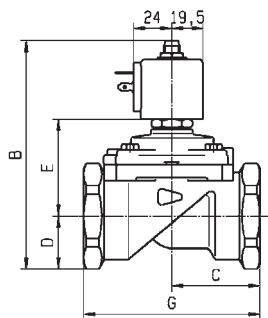

RACCORDE	B	C	D	E	F	G	H
321/322/E321G38..	BSP 3/4"	121	50	23	54	41	100 70
321/322/E321G37..	OSP 1"	151	50	23	54	41	100 70
321/322/E321G38..	OSP 1 1/4"	137.5	55	33	60.5	60	110 70
321/322/E321G29..	BSP 1 1/2"	144	75	33	87	80	140 99
321G2966/G2967	ENF 1 7/8"	144	75	33	87	60	140 99
L321A/G22G40..	BSP 2"	158.5	80	41.5	73	75	150 99

Schéma 3442



Dans cette page	Raccord	Orifice (mm)	Kv (l/min)	Pression Diff. Max. (bar)	Temp. Fluide (°C)	Temp. Amb. (°C)
de	1/4"	12	32	12	-10	-10
à	3/4"	20	135	16	120	50



Schéma 7094



Schéma 3522

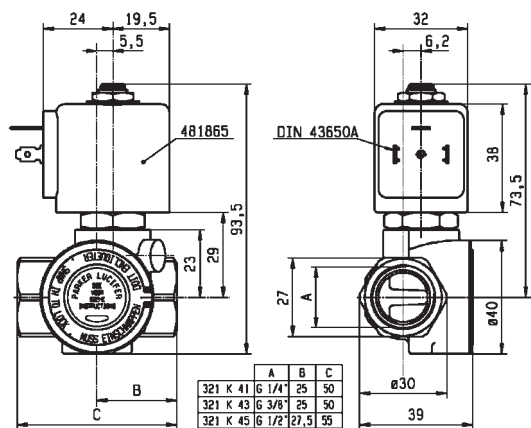

Schéma 7099

2/2

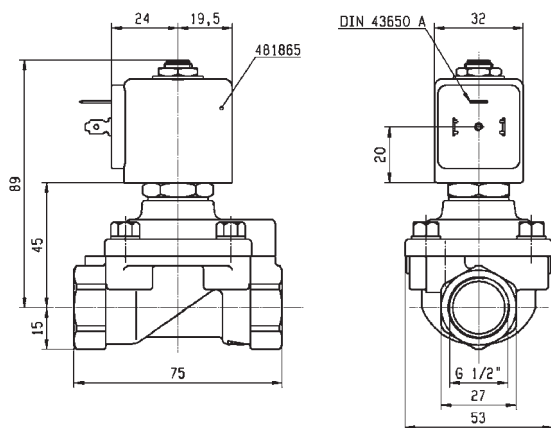
ELECTROVANNES POUR EAU ET LIQUIDES NEUTRES SERVO-COMMANDE

LAITON

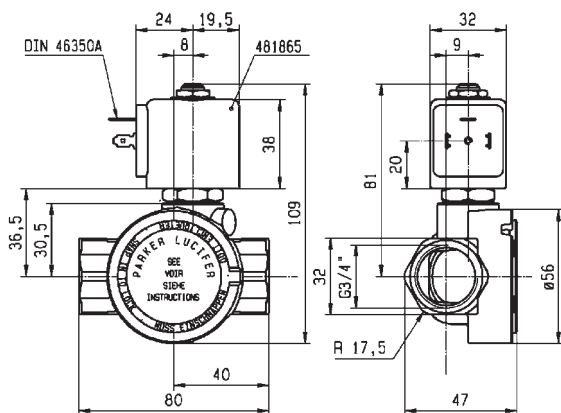
RACCORD TUYAU

OUVERTE HORS TENSION

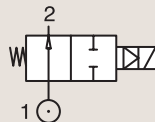

Raccord	Orifice Ø	Facteur d'Écoulement			Pression Différentielle			Temp. Fluide		Joint	Electrovannes PARKER LUCIFER®			Puissance		Groupe Electrique	N° Schéma
					Min bar	Max		Min °C	Max °C		Ref. Valve	Ref. Boîtier	Ref. Bobine	AC W	DC W		
						AC bar	DC bar										
BSP	mm	Kv l/min	KV m³/h	Qn l/min													
1"	18	110	6.6	10150	0.3	12	12	-10	100	FKM	322K4706	2995	481865	8	9	2.0	7100
	18	110	6.6	10150	0.3	12	12	-10	120	FKM	322K4706	4270	481000	8	8	2.0	7100
	25	180	10.8	14000	0.3	16	16	-10	100	NBR	322G37	2995	481865	8	9	2.1	3442
	25	180	10.8	14000	0.3	16	16	-10	100	NBR	322G37	4270	481000	8	8	2.1	3442
1 1/2"	40	420	25.2	31500	0.3	12	12	-10	100	NBR	322G39	2995	481865	8	9	2.1	3442
	40	420	25.2	31500	0.3	12	12	-10	100	NBR	322G39	4270	481000	8	8	2.1	3442

LAITON

MONTAGE SUR EMBASE

FERMÉE HORS TENSION

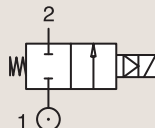

Raccord	Orifice Ø	Facteur d'Écoulement			Pression Différentielle			Temp. Fluide		Joint	Electrovannes PARKER LUCIFER®			Puissance		Groupe Electrique	N° Schéma
					Min bar	Max		Min °C	Max °C		Ref. Valve	Ref. Boîtier	Ref. Bobine	AC W	DC W		
						AC bar	DC bar										
SB	mm	Kv l/min	KV m³/h	Qn l/min													
SB	14	45	2.7	2100	0.3	40	25	-10	100	NBR	E321F32 ₁	2995	481865	8	9	2.0	3520
	14	45	2.7	2100	0.3	40	30	-10	100	NBR	E321F32 ₁	4270	481000	8	8	2.0	3520
	14	45	2.7	2100	0.3	40	40	-10	100	NBR	E321F32 ₁	4270	486265	14	14	2.0	3520

Notes:

1. Joint du clapet de pilotage en rubis synthétique



Dans cette page	Raccord	Orifice (mm)	Kv (l/min)	Pression Diff. Max. (bar)	Temp. Fluide (°C)	Temp. Amb. (°C)
de	14 mm	14	45	12	-10	-10
à	1 1/2"	40	420	40	120	50



Schéma 7100



Schéma 3442

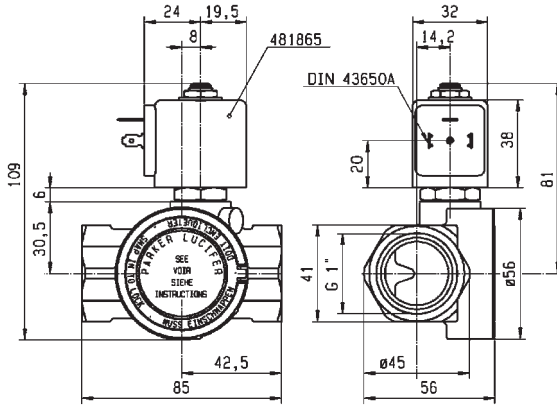

Schéma 3520

ELECTROVANNES ANTI-COUP DE BÉLIER

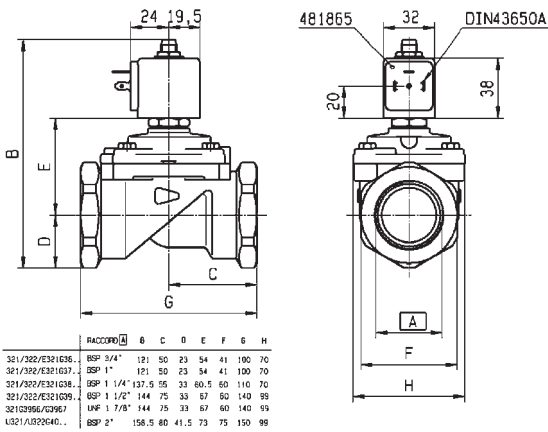

Eau

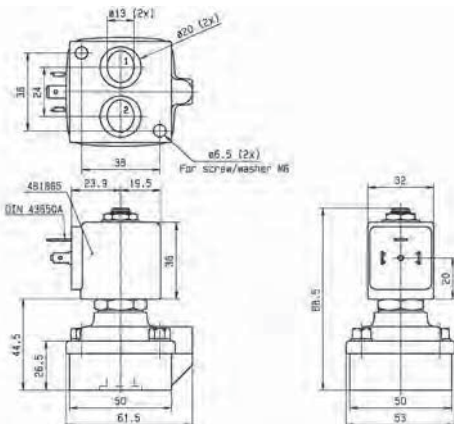
2/2

Commande	Corps de Valve	Fonction	Raccord	Orifice (mm)	Facteur d'Écoulement Kv(l/min)	Pression Différentielle (bar)	Temp. Max. Fluide (°C)	Page Valves Parker	Page Valves Parker LUCIFER®
Attraction forcée	Laiton/Raccord tuyau	Fermée hors tension	1"	15 à 25	170	10	140	-	114
			1/4"	12	32	12	120	-	118
Servo-commande	Laiton/Raccord tuyau	Fermée hors tension	3/8"	12	45	12	120	-	118
			1/2"	12	50	12	120	-	118
			3/4"	18 à 20	135	16	120	-	118
			1"	18 à 25	180	16	120	116	120
			1 1/4"	25 à 28	280	16	100	116	120
			1 1/2"	35 à 40	500	16	100	116	120
			2"	40 à 50	620	16	100	116	120
			2 1/2"	65	1100	10	90	116	-
			3"	75	1334	10	90	116	-
			Ouverte hors tension	3/4"	20	135	16	100	-
		1"		25	180	16	100	-	122
		1 1/4"		28	270	16	100	-	122
1 1/2"	40	425		12	100	-	122		
			2"	40	540	12	100	-	122

2/2

ELECTROVANNES ANTI-COUP DE BÉLIER ATTRACTION FORCÉE



Équipement Commercial

LAITON
RACCORD TUYAU

FERMÉE HORS TENSION

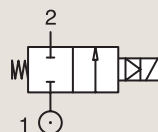

Raccord	Orifice Ø	Facteur d'Écoulement			Pression Différentielle			Temp. Fluide		Joint	Electrovannes PARKER LUCIFER®			Puissance		Groupe Électrique	N° Schéma
		Kv l/min	KV m³/h	Qn l/min	Min bar	Max AC bar DC bar		Min °C	Max °C		Ref. Valve	Ref. Boîtier	Ref. Bobine	AC W	DC W		
1"	15	80	4.8	6000	0	-	10	-10	100	FKM	221G1731 ¹²	2995	481865	-	9	2.1	3445
	15	80	4.8	6000	0	10	10	-10	120	FKM	221G1731 ¹²	-	492070	9	8	2.1	3445
	15	80	4.8	6000	0	10	10	-10	120	FKM	221G1731 ¹²	-	492190	11	9	2.1	3445
	25	160	9.6	-	0	10	-	0	100	EPDM	221G2103	2995	481865	8	-	2.0	3448
	25	160	9.6	-	0	10	-	0	120	EPDM	221G2103	4270	481000	8	-	2.0	3448
	25	160	9.6	-	0	10	10	0	120	EPDM	221G2103	4270	486265	14	14	2.0	3448
	25	160	9.6	-	0	4	4	0	140	EPDM	221G2103	2995	492425	14	14	2.0	3448
	25	170	10.2	14000	0	-	10	-10	100	FKM	221G2131 ¹²	2995	481865	-	9	2.1	3448
	25	170	10.2	14000	0	10	10	-25	40	FKM	221G2131 ¹²	-	492070	9	8	2.1	3448
	25	170	10.2	14000	0	10	10	-25	40	FKM	221G2131 ¹²	-	492190	11	9	2.1	3448

Notes:

1. Avec vis de réglage du temps de fermeture (4 positions)
2. Tension continue uniquement (ou bobine avec pont redresseur)



Dans cette page	Raccord	Orifice (mm)	Kv (l/min)	Pression Diff. Max. (bar)	Temp. Fluide (°C)	Temp. Amb. (°C)
de	1"	15	80	4	-25	-10
à	1"	25	170	10	140	50



Schéma 3445



Schéma 3448

2/2

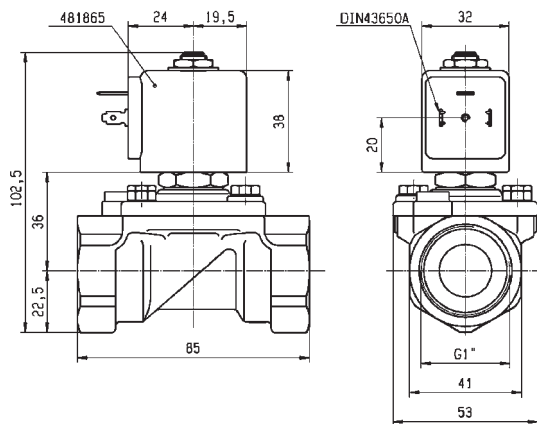
ELECTROVANNES ANTI-COUP DE BÉLIER SERVO-COMMANDE

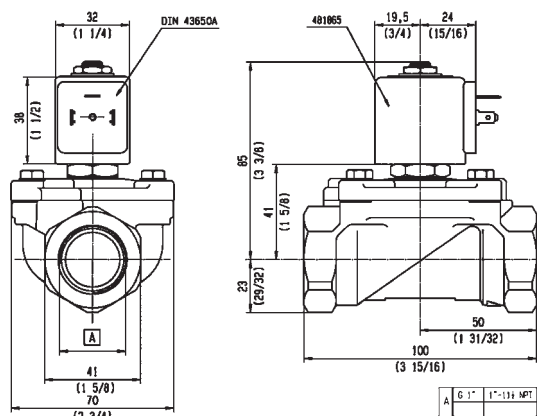

Équipement Commercial



Équipement Industriel



Médical / Instrumentation

LAITON RACCORD TUYAU

FERMÉE HORS TENSION

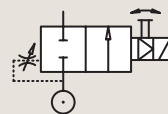

Raccord	Orifice Ø	Facteur d'Écoulement			Pression Différentielle			Temp. Fluide		Joint	Valves Parker			Puissance		Groupe Electrique	N° Schéma
		Kv l/min	KV m³/h	Qn m³/h	Min bar	Max AC bar	DC bar	Min °C	Max °C		N° Commande Valve	Type de Valve	Type de Bobine	AC W	DC W		
1"	20	140	8.4	-	0.1	10	10	-10	90	NBR	443784W ₁	7321BCN02	481865	8	9	2.0	057
1 1/4"	25	160	9.6	-	0.1	10	10	-10	90	NBR	443788W ₁	7321BDN02	481865	8	9	2.0	057
1 1/2"	35	420	25.2	-	0.1	5	5	-10	90	NBR	443792W ₁	7321BEN02	481865	8	9	2.0	058
	40	500	30	-	0.1	5	5	-10	90	NBR	443796W ₁	7321BFN02	481865	8	9	2.0	058
2"	50	620	37.2	-	0.1	5	5	-10	90	NBR	443800W ₁	7321BGN02	481865	8	9	2.0	058
2 1/2"	65	1100	66	-	0.2	10	10	-10	90	NBR	443802W ₁	7321BLN02	481865	8	9	2.0	059
3"	75	1334	80	-	0.2	10	10	-10	90	NBR	443803W ₁	7321BMN02	481865	8	9	2.0	059

Notes:

1. Avec Commande manuelle



Dans cette page	Raccord	Orifice (mm)	Kv (l/min)	Pression Diff. Max. (bar)	Temp. Fluide (°C)	Temp. Amb. (°C)
de	1"	20	140	5	-10	-10
à	3"	75	1334	10	90	50

G	A		B		C	
NPT	mm	inch	mm	inch	mm	inch
3/4"	100	3.83	107	4.21	65	2.55
1"	104	4.09	112.5	4.42	65	2.55



Schéma 057

G	A		B		C	
NPT	mm	inch	mm	inch	mm	inch
1-1/4"	145	5.70	134	5.27	102	4.01
1-1/2"	145	5.70	134	5.27	102	4.01
2"	173	6.81	148	5.82	118	4.64

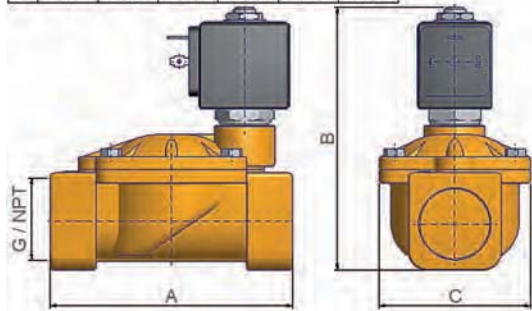

Schéma 058

G	A		B		C	
	mm	inch	mm	inch	mm	inch
2-1/2"	245	---	195	---	184	---
3"	250	---	195	---	184	---

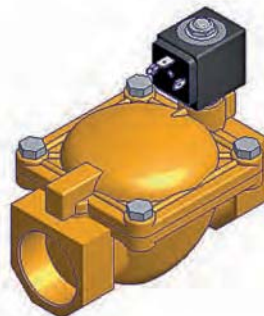
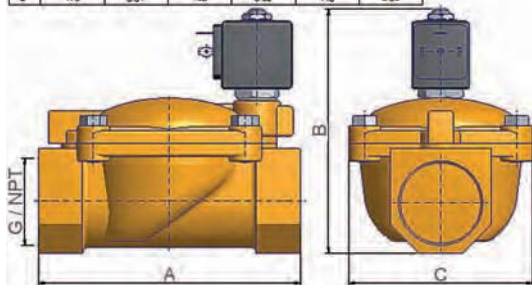

Schéma 059

2/2

ELECTROVANNES ANTI-COUP DE BÉLIER SERVO-COMMANDE

LAITON

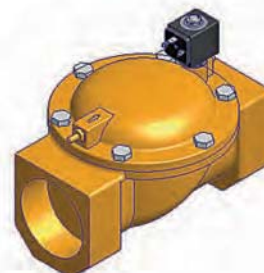
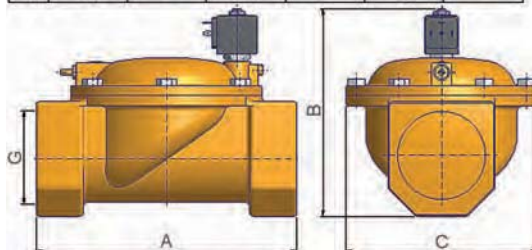
RACCORD TUYAU

FERMÉE HORS TENSION

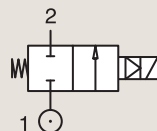

Raccord	Orifice Ø	Facteur d'Écoulement			Pression Différentielle			Temp. Fluide		Joint	Electrovannes PARKER LUCIFER®			Puissance		Groupe Electrique	N° Schéma
					Min	Max		Min	Max		Ref. Valve	Ref. Boîtier	Ref. Bobine	AC W	DC W		
BSP	mm	Kv l/min	KV m³/h	Qn l/min	bar	AC bar	DC bar	°C	°C								
1/4"	12	32	1.92	2150	0.3	12	12	-10	100	NBR	321K4106	2995	481865	8	9	2.1/3.0	7094
	12	32	1.92	2150	0.3	12	12	-10	120	NBR	321K4106	4270	481000	8	8	2.1/3.0	7094
3/8"	12	45	2.7	3050	0.3	12	12	-10	100	FKM	321K4306	2995	481865	8	9	2.1/3.0	7094
	12	45	2.7	3050	0.3	12	12	-10	120	FKM	321K4306	4270	481000	8	8	2.1/3.0	7094
1/2"	12	50	3	3400	0.3	12	12	-10	100	FKM	321K4506	2995	481865	8	9	2.1/3.0	7094
	12	50	3	3400	0.3	12	12	-10	120	FKM	321K4506	4270	481000	8	8	2.1/3.0	7094
	12	50	3	3400	0.3	12	12	-10	100	FKM	321K4556 ₁	2995	481865	8	9	2.1/3.0	7094
	12	50	3	3400	0.3	12	12	-10	120	FKM	321K4556 ₁	4270	481000	8	8	2.1/3.0	7094
3/4"	18	100	6	9400	0.3	12	12	-10	100	FKM	321K4606	2995	481865	8	9	2.1/3.0	7099
	18	100	6	9400	0.3	12	12	-10	120	FKM	321K4606	4270	481000	8	8	2.1/3.0	7099
	18	100	6	9400	0.3	12	12	-10	100	FKM	321K4656 ₁	2995	481865	8	9	2.1/3.0	7099
	18	100	6	9400	0.3	12	12	-10	120	FKM	321K4656 ₁	4270	481000	8	8	2.1/3.0	7099
	20	135	8.1	9500	0	16	16	-10	100	NBR	E321G3610 ₂	2995	481865	8	9	2.0	3442
	20	135	8.1	9500	0	16	16	-10	100	NBR	E321G3610 ₂	4270	481000	8	8	2.0	3442

Notes:

1. Avec Commande manuelle

2. Avec commande manuelle et vis de réglage du temps de fermeture à 4 positions- Sans cette option: même référence en otant le suffixe '10', ex. E321G36

2/2

ELECTROVANNES ANTI-COUP DE BÉLIER SERVO-COMMANDE

LAITON

RACCORD TUYAU

FERMÉE HORS TENSION

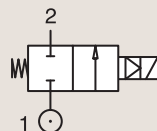

Raccord	Orifice Ø	Facteur d'Écoulement			Pression Différentielle			Temp. Fluide		Joint	Electrovannes PARKER LUCIFER®			Puissance		Groupe Electrique	N° Schéma
		Kv l/min	KV m³/h	Qn l/min	Min bar	Max AC bar	Max DC bar	Min °C	Max °C		Ref. Valve	Ref. Boîtier	Ref. Bobine	AC W	DC W		
1"	18	110	6.6	10150	0.3	12	12	-10	100	FKM	321K4706	2995	481865	8	9	2.1/3.0	7100
	18	110	6.6	10150	0.3	12	12	-10	120	FKM	321K4706	4270	481000	8	8	2.1/3.0	7100
	18	110	6.6	10150	0.3	12	12	-10	100	FKM	321K4756 ₁	2995	481865	8	9	2.1/3.0	7100
	18	110	6.6	10150	0.3	12	12	-10	120	FKM	321K4756 ₁	4270	481000	8	8	2.1/3.0	7100
	25	180	10.8	14000	0.3	16	16	-10	100	NBR	E321G3710 ₂	2995	481865	8	9	2.0	3442
	25	180	10.8	14000	0.3	16	16	-10	100	NBR	E321G3710 ₂	4270	481000	8	8	2.0	3442
1 1/4"	28	280	16.8	18000	0.3	16	16	-10	100	NBR	E321G3810 ₂	2995	481865	8	9	2.0	3442
	28	280	16.8	18000	0.3	16	16	-10	100	NBR	E321G3810 ₂	4270	481000	8	8	2.0	3442
1 1/2"	40	420	25.2	31500	0.3	16	7	-10	100	FKM	E321G3910 ₂	2995	481865	8	9	2.0	3442
	40	420	25.2	31500	0.3	16	8.5	-10	100	FKM	E321G3910 ₂	4270	481000	8	8	2.0	3442
2"	40	540	32.4	40000	0.3	16	7	-10	100	FKM	E321G4010 ₂	2995	481865	8	9	2.0	3442
	40	540	32.4	40000	0.3	16	8.5	-10	100	FKM	E321G4010 ₂	4270	481000	8	8	2.0	3442

Notes:

1. Avec Commande manuelle

2. Avec commande manuelle et vis de réglage du temps de fermeture à 4 positions- Sans cette option: même référence en otant le suffixe '10', ex. E321G36



Dans cette page	Raccord	Orifice (mm)	Kv (l/min)	Pression Diff. Max. (bar)	Temp. Fluide (°C)	Temp. Amb. (°C)
de	1"	18	110	7	-10	-10
à	2"	40	540	16	120	50



Schéma 7100



Schéma 3442

2/2

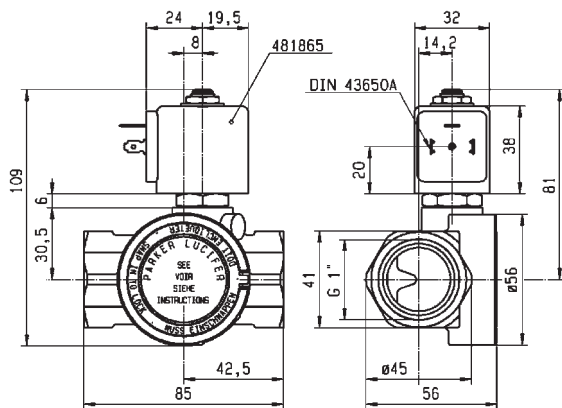
ELECTROVANNES ANTI-COUP DE BÉLIER SERVO-COMMANDE

LAITON

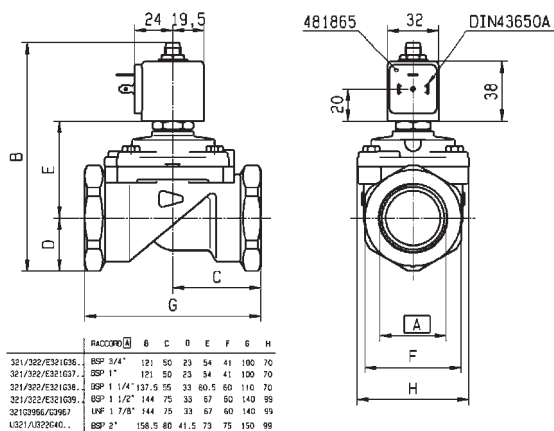
RACCORD TUYAU

OUVERTE HORS TENSION

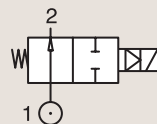

Raccord	Orifice Ø	Facteur d'Écoulement			Pression Différentielle			Temp. Fluide		Joint	Electrovannes PARKER LUCIFER®			Puissance		Groupe Electrique	N° Schéma
		Kv l/min	KV m³/h	Qn l/min	Min bar	Max AC bar	DC bar	Min °C	Max °C		Ref. Valve	Ref. Boîtier	Ref. Bobine	AC W	DC W		
3/4"	20	135	8.1	9300	0.3	16	16	-10	100	NBR	322G3610 ₁	2995	481865	8	9	2.1	3442
	20	135	8.1	9300	0.3	16	16	-10	100	NBR	322G3610 ₁	4270	481000	8	8	2.1	3442
1"	25	180	10.8	14000	0.3	16	16	-10	100	NBR	322G3710 ₁	2995	481865	8	9	2.1	3442
	25	180	10.8	14000	0.3	16	16	-10	100	NBR	322G3710 ₁	4270	481000	8	8	2.1	3442
1 1/4"	28	270	16.2	18000	0.3	16	16	-10	100	NBR	322G3810 ₁	2995	481865	8	9	2.1	3442
	28	270	16.2	18000	0.3	16	16	-10	100	NBR	322G3810 ₁	4270	481000	8	8	2.1	3442
1 1/2"	40	425	25.5	31000	0.3	12	12	-10	100	NBR	322G3910 ₁	2995	481865	8	9	2.1	3442
	40	425	25.5	31000	0.3	12	12	-10	100	NBR	322G3910 ₁	4270	481000	8	8	2.1	3442
2"	40	540	32.4	40000	0.3	12	12	-10	100	NBR	322G4010 ₁	2995	481865	8	9	2.1	3442
	40	540	32.4	40000	0.3	12	12	-10	100	NBR	322G4010 ₁	4270	481000	8	8	2.1	3442

Notes:

1. Avec vis de réglage du temps de fermeture (4 positions)



Dans cette page	Raccord	Orifice (mm)	Kv (l/min)	Pression Diff. Max. (bar)	Temp. Fluide (°C)	Temp. Amb. (°C)
de	3/4"	20	135	12	-10	-10
à	2"	40	540	16	100	50

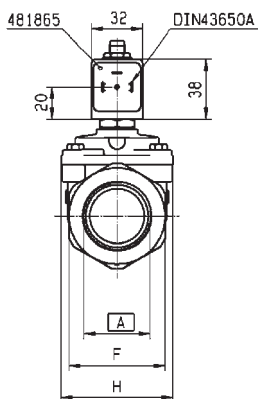
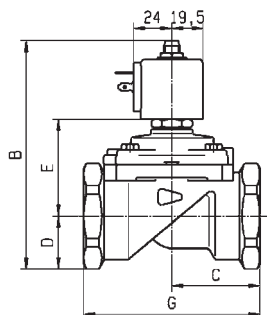

	RACCORD	A	B	C	D	E	F	G	H
321/322/E321G36	BSP 3/4"	121	50	23	54	41	100	70	
321/332/E321G37	BSP 1"	121	50	23	54	41	100	70	
321/332/E321G38	BSP 1 1/4"	137,5	55	33	60,5	60	110	70	
321/332/E321G39	BSP 1 1/2"	144	75	35	67	50	140	59	
321/336/E321G52	DNF 1 7/8"	144	75	33	67	60	140	59	
4321A/322G40	BSP 2"	158,5	80	41,5	73	75	150	99	

Schéma 3442

ELECTROVANNES POUR EAU CHAUDE ET VAPEUR



Vapeur



Eau

2/2

Commande	Corps de Valve	Fonction	Raccord	Orifice (mm)	Facteur d'Écoulement Kv(l/min)	Pression Différentielle (bar)	Temp. Max. Fluide (°C)	Page Valves Parker	Page Valves Parker LUCIFER®		
Commande Directe	Laiton/Raccord tuyau	Fermée hors tension	1/8"	2.5	3.2	30	140	126	-		
			1/4"	2.5 à 5	11	30	180	126	128		
			3/8"	6	12	5	140	-	128		
			1/2"	8.5 à 11	36	4	120	-	128		
Attraction forcée	Inox 303 /Raccord tuyau	Fermée hors tension	1/4"	1.5 à 5	10	100	180	-	130		
			Laiton/Raccord tuyau	Fermée hors tension	3/8"	15	65	10	140	-	132
					1/2"	15	65	10	140	-	132
					3/4"	15	80	10	140	-	132
Servo-commande	Laiton/Raccord tuyau	Fermée hors tension	1"	15	80	10	140	-	132		
			3/8"	10 à 16	78	16	180	134	-		
			1/2"	10 à 16	78	16	180	134	138		
			3/4"	18 à 27	193	14	180	136	-		
Servo-commande	Laiton/Raccord tuyau	Fermée hors tension	1"	18 à 27	193	14	180	136	-		



Equipement Commercial



Equipement Industriel



Médical / Instrumentation

LAITON RACCORD TUYAU

FERMÉE HORS TENSION

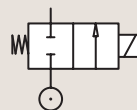

Raccord BSP	Orifice Ø mm	Facteur d'Écoulement			Pression Différentielle			Temp. Fluide		Joint	Electrovalves PARKER			Puissance		Groupe Electrique	N° Schéma
		Kv l/min	KV m³/h	Qn m³/h	Min bar	Max AC bar	DC bar	Min °C	Max °C		N° Commande Valve	Type de Valve	Type de Bobine	AC W	DC W		
1/8"	2.5	3.2	0.192	-	0	30	-	-30	140	Ruby	362496J	PM140IR	ZB09	9	-	20.1/20.2	027
	2.5	3.2	0.192	-	0	-	17	-30	140	Ruby	362496J	PM140IR	ZB12	-	12	20.1/20.2	027
1/4"	2.5	3.2	0.192	-	0	30	-	-30	140	Ruby	362518J ₂	PM140CR	ZB09	9	-	20.1/20.2	026
	2.5	3.2	0.192	-	0	-	17	-30	140	Ruby	362518J ₂	PM140CR	ZB12	-	12	20.1/20.2	026
	2.5	3.2	0.192	-	0	30	-	-30	140	Ruby	362518J ₂	PM140CR	ZH14	14	-	20.1/20.2	026
	2.5	3.2	0.192	-	0	-	17	-30	140	Ruby	362518J ₂	PM140CR	ZH16	-	16	20.1/20.2	026
	3	4.2	0.25	-	0	10	-	-10	140	EPDM	360470 ₁	PM126YH	ZB09	9	-	20.1/20.2	008
	3	4.2	0.25	-	0	-	6	-10	140	EPDM	360470 ₁	PM126YH	ZB12	-	12	20.1/20.2	008
	3	4.2	0.25	-	0	10	-	-10	140	EPDM	360470 ₁	PM126YH	ZH14	14	-	20.1/20.2	008
	3	4.2	0.25	-	0	-	6	-10	140	EPDM	360470 ₁	PM126YH	ZH16	-	16	20.1/20.2	008
	3	4.2	0.25	-	0	10	-	-10	180	PTFE	360475 ₁	PM126YT	ZH14	14	-	20.1/20.2	008
	3	4.2	0.25	-	0	-	10	-10	180	PTFE	360475 ₁	PM126YT	ZH16	-	16	20.1/20.2	008
	3	4	0.24	-	0	30	-	-30	140	Ruby	362524J	PM140DR	ZB09	9	-	20.1/20.2	026
	3	4	0.24	-	0	-	12	-30	140	Ruby	362524J	PM140DR	ZB12	-	12	20.1/20.2	026
	3	4	0.24	-	0	30	-	-30	140	Ruby	362524J	PM140DR	ZH14	14	-	20.1/20.2	026
	3	4	0.24	-	0	-	12	-30	140	Ruby	362524J	PM140DR	ZH16	-	16	20.1/20.2	026
	3	3.3	0.2	-	0	10	-	-10	140	EPDM	364880J ₁	PM158IH	ZH14	14	-	20.2	042
	3	3.3	0.2	-	0	-	4	-10	140	EPDM	364880J ₁	PM158IH	ZH16	-	16	20.2	042
3	3.3	0.2	-	0	10	-	-10	180	PTFE	364884J ₁	PM158IT	ZH14	14	-	20.2	042	
3	3.3	0.2	-	0	-	10	-10	180	PTFE	364884J ₁	PM158IT	ZH16	-	16	20.2	042	

Notes:

- 1.Pression Max pour la vapeur : 4 Bar (140°C)
- 2.Selon DIN-EN-ISO 23553-1 (2009-10) pour brûleur à fuel



Dans cette page	Raccord	Orifice (mm)	Kv (l/min)	Pression Diff. Max. (bar)	Temp. Fluide (°C)	Temp. Amb. (°C)
de	1/8"	2.5	3.2	4	-30	-10
à	1/4"	3	4.2	30	180	50



Schéma 027



Schéma 026

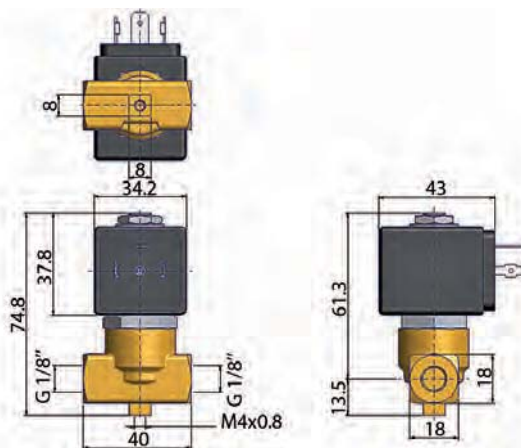

Schéma 008

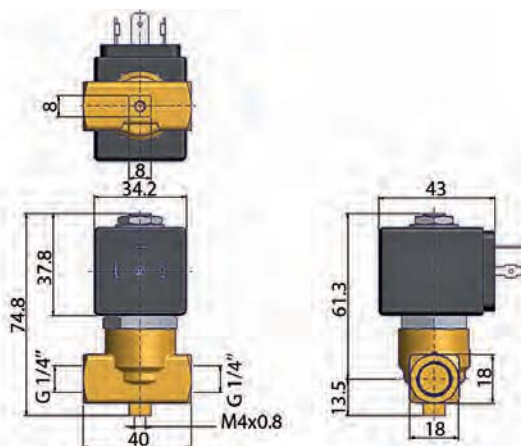

Schéma 042

2/2

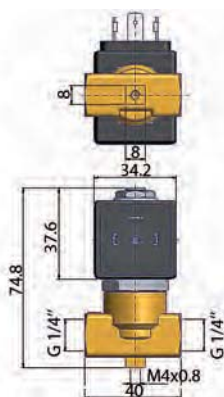
ELECTROVANNES POUR EAU CHAUDE ET VAPEUR COMMANDE DIRECTE

LAITON

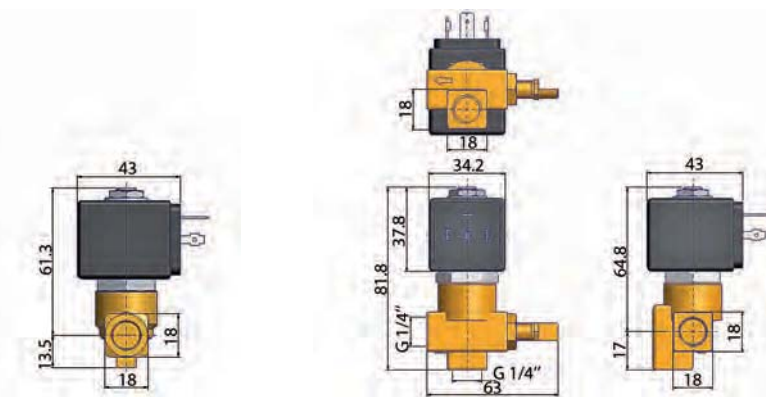
RACCORD TUYAU

FERMÉE HORS TENSION

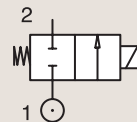

Raccord BSP	Orifice Ø mm	Facteur d'Écoulement			Pression Différentielle			Temp. Fluide		Joint	Electrovannes PARKER LUCIFER®			Puissance		Groupe Électrique	N° Schéma
		Kv l/min	KV m³/h	Qn l/min	Min bar	Max AC bar	Max DC bar	Min °C	Max °C		Ref. Valve	Ref. Boîtier	Ref. Bobine	AC W	DC W		
1/4"	3	4.5	0.27	-	0	10	7	0	100	EPDM	121K0323	2995	481865	8	9	2.0	3510
	3	4.5	0.27	-	0	10	8.5	-	120	EPDM	121K0323	4270	481000	8	8	2.0	3510
	3	4.5	0.27	-	0	10	10	0	120	EPDM	121K0323	4270	486265	14	14	2.0	3510
	3	4.5	0.27	-	0	10	10	0	120	EPDM	121K0323	2995	492425	14	14	2.0	3510
	5	11	0.66	750	0	7	2	0	100	EPDM	121K0103	2995	481865	8	9	2.0	3510
	5	11	0.66	750	0	7	2.8	0	120	EPDM	121K0103	4270	481000	8	8	2.0	3510
	5	11	0.66	750	0	7	5	0	120	EPDM	121K0103	4270	486265	14	14	2.0	3510
	5	11	0.66	750	0	4	3.5	0	120	EPDM	121K0103	2995	492425	14	14	2.0	3510
3/8"	5	11	0.66	750	0	7	2	0	100	EPDM	121K0113	2995	481865	8	9	2.0	3510
	6	12	0.72	1100	0	5	1.1	0	100	EPDM	121K3303	2995	481865	8	9	2.0	3551
	6	12	0.72	1100	0	5	1.5	0	120	EPDM	121K3303	4270	481000	8	8	2.0	3551
	6	12	0.72	1100	0	4	4	0	120	EPDM	121K3303	4270	486265	14	14	2.0	3551
1/2"	6	12	0.72	1100	0	4	4	0	140	EPDM	121K3303	2995	492425	14	14	2.0	3551
	8.5	25	1.5	-	0	2.2	0.5	0	120	EPDM	E121K4603	4270	481000	8	8	2.0	3427
	8.5	25	1.5	-	0	4	1.2	0	120	EPDM	E121K4603	4270	486265	14	14	2.0	3427
	8.5	25	1.5	-	0	4	1	0	120	EPDM	E121K4603	2995	492425	14	14	2.0	3427
	11	36	2.16	-	0	1.2	0.35	0	120	EPDM	E121K4503	4270	481000	8	8	2.0	3427
	11	36	2.16	-	0	2.5	0.7	0	120	EPDM	E121K4503	4270	486265	14	14	2.0	3427
11	36	2.16	-	0	2.5	0.5	0	120	EPDM	E121K4503	2995	492425	14	14	2.0	3427	



Dans cette page	Raccord	Orifice (mm)	Kv (l/min)	Pression Diff. Max. (bar)	Temp. Fluide (°C)	Temp. Amb. (°C)
de	1/4"	3	4.5	0.4	0	-10
à	1/2"	11	36	10	140	50



Schéma 3510



WEIGHT : 215 gr

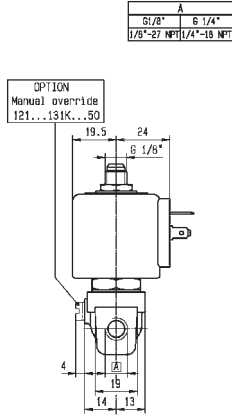
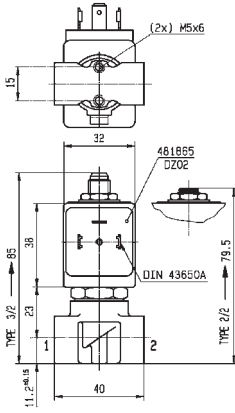
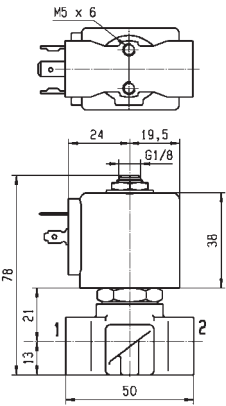

Schéma 3551



Schéma 3427

2/2

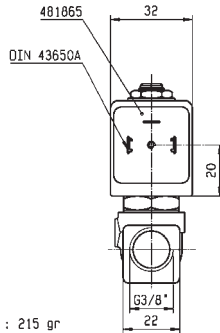
ELECTROVANNES POUR EAU CHAUDE ET VAPEUR COMMANDE DIRECTE

INOX 303

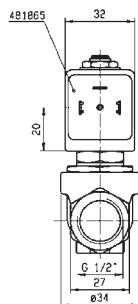
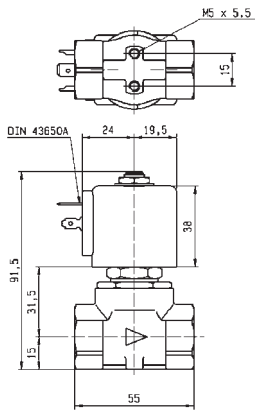
RACCORD TUYAU

FERMÉE HORS TENSION

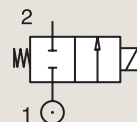

Raccord BSP	Orifice Ø mm	Facteur d'Écoulement			Pression Différentielle			Temp. Fluide		Joint	Electrovannes PARKER LUCIFER®			Puissance		Groupe Electrique	N° Schéma
		Kv l/min	KV m³/h	Qn l/min	Min bar	Max AC bar	Max DC bar	Min °C	Max °C		Ref. Valve	Ref. Boîtier	Ref. Bobine	AC W	DC W		
1/4"	1.5	1.5	0.09	80	0	60	25	0	100	Ruby	121V5463	2995	481865	8	9	2.0	8116
	1.5	1.5	0.09	80	0	75	30	0	130	Ruby	121V5463	4270	481000	8	8	2.0	8116
	1.5	1.5	0.09	80	0	100	55	0	140	Ruby	121V5463	4270	486265	14	14	2.0	8116
	2.5	3.5	0.21	220	0	28	10	0	100	Ruby	121V5763	2995	481865	8	9	2.0	8116
	2.5	3.5	0.21	220	0	34	12	0	130	Ruby	121V5763	4270	481000	8	8	2.0	8116
	2.5	3.5	0.21	220	0	50	22	0	140	Ruby	121V5763	4270	486265	14	14	2.0	8116
	3	4.5	0.27	315	0	20	7	0	100	Ruby	121V5363	2995	481865	8	9	2.0	8116
	3	4.5	0.27	315	0	25	8.5	0	130	Ruby	121V5363	4270	481000	8	8	2.0	8116
	3	4.5	0.27	315	0	36	15	0	140	Ruby	121V5363	4270	486265	14	14	2.0	8116
	4	7	0.42	450	0	12	4	0	100	Ruby	121V5263	2995	481865	8	9	2.0	8116
	4	7	0.42	450	0	15	5	0	130	Ruby	121V5263	4270	481000	8	8	2.0	8116
	4	7	0.42	450	0	22	10	0	180	Ruby	121V5263	4270	486265	14	14	2.0	8116
	5	10	0.6	750	0	8.5	2	0	100	Ruby	121V5163	2995	481865	8	9	2.0	8116
	5	10	0.6	750	0	10	3.5	0	130	Ruby	121V5163	4270	481000	8	8	2.0	8116
5	10	0.6	750	0	14	6.5	0	140	Ruby	121V5163	4270	486265	14	14	2.0	8116	



Dans cette page	Raccord	Orifice (mm)	Kv (l/min)	Pression Diff. Max. (bar)	Temp. Fluide (°C)	Temp. Amb. (°C)
de	1/4"	1.5	1.5	2	0	-10
à	1/4"	5	10	100	180	50

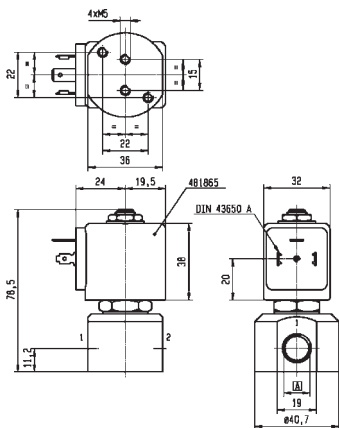

A	G 1/8"
	G 1/4"



Schéma 8116

2/2

ELECTROVANNES POUR EAU CHAUDE ET VAPEUR ATTRACTION FORCÉE



Equipement Commercial



Equipement Industriel



Médical / Instrumentation

LAITON RACCORD TUYAU

FERMÉE HORS TENSION

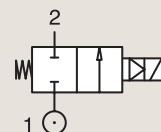

Raccord BSP	Orifice Ø mm	Facteur d'Écoulement			Pression Différentielle			Temp. Fluide		Joint	Electrovannes PARKER LUCIFER®			Puissance		Groupe Electrique	N° Schéma
		Kv l/min	KV m³/h	Qn l/min	Min bar	Max AC bar	DC bar	Min °C	Max °C		Ref. Valve	Ref. Boîtier	Ref. Bobine	AC W	DC W		
3/8"	15	65	3.9	-	0	10	-	0	100	EPDM	221G1303	2995	481865	8	-	2.0	3732
	15	65	3.9	-	0	10	-	0	120	EPDM	221G1303	4270	481000	8	-	2.0	3732
	15	65	3.9	-	0	4	4	0	140	EPDM	221G1303	4270	486265	14	14	2.0	3732
	15	65	3.9	4500	0	10	10	-10	100	FKM	221G1330 ₁	2995	481865	8	9	2.1	3732
	15	65	3.9	4500	0	10	10	-10	120	FKM	221G1330 ₁	-	492070	9	8	2.1	3732
	15	65	3.9	4500	0	10	10	-10	120	FKM	221G1330 ₁	-	492190	11	9	2.1	3732
1/2"	15	65	3.9	-	0	10	-	0	100	EPDM	221G1503	2995	481865	8	-	2.0	3732
	15	65	3.9	-	0	10	-	0	120	EPDM	221G1503	4270	481000	8	-	2.0	3732
	15	65	3.9	-	0	10	7	0	140	EPDM	221G1503	4270	486265	14	14	2.0	3732
3/4"	15	80	4.8	-	0	10	-	0	100	EPDM	221G1603	2995	481865	8	-	2.0	3444
	15	80	4.8	-	0	10	-	0	120	EPDM	221G1603	4270	481000	8	-	2.0	3444
	15	80	4.8	-	0	4	4	0	140	EPDM	221G1603	4270	486265	14	14	2.0	3444
1"	15	80	4.8	-	0	10	-	0	100	EPDM	221G1703	2995	481865	8	-	2.0	3445
	15	80	4.8	-	0	10	-	0	120	EPDM	221G1703	4270	481000	8	-	2.0	3445
	15	80	4.8	-	0	10	10	0	140	EPDM	221G1703	4270	486265	14	14	2.0	3445

Notes:

1. Tension continue uniquement (ou bobine avec pont redresseur)



Dans cette page	Raccord	Orifice (mm)	Kv (l/min)	Pression Diff. Max. (bar)	Temp. Fluide (°C)	Temp. Amb. (°C)
de	3/8"	15	65	4	-10	-10
à	1"	15	80	10	140	50



Schéma 3732



Schéma 3444

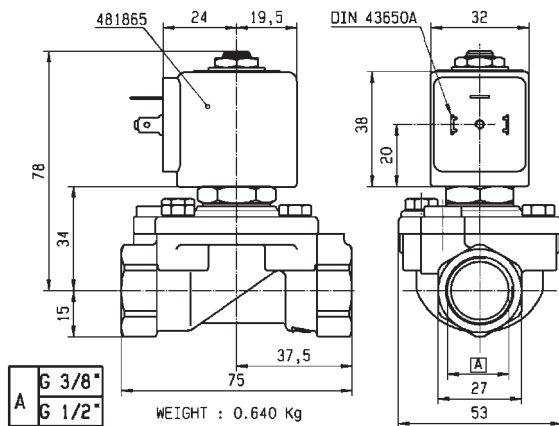

Schéma 3445

2/2

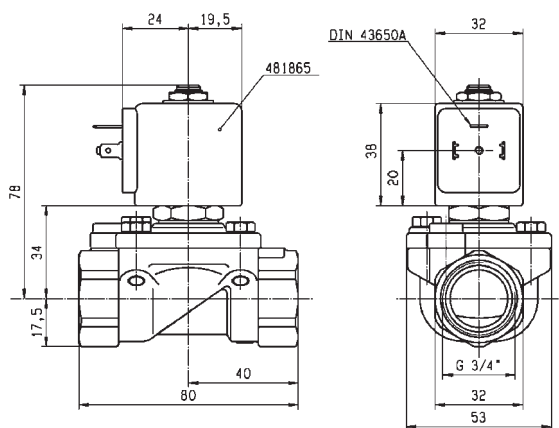
ELECTROVANNES POUR EAU CHAUDE ET VAPEUR SERVO-COMMANDE

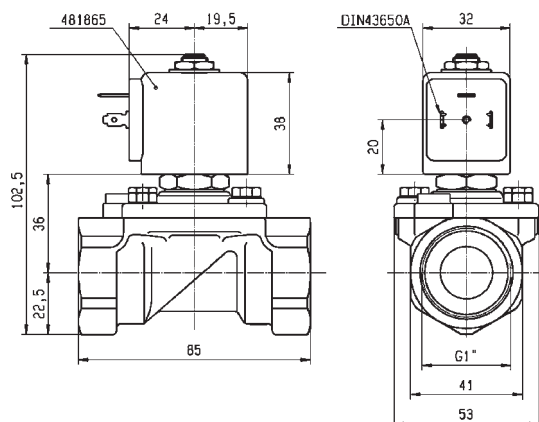

Equipement Commercial



Equipement Industriel



Médical / Instrumentation

LAITON RACCORD TUYAU

FERMÉE HORS TENSION

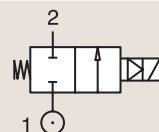

Raccord	Orifice Ø	Facteur d'Écoulement			Pression Différentielle			Temp. Fluide		Joint	Electrovannes PARKER			Puissance		Groupe Electrique	N° Schéma
											N° Commande Valve	Type de Valve	Type de Bobine				
BSP	mm	Kv l/min	KV m³/h	Qn m³/h	Min bar	Max AC bar	Max DC bar	Min °C	Max °C				AC W	DC W			
3/8"	10	22	1.32	-	0.5	16	-	-30	160	PTFE	364520 ₁	PM156.2IR	ZB09	9	-	20.1	041
	16	78	4.7	-	0.5	10	-	-30	180	PTFE	362262	PM135IT	ZH14	14	-	20.1/20.2	017
	16	78	4.7	-	0.5	-	10	-30	180	PTFE	362262	PM135IT	ZH16	-	16	20.1/20.2	017
1/2"	10	24	1.44	-	0.5	16	-	-30	160	PTFE	364525 ₁	PM156.2AR	ZB09	9	-	20.1	038
	16	78	4.7	-	0.5	10	-	-30	180	PTFE	362263	PM135AT	ZH14	14	-	20.1/20.2	016
	16	78	4.7	-	0.5	-	10	-30	180	PTFE	362263	PM135AT	ZH16	-	16	20.1/20.2	016

Notes:

1.Pression Max pour la vapeur : 6.5 Bar (160°C)



Dans cette page	Raccord	Orifice (mm)	Kv (l/min)	Pression Diff. Max. (bar)	Temp. Fluide (°C)	Temp. Amb. (°C)
de	3/8"	10	22	10	-30	-10
à	1/2"	16	78	16	180	50



Schéma 041



Schéma 017

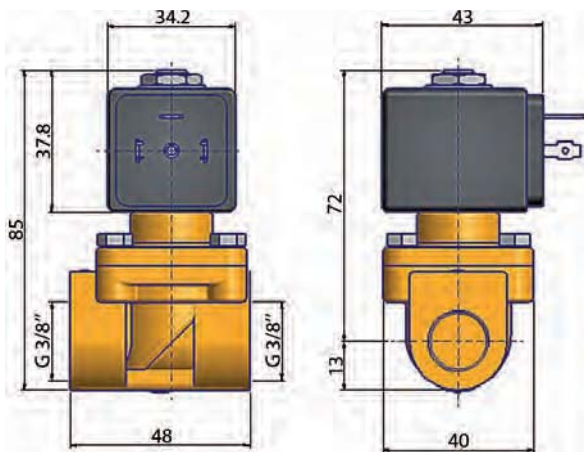

Schéma 038

Schéma 016

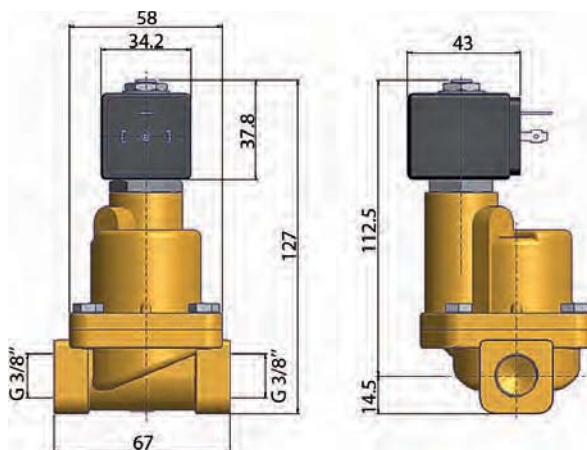
2/2

ELECTROVANNES POUR EAU CHAUDE ET VAPEUR SERVO-COMMANDE

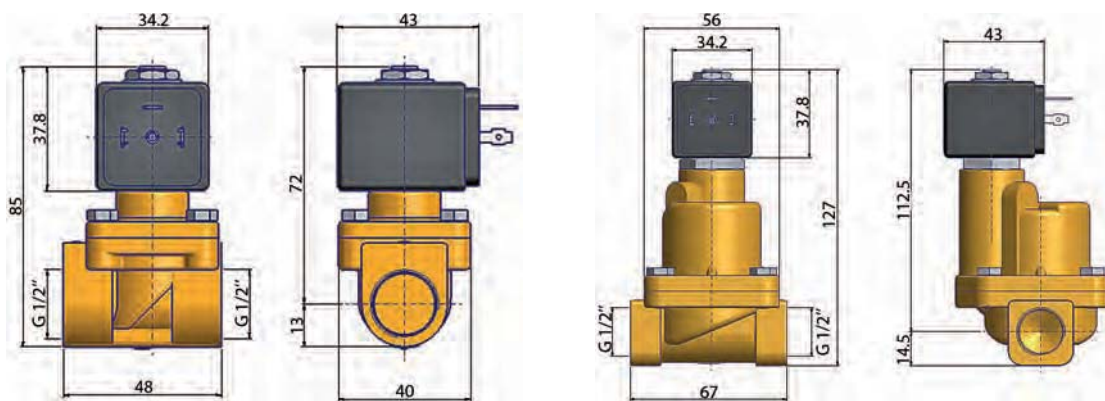
LAITON

RACCORD TUYAU

FERMÉE HORS TENSION

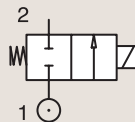

Raccord BSP	Orifice Ø mm	Facteur d'Écoulement			Pression Différentielle			Temp. Fluide		Joint	Electrovannes PARKER			Puissance		Groupe Electrique	N° Schéma
		Kv l/min	KV m³/h	Qn m³/h	Min bar	Max AC bar	DC bar	Min °C	Max °C		N° Commande Valve	Type de Valve	Type de Bobine	AC W	DC W		
3/4"	18	37	2.22	-	0.5	14	-	-30	160	PTFE	364530 ₁	PM156.2CR	ZB09	9	-	20.1	039
	27	193	11.6	-	0.5	10	-	-30	180	PTFE	362264	PM135CT	ZH14	14	-	20.1/20.2	018
	27	193	11.6	-	0.5	-	10	-30	180	PTFE	362264	PM135CT	ZH16	-	16	20.1/20.2	018
1"	18	42	2.52	-	0.5	14	-	-30	160	PTFE	364535 ₁	PM156.2DR	ZB09	9	-	20.1	040
	27	193	11.6	-	0.5	10	-	-30	180	PTFE	362265	PM135DT	ZH14	14	-	20.1/20.2	019
	27	193	11.6	-	0.5	-	10	-30	180	PTFE	362265	PM135DT	ZH16	-	16	20.1/20.2	019

Notes:

1.Pression Max pour la vapeur : 6.5 Bar (160°C)



Dans cette page	Raccord	Orifice (mm)	Kv (l/min)	Pression Diff. Max. (bar)	Temp. Fluide (°C)	Temp. Amb. (°C)
de	3/4"	18	37	10	-30	-10
à	1"	27	193	14	180	50



Schéma 039



Schéma 018

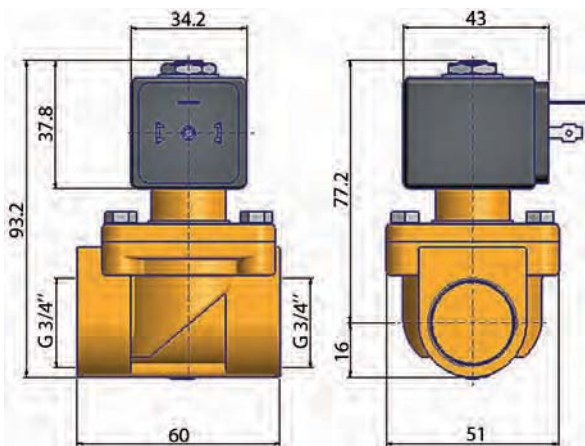

Schéma 040

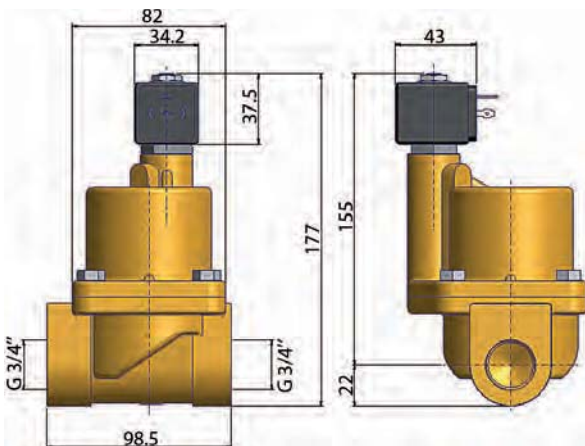

Schéma 019

2/2

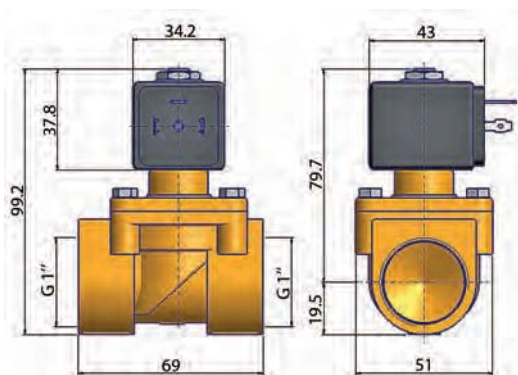
ELECTROVANNES POUR EAU CHAUDE ET VAPEUR SERVO-COMMANDE

LAITON

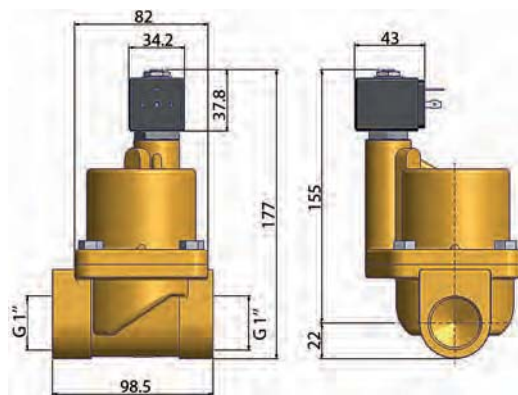
RACCORD TUYAU

FERMÉE HORS TENSION

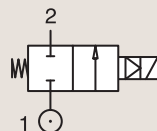

Raccord	Orifice Ø	Facteur d'écoulement			Pression Différentielle			Temp. Fluide		Joint	Electrovannes PARKER LUCIFER®			Puissance		Groupe Electrique	N° Schéma
					Min	Max		Min	Max		Ref. Valve	Ref. Boîtier	Ref. Bobine	AC W	DC W		
BSP	mm	Kv l/min	KV m³/h	Qn l/min	bar	AC bar	DC bar	°C	°C								
1/2"	11	36	2.16	-	0.2	10	4	0	120	EPDM	E321K1503	4270	481000	8	8	2.0	3427
	11	36	2.16	-	0.2	10	-	0	100	EPDM	E321K1503	4270	483520	9	-	2.0	3427
	11	36	2.16	-	0.2	10	-	0	120	EPDM	E321K1503	4270	486992	10	-	2.0	3427



Dans cette page	Raccord	Orifice (mm)	Kv (l/min)	Pression Diff. Max. (bar)	Temp. Fluide (°C)	Temp. Amb. (°C)
de	1/2"	11	36	4	0	-10
à	1/2"	11	36	10	120	50



Schéma 3427



ELECTROVANNES POUR HUILE HYDRAULIQUE
ET LIQUIDES NEUTRES (MAX. 100 BAR)

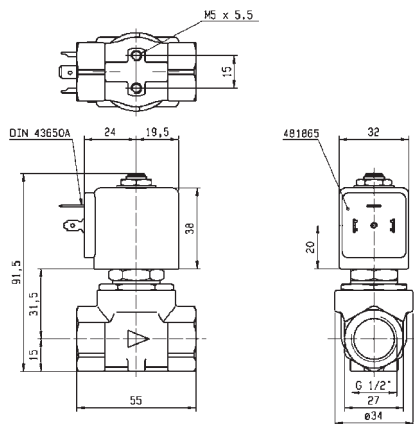

Huile



Eau

2/2

Commande	Corps de Valve	Fonction	Raccord	Orifice (mm)	Facteur d'Écoulement Kv(l/min)	MOPD (bar)	Temp. Fluide Max. (°C)	Page Valves Parker	Page Valves Parker LUCIFER®
Commande Directe	Laiton/Raccord tuyau	Fermée hors tension	1/8"	1.5 à 2.5	3.5	70	130	-	142
			1/4"	0.8 à 3	4.5	100	140	-	142
			3/8"	4 à 6	12	10	120	-	144
		Ouverte hors tension	1/8"	2.5	3.5	30	140	-	144
			1/4"	1.5 à 2.5	3.5	40	140	-	144
	Laiton/Montage sur embase	Fermée hors tension	5 mm	1.5 à 3	4.5	100	130	-	146
Servo-commande	Laiton/Raccord tuyau	Fermée hors tension	1/4"	8	36	40	140	-	148
			3/8"	11	50	40	140	-	148
			1/2"	15	60	40	140	-	150
		Ouverte hors tension	1/4"	8	36	40	140	-	152
			3/8"	11	50	40	140	-	152
			1/2"	15	60	40	140	-	152
			Laiton/Montage sur embase	Fermée hors tension	14 mm	14	45	40	140
		Ouverte hors tension	14 mm	14	45	40	120	-	154

2/2

ELECTROVANNES POUR HUILE HYDRAULIQUE ET LIQUIDES NEUTRES (MAX. 100 BAR) COMMANDE DIRECTE



Equipement Industriel



Equipement Commercial



Systèmes de Chauffage

LAITON RACCORD TUYAU

FERMÉE HORS TENSION

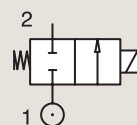

Raccord	Orifice Ø	Facteur d'Écoulement			Pression Différentielle			Temp. Fluide		Joint	Electrovannes PARKER LUCIFER®			Puissance		Groupe Electrique	N° Schéma
											Ref. Valve	Ref. Boîtier	Ref. Bobine	AC W	DC W		
BSP	mm	Kv l/min	KV m³/h	Qn l/min	Min bar	Max AC bar	DC bar	Min °C	Max °C								
1/8"	1.5	1.5	0.09	80	0	60	25	-30	75	PCTFE	E121K14	2995	481865	8	9	2.0	3510
	1.5	1.5	0.09	80	0	70	30	-30	75	PCTFE	E121K14	4270	481000	8	8	2.0	3510
	1.5	1.5	0.09	80	0	70	55	-30	75	PCTFE	E121K14	4270	486265	14	14	2.0	3510
	2.5	3.5	0.21	220	0	28	10	-30	100	Ruby	E121K23	2995	481865	8	9	2.0	3510
	2.5	3.5	0.21	220	0	34	12	-30	130	Ruby	E121K23	4270	481000	8	8	2.0	3510
	2.5	3.5	0.21	220	0	50	22	-30	120	Ruby	E121K23	4270	486265	14	14	2.0	3510
1/4"	1.2	0.85	0.051	50	0	80	36	-30	100	Ruby	E121K65	2995	481865	8	9	2.0	3510
	1.2	0.85	0.051	50	0	100	43	-30	130	Ruby	E121K65	4270	481000	8	8	2.0	3510
	1.2	0.85	0.051	50	0	100	75	-30	120	Ruby	E121K65	4270	486265	14	14	2.0	3510
	1.5	1.5	0.09	80	0	60	25	-30	75	PCTFE	E121K04	2995	481865	8	9	2.0	3510
	1.5	1.5	0.09	80	0	70	30	-30	75	PCTFE	E121K04	4270	481000	8	8	2.0	3510
	1.5	1.5	0.09	80	0	70	55	-30	75	PCTFE	E121K04	4270	486265	14	14	2.0	3510
	1.5	1.5	0.09	80	0	60	25	-30	100	Ruby	E121K67	2995	481865	8	9	2.0	3510
	1.5	1.5	0.09	80	0	75	30	-30	130	Ruby	E121K67	4270	481000	8	8	2.0	3510
	1.5	1.5	0.09	80	0	100	55	-30	120	Ruby	E121K67	4270	486265	14	14	2.0	3510
	2.5	3.5	0.21	220	0	28	10	-30	100	Ruby	E121K63	2995	481865	8	9	2.0	3510
	2.5	3.5	0.21	220	0	34	12	-30	130	Ruby	E121K63	4270	481000	8	8	2.0	3510
	2.5	3.5	0.21	220	0	50	22	-30	120	Ruby	E121K63	4270	486265	14	14	2.0	3510
	3	4.5	0.27	320	0	20	7	-30	75	PCTFE	E121K03	2995	481865	8	9	2.0/3.0	3510
	3	4.5	0.27	320	0	25	8.5	-30	75	PCTFE	E121K03	4270	481000	8	8	2.0/3.0	3510



Dans cette page	Raccord	Orifice (mm)	Kv (l/min)	Pression Diff. Max. (bar)	Temp. Fluide (°C)	Temp. Amb. (°C)
de	1/8"	1.2	0.85	7	-30	-10
à	1/4"	3	4.5	100	130	50



Schéma 3510

2/2

ELECTROVANNES POUR HUILE HYDRAULIQUE ET LIQUIDES NEUTRES (MAX. 100 BAR) COMMANDE DIRECTE

LAITON

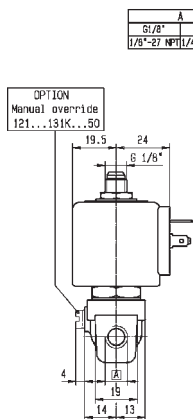
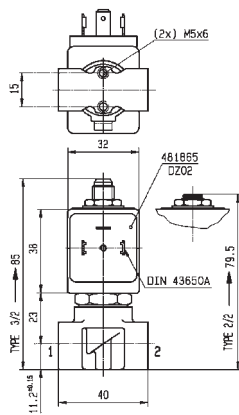
RACCORD TUYAU

FERMÉE HORS TENSION

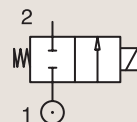

Raccord	Orifice Ø	Facteur d'Écoulement			Pression Différentielle			Temp. Fluide		Joint	Electrovannes PARKER LUCIFER®			Puissance		Groupe Electrique	N° Schéma
		Kv l/min	KV m³/h	Qn l/min	Min bar	Max AC bar	DC bar	Min °C	Max °C		Ref. Valve	Ref. Boîtier	Ref. Bobine	AC W	DC W		
1/4"	3	4.5	0.27	320	0	36	15	-30	75	PCTFE	E121K03	4270	486265	14	14	2.0/3.0	3510
	3	4.5	0.27	320	0	20	7	-30	100	Ruby	E121K64	2995	481865	8	9	2.0	3510
	3	4.5	0.27	320	0	25	8.5	-30	130	Ruby	E121K64	4270	481000	8	8	2.0	3510
	3	4.5	0.27	320	0	36	15	-30	120	Ruby	E121K64	4270	486265	14	14	2.0	3510
3/8"	4	7.5	0.45	480	0	10	4	-10	100	FKM	121K3206	2995	481865	8	9	2.0	3551
	4	7.5	0.45	480	0	10	5	-10	120	FKM	121K3206	4270	481000	8	8	2.0	3551
	4	7.5	0.45	480	0	10	10	-10	120	FKM	121K3206	4270	486265	14	14	2.0	3551
	5	11	0.66	750	0	7	2	-10	100	FKM	121K3106	2995	481865	8	9	2.0	3551
	5	11	0.66	750	0	7	2.8	-10	120	FKM	121K3106	4270	481000	8	8	2.0	3551
	5	11	0.66	750	0	7	5	-10	120	FKM	121K3106	4270	486265	14	14	2.0	3551
	6	12	0.72	1100	0	5	1.1	-10	100	FKM	121K3306	2995	481865	8	9	2.0/14.2	3551
	6	12	0.72	1100	0	5	1.5	-10	120	FKM	121K3306	4270	481000	8	8	2.0/14.2	3551
	6	12	0.72	1100	0	5	3	-10	120	FKM	121K3306	4270	486265	14	14	2.0/14.2	3551

LAITON

RACCORD TUYAU

OUVERTE HORS TENSION

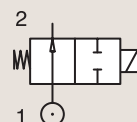

Raccord	Orifice Ø	Facteur d'Écoulement			Pression Différentielle			Temp. Fluide		Joint	Electrovannes PARKER LUCIFER®			Puissance		Groupe Electrique	N° Schéma
		Kv l/min	KV m³/h	Qn l/min	Min bar	Max AC bar	DC bar	Min °C	Max °C		Ref. Valve	Ref. Boîtier	Ref. Bobine	AC W	DC W		
1/8"	2.5	3.5	0.21	-	0	30	-	-30	140	Ruby	122K9363	4270	481044	14	-	2.2	3510
	2.5	3.5	0.21	-	0	30	30	-30	140	Ruby	122K9363	4270	486265	14	14	2.2	3510
1/4"	1.5	1.5	0.09	9.6	0	30	30	-10	100	PCTFE	122K84	2995	481865	8	9	2.1	3510
	1.5	1.5	0.09	9.6	0	30	30	-10	100	PCTFE	122K84	4270	481000	8	8	2.1	3510
	1.5	1.5	0.09	9.6	0	30	30	-10	120	PCTFE	122K84	4270	486265	14	14	2.1	3510
	1.5	1.5	0.09	80	0	40	40	-30	100	Ruby	122K8408	2995	481865	8	9	2.1	3510
	1.5	1.5	0.09	80	0	40	40	-30	130	Ruby	122K8408	4270	481000	8	8	2.1	3510
	1.5	1.5	0.09	80	0	40	40	-30	130	Ruby	122K8408	4270	486265	14	14	2.0	3510
	2.5	3.5	0.21	-	0	30	-	-30	140	Ruby	122K8363	4270	481044	14	-	2.2	3510
	2.5	3.5	0.21	-	0	30	30	-30	140	Ruby	122K8363	4270	486265	14	14	2.2	3510

2/2

ELECTROVANNES POUR HUILE HYDRAULIQUE ET LIQUIDES NEUTRES (MAX. 100 BAR) COMMANDE DIRECTE

LAITON

MONTAGE SUR EMBASE

FERMÉE HORS TENSION

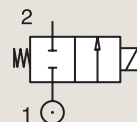

Raccord	Orifice Ø	Facteur d'Écoulement			Pression Différentielle			Temp. Fluide		Joint	Electrovannes PARKER LUCIFER®			Puissance		Groupe Électrique	N° Schéma
					Min bar	Max		Min °C	Max °C		Ref. Valve	Ref. Boîtier	Ref. Bobine	AC W	DC W		
						AC bar	DC bar										
SB	1.5	1.5	0.09	80	0	60	25	-30	100	Ruby	121F67	2995	481865	8	9	2.0	3509
	1.5	1.5	0.09	80	0	75	30	-30	130	Ruby	121F67	4270	481000	8	8	2.0	3509
	1.5	1.5	0.09	80	0	100	55	-30	120	Ruby	121F67	4270	486265	14	14	2.0	3509
	1.5	1.5	0.09	80	0	60	25	-30	75	PCTFE	E121F44	2995	481865	8	9	2.0	3509
	1.5	1.5	0.09	80	0	70	30	-30	75	PCTFE	E121F44	4270	481000	8	8	2.0	3509
	1.5	1.5	0.09	80	0	70	55	-30	75	PCTFE	E121F44	4270	486265	14	14	2.0	3509
	2.5	3.5	0.21	220	0	14	7	-10	100	FKM	121F4706	2995	481865	8	9	2.0	3509
	2.5	3.5	0.21	220	0	14	9	-10	120	FKM	121F4706	4270	481000	8	8	2.0	3509
	2.5	3.5	0.21	220	0	14	14	-10	120	FKM	121F4706	4270	486265	14	14	2.0	3509
	2.5	3.5	0.21	220	0	28	10	-30	100	Ruby	121F63	2995	481865	8	9	2.0	3509
	2.5	3.5	0.21	220	0	34	12	-30	130	Ruby	121F63	4270	481000	8	8	2.0	3509
	2.5	3.5	0.21	220	0	50	22	-30	120	Ruby	121F63	4270	486265	14	14	2.0	3509
	3	4.5	0.27	320	0	20	7	-30	100	Ruby	121F64	2995	481865	8	9	2.0	3509
	3	4.5	0.27	320	0	25	8.5	-30	130	Ruby	121F64	4270	481000	8	8	2.0	3509
	3	4.5	0.27	320	0	36	15	-30	120	Ruby	121F64	4270	486265	14	14	2.0	3509
	3	4.5	0.27	320	0	20	7	-30	75	PCTFE	E121F43	2995	481865	8	9	2.0	3509
	3	4.5	0.27	320	0	25	8.5	-30	75	PCTFE	E121F43	4270	481000	8	8	2.0	3509
	3	4.5	0.27	320	0	36	15	-30	75	PCTFE	E121F43	4270	486265	14	14	2.0	3509

2/2

ELECTROVANNES POUR HUILE HYDRAULIQUE ET LIQUIDES NEUTRES (MAX. 100 BAR) SERVO-COMMANDE



Equipement Commercial



Equipement Industriel



Systèmes de Chauffage

LAITON RACCORD TUYAU

FERMÉE HORS TENSION

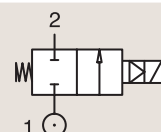

Raccord	Orifice Ø	Facteur d'Écoulement			Pression Différentielle			Temp. Fluide		Joint	Electrovannes PARKER LUCIFER®			Puissance		Groupe Electrique	N° Schéma
		Kv l/min	KV m³/h	Qn l/min	Min bar	Max AC bar	DC bar	Min °C	Max °C		Ref. Valve	Ref. Boîtier	Ref. Bobine	AC W	DC W		
1/4"	8	36	2.16	1600	0.3	40	25	-10	100	NBR	E321H11 ¹²³	2995	481865	8	9	2.0	3523
							30	-10	100	NBR	E321H11 ¹²³	4270	481000	8	8	2.0	3523
							40	-10	100	NBR	E321H11 ¹²³	4270	486265	14	14	2.0	3523
							25	-10	100	FKM	E321H21 ¹²³	2995	481865	8	9	2.0	3523
							30	-10	120	FKM	E321H21 ¹²³	4270	481000	8	8	2.0	3523
							40	-10	140	FKM	E321H21 ¹²³	4270	486265	14	14	2.0	3523
3/8"	11	50	3	2800	0.3	40	25	-10	100	NBR	E321H13 ¹²³	2995	481865	8	9	2.0	3521
							30	-10	100	NBR	E321H13 ¹²³	4270	481000	8	8	2.0	3521
							40	-10	100	NBR	E321H13 ¹²³	4270	486265	14	14	2.0	3521
							25	-10	100	FKM	E321H23 ¹²³	2995	481865	8	9	2.0	3521
							30	-10	120	FKM	E321H23 ¹²³	4270	481000	8	8	2.0	3521
							40	-10	140	FKM	E321H23 ¹²³	4270	486265	14	14	2.0	3521
							-	-10	100	Ruby	E321K63	2995	483510	9	-	2.0	3429
							-	-10	140	Ruby	E321K63	4270	488553	9	-	2.0	3429
4	-10	120	Ruby	E321K63	-	492190	11	9	2.0	3429							

Notes:

- Avec vis de réglage du temps de fermeture (4 positions)
- Joint du clapet de pilotage en rubis synthétique
- Pression différentielle min = 0.3 bar pour l'ouverture et 0 bar pour la fermeture



Dans cette page	Raccord	Orifice (mm)	Kv (l/min)	Pression Diff. Max. (bar)	Temp. Fluide (°C)	Temp. Amb. (°C)
de	1/4"	8	36	3	-10	-10
à	3/8"	11	50	40	140	50



Schéma 3523



Schéma 3521

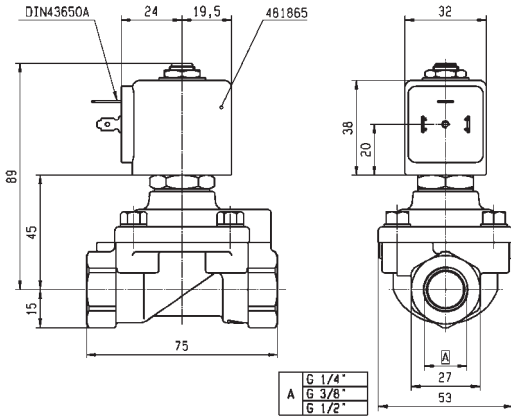

Schéma 3429

2/2

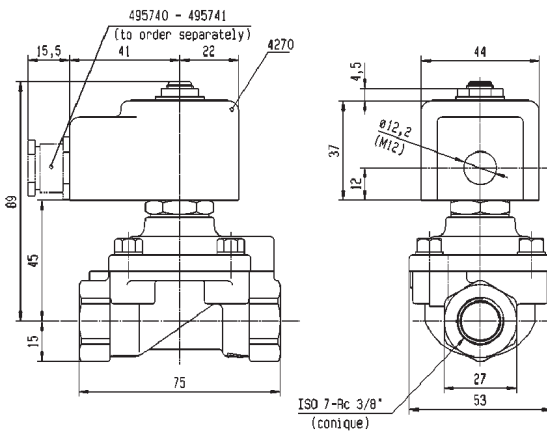
ELECTROVANNES POUR HUILE HYDRAULIQUE ET LIQUIDES NEUTRES (MAX. 100 BAR) SERVO-COMMANDE

LAITON

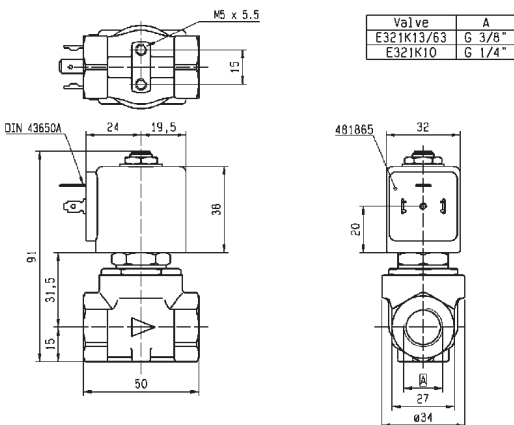
RACCORD TUYAU

FERMÉE HORS TENSION

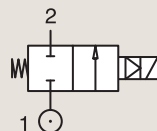

Raccord	Orifice Ø	Facteur d'Écoulement			Pression Différentielle			Temp. Fluide		Joint	Electrovannes PARKER LUCIFER®			Puissance		Groupe Electrique	N° Schéma
		Kv l/min	KV m³/h	Qn l/min	Min bar	Max AC bar DC bar		Min °C	Max °C		Ref. Valve	Ref. Boîtier	Ref. Bobine	AC W	DC W		
1/2"	15	60	3.6	3150	0.3	40	25	-10	100	NBR	E321H15 ₁₂₃	2995	481865	8	9	2.0	3522
	15	60	3.6	3150	0.3	40	30	-10	100	NBR	E321H15 ₁₂₃	4270	481000	8	8	2.0	3522
	15	60	3.6	3150	0.3	40	40	-10	100	NBR	E321H15 ₁₂₃	4270	486265	14	14	2.0	3522
	15	60	3.6	-	0.3	40	25	-10	100	FKM	E321H25 ₁₂₃	2995	481865	8	9	2.0/14.2	3522
	15	60	3.6	-	0.3	40	30	-10	120	FKM	E321H25 ₁₂₃	-	483371	8	8	2.0/14.2	3522
	15	60	3.6	-	0.3	40	40	-10	140	FKM	E321H25 ₁₂₃	4270	486265	14	14	2.0/14.2	3522

Notes:

1. Avec vis de réglage du temps de fermeture (4 positions)
2. Joint du clapet de pilotage en rubis synthétique
3. Pression différentielle min = 0.3 bar pour l'ouverture et 0 bar pour la fermeture



Dans cette page	Raccord	Orifice (mm)	Kv (l/min)	Pression Diff. Max. (bar)	Temp. Fluide (°C)	Temp. Amb. (°C)
de	1/2"	15	60	25	-10	-10
à	1/2"	15	60	40	140	50



Schéma 3522

2/2

ELECTROVANNES POUR HUILE HYDRAULIQUE ET LIQUIDES NEUTRES (MAX. 100 BAR) SERVO-COMMANDE

LAITON

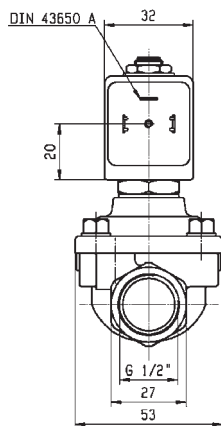
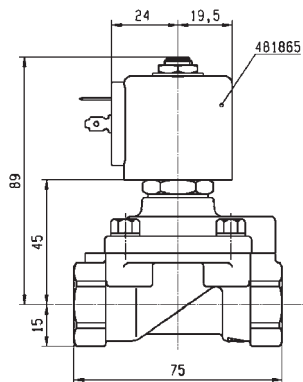
RACCORD TUYAU

OUVERTE HORS TENSION

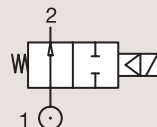

Raccord	Orifice Ø	Facteur d'Écoulement			Pression Différentielle			Temp. Fluide		Joint	Electrovannes PARKER LUCIFER®			Puissance		Groupe Électrique	N° Schéma
					Min	Max		Min	Max		Ref. Valve	Ref. Boîtier	Ref. Bobine	AC W	DC W		
BSP	mm	Kv l/min	KV m³/h	Qn l/min	bar	AC bar	DC bar	°C	°C								
1/4"	8	36	2.16	-	0.3	40	40	-10	100	FKM	322H7106 ₁₂₃	2995	481865	8	9	2.0/14.1	3523
	8	36	2.16	-	0.3	40	40	-10	120	FKM	322H7106 ₁₂₃	4270	481000	8	8	2.0/14.1	3523
	8	36	2.16	-	0.3	40	40	-10	140	FKM	322H7106 ₁₂₃	4270	486265	14	14	2.0/14.1	3523
3/8"	11	50	3	3240	0.3	40	40	-10	75	NBR	322H73 ₁₂₃	2995	481865	8	9	2.0	3523
	11	50	3	3240	0.3	40	40	-10	75	NBR	322H73 ₁₂₃	4270	481000	8	8	2.0	3523
	11	50	3	3240	0.3	40	40	-10	75	NBR	322H73 ₁₂₃	4270	486265	14	14	2.0	3523
	11	50	3	-	0.3	40	40	-10	100	FKM	322H7306 ₁₂₃	2995	481865	8	9	2.0/14.1	3523
	11	50	3	-	0.3	40	40	-10	100	FKM	322H7306 ₁₂₃	4270	481000	8	8	2.0/14.1	3523
	11	50	3	-	0.3	40	40	-10	140	FKM	322H7306 ₁₂₃	4270	486265	14	14	2.0/14.1	3523
1/2"	15	60	3.6	3890	0.3	20	20	-10	100	FKM	322G7506 ₃	2995	481865	8	9	2.0	3522
	15	60	3.6	3890	0.3	20	20	-10	100	FKM	322G7506 ₃	4270	481000	8	8	2.0	3522
	15	60	3.6	3890	0.3	20	20	-10	100	FKM	322G7506 ₃	4270	486265	14	14	2.0	3522
	15	60	3.6	3890	0.3	40	40	-10	100	NBR	322H75 ₁₂₃	2995	481865	8	9	2.0	3522
	15	60	3.6	3890	0.3	40	40	-10	100	NBR	322H75 ₁₂₃	4270	481000	8	8	2.0	3522
	15	60	3.6	3890	0.3	40	40	-10	100	NBR	322H75 ₁₂₃	4270	486265	14	14	2.0	3522
	15	60	3.6	-	0.3	40	40	-10	100	FKM	322H7506 ₁₂₃	2995	481865	8	9	2.0/14.1	3522
	15	60	3.6	-	0.3	40	40	-10	120	FKM	322H7506 ₁₂₃	4270	481000	8	8	2.0/14.1	3522
	15	60	3.6	-	0.3	40	40	-10	140	FKM	322H7506 ₁₂₃	4270	486265	14	14	2.0/14.1	3522

Notes:

- Avec vis de réglage du temps de fermeture (4 positions)
- Joint du clapet de pilotage en rubis synthétique
- Pression différentielle min = 0.3 bar pour l'ouverture et 0 bar pour la fermeture



Dans cette page	Raccord	Orifice (mm)	Kv (l/min)	Pression Diff. Max. (bar)	Temp. Fluide (°C)	Temp. Amb. (°C)
de	1/4"	8	36	20	-10	-10
à	1/2"	15	60	40	140	50



Schéma 3523



Schéma 3522

2/2

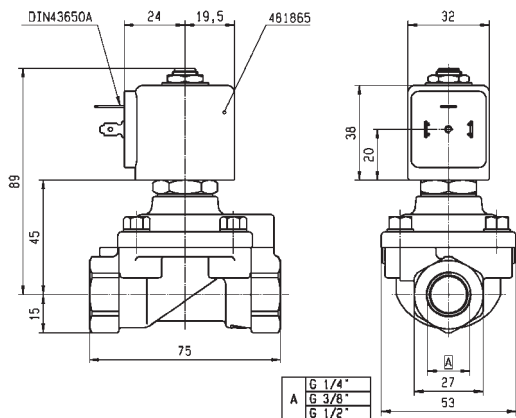
ELECTROVANNES POUR HUILE HYDRAULIQUE ET LIQUIDES NEUTRES (MAX. 100 BAR) SERVO-COMMANDE

LAITON

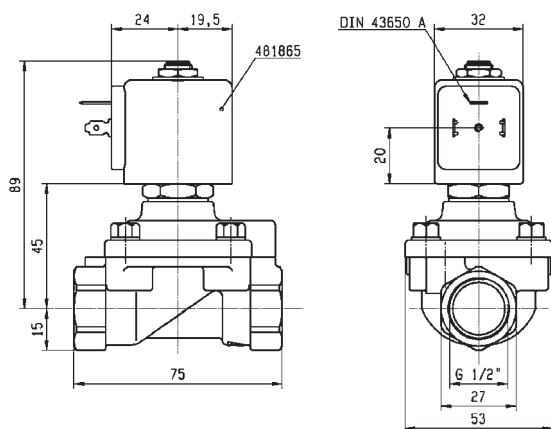
MONTAGE SUR EMBASE

FERMÉE HORS TENSION

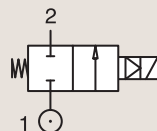

Raccord	Orifice Ø mm	Facteur d'Écoulement			Pression Différentielle			Temp. Fluide		Joint	Electrovannes PARKER LUCIFER®			Puissance		Groupe Électrique	N° Schéma
					Min bar	Max		Min °C	Max °C		Ref. Valve	Ref. Boîtier	Ref. Bobine	AC W	DC W		
						AC bar	DC bar										
SB	14	45	2.7	-	0.3	40	25	-10	100	FKM	E321F3202 ¹²³	2995	481865	8	9	2.0	3520
	14	45	2.7	-	0.3	40	30	-10	120	FKM	E321F3202 ¹²³	4270	481000	8	8	2.0	3520
	14	45	2.7	-	0.3	40	40	-10	140	FKM	E321F3202 ¹²³	4270	486265	14	14	2.0	3520

Notes:

- Avec vis de réglage du temps de fermeture (4 positions)
- Joint du clapet de pilotage en rubis synthétique
- Pression différentielle min = 0.3 bar pour l'ouverture et 0 bar pour la fermeture

LAITON

MONTAGE SUR EMBASE

OUVERTE HORS TENSION

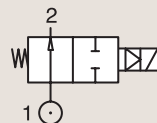

Raccord	Orifice Ø mm	Facteur d'Écoulement			Pression Différentielle			Temp. Fluide		Joint	Electrovannes PARKER LUCIFER®			Puissance		Groupe Électrique	N° Schéma
					Min bar	Max		Min °C	Max °C		Ref. Valve	Ref. Boîtier	Ref. Bobine	AC W	DC W		
						AC bar	DC bar										
SB	14	45	2.7	-	0.3	40	40	0	100	FKM	322F7206 ¹²³	2995	481865	8	9	2.1/14.1	3520
	14	45	2.7	-	0.3	40	40	0	120	FKM	322F7206 ¹²³	4270	481000	8	8	2.1/14.1	3520

Notes:

- Avec vis de réglage du temps de fermeture (4 positions)
- Joint du clapet de pilotage en rubis synthétique
- Pression différentielle min = 0.3 bar pour l'ouverture et 0 bar pour la fermeture



Dans cette page	Raccord	Orifice (mm)	Kv (l/min)	Pression Diff. Max. (bar)	Temp. Fluide (°C)	Temp. Amb. (°C)
de	SB	14	45	25	-10	-10
à	SB	14	45	40	140	50



Schéma 3520



ELECTROVANNES HAUTEMENT RESISTANTES A LA CORROSION (INOX 303)

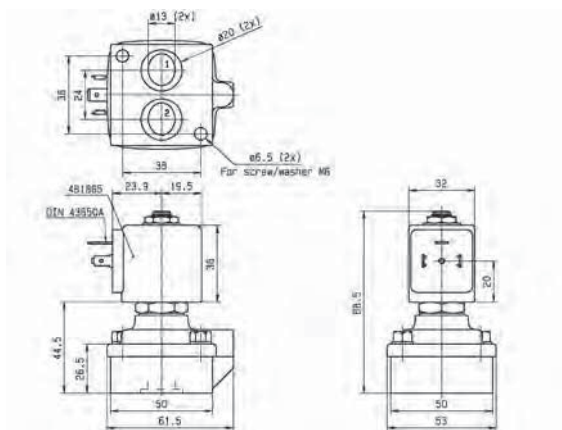

2/2

Commande	Corps de Valve	Fonction	Raccord	Orifice (mm)	Facteur d'Écoulement Kv(l/min)	Pression Différentielle (bar)	Temp. Max. Fluide (°C)	Page Valves Parker	Page Valves Parker LUCIFER®
Commande Directe	Inox 303 /Raccord tuyau	Fermée hors tension	1/4"	1.5 à 5	10	100	180	-	158
		Ouverte hors tension	1/4"	2.5	3	12	120	-	162

2/2

ELECTROVANNES HAUTEMENT RESISTANTES À LA CORROSION (INOX 303) COMMANDE DIRECTE



Process



Equipement Commercial

INOX 303

RACCORD TUYAU

FERMÉE HORS TENSION

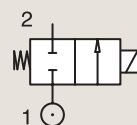

Raccord	Orifice Ø	Facteur d'Écoulement			Pression Différentielle			Temp. Fluide		Joint	Electrovannes PARKER LUCIFER®			IS	Puissance		Groupe Electrique	N° Schéma
					Min	Max		Min	Max		Ref. Valve	Ref. Boîtier	Ref. Bobine		AC W	DC W		
BSP	mm	Kv l/min	KV m³/h	Qn l/min	bar	AC bar	DC bar	°C	°C									
1/4"	1.5	1.5	0.09	80	0	20	20	-10	100	FKM	121V5406	2995	481865	8	9	2.0	8116	
	1.5	1.5	0.09	80	0	20	20	-10	120	FKM	121V5406	4270	481000	8	8	2.0	8116	
	1.5	1.5	0.09	80	0	60	25	0	100	Ruby	121V5463 ₁	2995	481865	8	9	2.0	8116	
	1.5	1.5	0.09	80	0	75	30	0	130	Ruby	121V5463 ₁	4270	481000	8	8	2.0	8116	
	1.5	1.5	0.09	80	0	100	55	0	140	Ruby	121V5463 ₁	4270	486265	14	14	2.0	8116	
	1.5	1.5	0.09	80	0	-	8	-20	75	PUR	121V5497 ₂	2995	482740	-	1.6	3.0/6.0/8.0	8024	
	1.5	1.5	0.09	80	0	10	10	-20	75	PUR	121V5497 ₂	-	495900	2.5	2	3.0/6.0/8.0	8024	
	1.5	1.5	0.09	80	0	-	10	-20	75	PUR	121V5497 ₂	-	495910	*	-	0.3 to 3	3.0/6.0/8.0	8024
	1.5	1.5	0.09	80	0	-	8	-20	75	PUR	121V5497 ₂	2995	496125	-	1.6	3.0/6.0/8.0	8024	
	2.5	3.5	0.21	220	0	14	7	-10	100	FKM	121V5706	2995	481865	8	9	2.0	8116	
	2.5	3.5	0.21	220	0	14	9	-10	120	FKM	121V5706	4270	481000	8	8	2.0	8116	
	2.5	3.5	0.21	220	0	14	14	-10	120	FKM	121V5706	4270	486265	14	14	2.0	8116	
	2.5	3.5	0.21	220	0	28	10	0	100	Ruby	121V5763 ₁	2995	481865	8	9	2.0	8116	
	2.5	3.5	0.21	220	0	34	12	0	130	Ruby	121V5763 ₁	4270	481000	8	8	2.0	8116	
	2.5	3.5	0.21	220	0	50	22	0	140	Ruby	121V5763 ₁	4270	486265	14	14	2.0	8116	
	3	4.5	0.27	315	0	10	7	-10	100	FKM	121V5306	2995	481865	8	9	2.0	8116	
	3	4.5	0.27	315	0	10	8.5	-10	120	FKM	121V5306	4270	481000	8	8	2.0	8116	
	3	4.5	0.27	315	0	10	10	-10	120	FKM	121V5306	4270	486265	14	14	2.0	8116	
	3	4.5	0.27	315	0	20	7	0	100	Ruby	121V5363 ₁	2995	481865	8	9	2.0	8116	
	3	4.5	0.27	315	0	25	8.5	0	130	Ruby	121V5363 ₁	4270	481000	8	8	2.0	8116	
3	4.5	0.27	315	0	36	15	0	140	Ruby	121V5363 ₁	4270	486265	14	14	2.0	8116		

Notes:

1. Valve uniquement compatible avec huile hydraulique et liquides neutres
2. Compatible avec l'eau uniquement jusqu'à 40°C



Dans cette page	Raccord	Orifice (mm)	Kv (l/min)	Pression Diff. Max. (bar)	Temp. Fluide (°C)	Temp. Amb. (°C)
de	1/4"	1.5	1.5	7	-20	-20
à	1/4"	3	4.5	100	180	50



Schéma 8116



Schéma 8024

2/2

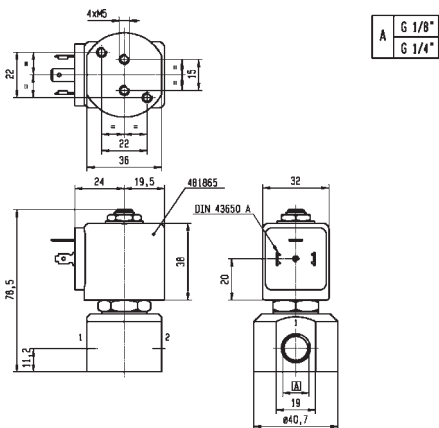
ELECTROVANNES HAUTEMENT RESISTANTES À LA CORROSION (INOX 303) COMMANDE DIRECTE

INOX 303

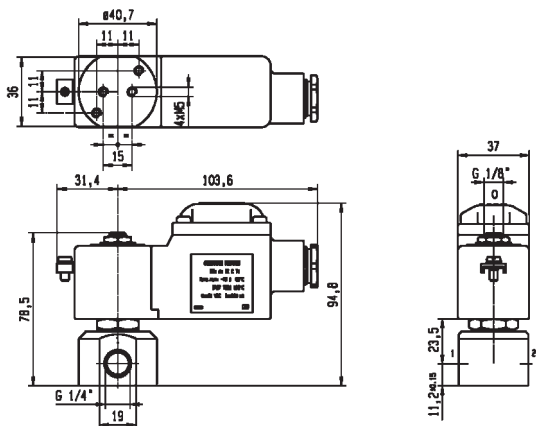
RACCORD TUYAU

FERMÉE HORS TENSION

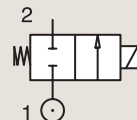

Raccord	Orifice Ø	Facteur d'Écoulement			Pression Différentielle		Temp. Fluide		Joint	Electrovannes PARKER LUCIFER®			IS	Puissance		Groupe Electrique	N° Schéma	
		Kv l/min	KV m³/h	Qn l/min	Min bar	Max AC bar	Max DC bar	Min °C		Max °C	Ref. Valve	Ref. Boîtier		Ref. Bobine	AC W			DC W
BSP	3	3.5	0.21	220	0	-	2	-20	75	PUR	121V5397 ₂	2995	482740	-	1.6	3.0/6.0/8.0	8024	
	3	3.5	0.21	220	0	4.5	4	-20	75	PUR	121V5397 ₂	-	495900	2.5	2	3.0/6.0/8.0	8024	
	3	3.5	0.21	220	0	-	4.5	-20	75	PUR	121V5397 ₂	-	495910	*	-	0.3 to 3	3.0/6.0/8.0	8024
	3	3.5	0.21	220	0	-	2	-20	75	PUR	121V5397 ₂	2995	496125	-	1.6	3.0/6.0/8.0	8024	
	4	7	0.42	450	0	10	4	-10	100	FKM	121V5206	2995	481865	8	9	2.0	8116	
	4	7	0.42	450	0	10	5	-10	120	FKM	121V5206	4270	481000	8	8	2.0	8116	
	4	7	0.42	450	0	10	10	-10	120	FKM	121V5206	4270	486265	14	14	2.0	8116	
	4	7	0.42	450	0	3.5	3.5	0	100	PTFE	121V5212 ₁	2995	481865	8	9	2.0	8116	
	4	7	0.42	450	0	3.5	3.5	0	130	PTFE	121V5212 ₁	4270	481000	8	8	2.0	8116	
	4	7	0.42	450	0	3.5	3.5	0	130	PTFE	121V5212 ₁	4270	486265	14	14	2.0	8116	
	1/4"	4	7	0.42	450	0	12	4	0	100	Ruby	121V5263 ₁	2995	481865	8	9	2.0	8116
		4	7	0.42	450	0	15	5	0	130	Ruby	121V5263 ₁	4270	481000	8	8	2.0	8116
4		7	0.42	450	0	22	10	0	180	Ruby	121V5263 ₁	4270	486265	14	14	2.0	8116	
5		10	0.6	750	0	7	2	-10	100	FKM	121V5106	2995	481865	8	9	2.0	8116	
5		10	0.6	750	0	7	2.8	-10	120	FKM	121V5106	4270	481000	8	8	2.0	8116	
5		10	0.6	750	0	7	5	-10	120	FKM	121V5106	4270	486265	14	14	2.0	8116	
5		10	0.6	-	0	2.8	2	0	100	PTFE	121V5112 ₁	2995	481865	8	9	2.0	8116	
5		10	0.6	-	0	2.8	2.8	0	130	PTFE	121V5112 ₁	4270	481000	8	8	2.0	8116	
5		10	0.6	-	0	2.8	2.8	0	130	PTFE	121V5112 ₁	4270	486265	14	14	2.0	8116	
5		10	0.6	750	0	8.5	2	0	100	Ruby	121V5163 ₁	2995	481865	8	9	2.0	8116	
5		10	0.6	750	0	10	3.5	0	130	Ruby	121V5163 ₁	4270	481000	8	8	2.0	8116	
5		10	0.6	750	0	14	6.5	0	140	Ruby	121V5163 ₁	4270	486265	14	14	2.0	8116	

Notes:

1. Valve uniquement compatible avec huile hydraulique et liquides neutres
2. Compatible avec l'eau uniquement jusqu'à 40°C



Dans cette page	Raccord	Orifice (mm)	Kv (l/min)	Pression Diff. Max. (bar)	Temp. Fluide (°C)	Temp. Amb. (°C)
de	1/4"	3	3.5	2	-20	-20
à	1/4"	5	10	22	180	50



Schéma 8024



Schéma 8116

2/2

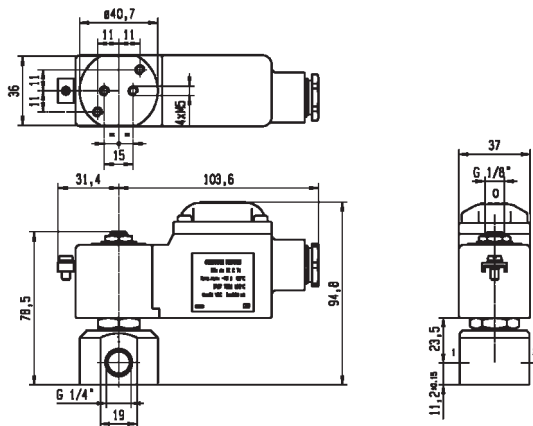
ELECTROVANNES HAUTEMENT RESISTANTES À LA CORROSION (INOX 303) COMMANDE DIRECTE

INOX 303

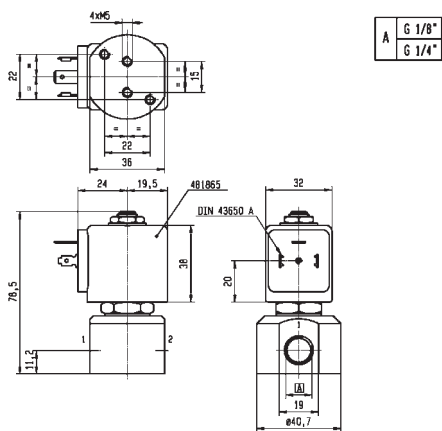
RACCORD TUYAU

OUVERTE HORS TENSION

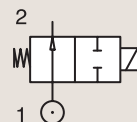

Raccord	Orifice Ø	Facteur d'Écoulement			Pression Différentielle			Temp. Fluide		Joint	Electrovannes PARKER LUCIFER®			Puissance		Groupe Electrique	N° Schéma	
		Kv l/min	KV m³/h	Qn l/min	Min bar	Max AC bar	Max DC bar	Min °C	Max °C		Ref. Valve	Ref. Boîtier	Ref. Bobine	AC W	DC W			
BSP	1/4"	2.5	3	0.18	180	0	12	12	-30	100	FKM	122V8306	2995	481865	8	9	2.1	8116
		2.5	3	0.18	180	0	12	12	-30	120	FKM	122V8306	4270	481000	8	8	2.1	8116



Dans cette page	Raccord	Orifice (mm)	Kv (l/min)	Pression Diff. Max. (bar)	Temp. Fluide (°C)	Temp. Amb. (°C)
de	1/4"	2.5	3	12	-30	-10
à	1/4"	2.5	3	12	120	50

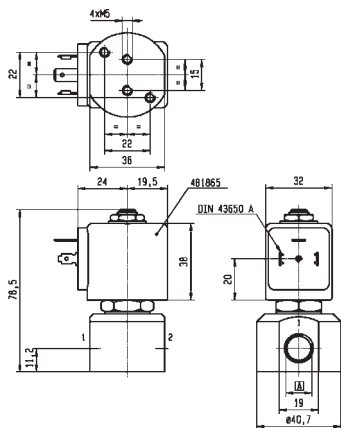

A	G 1/8"
	G 1/4"



Schéma 8116



ELECTROVANNES HAUTEMENT RESISTANTES A LA CORROSION (INOX 316L)



2/2

Commande	Corps de Valve	Fonction	Raccord	Orifice (mm)	Facteur d'Écoulement Kv(l/min)	Pression Différentielle (bar)	Temp. Max. Fluide (°C)	Page Valves Parker	Page Valves Parker LUCIFER®
Commande Directe	Inox 316L/Raccord tuyau	Fermée hors tension	1/4"	1.5 à 3.5	2.3	20	140	166	-
			1/8"	1.5 à 2.5	2.3	20	140	166	-
			1/2"	5 à 6.2	13	4	140	168	-
			3/8"	5 à 6.2	13	4	140	168	-
			1/4"	1	0.6	98	75	-	170
Attraction forcée	Inox 316L/Raccord tuyau	Fermée hors tension	1/2"	15	50	10	140	172	-
			3/4"	24	95	10	140	172	-
			3/8"	15	40	10	140	172	-
			1"	24	105	10	140	174	-

2/2

ELECTROVANNES HAUTEMENT RESISTANTES A LA CORROSION (INOX 316L) COMMANDE DIRECTE



Equipement Commercial



Médical / Instrumentation



Equipement Industriel

INOX 316L RACCORD TUYAU

FERMÉE HORS TENSION

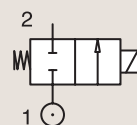

Raccord	Orifice Ø	Facteur d'Écoulement			Pression Différentielle			Temp. Fluide		Joint	Electrovannes PARKER			Puissance		Groupe Electrique	N° Schéma
					Min	Max		Min	Max		Ref. Valve	Ref. Boîtier	Ref. Bobine	AC W	DC W		
		bar	AC bar	DC bar	°C	°C											
BSP	mm	Kv l/min	KV m³/h	Qn l/min													
1/8"	1.5	1	0.06	-	0	20	-	-10	140	FKM	201LG1GVG2	-	WB4.5	4.5	-	1.1/1.3	074
	1.5	1	0.06	-	0	-	10	-10	140	FKM	201LG1GVG2	-	WB5.0	-	5	1.1/1.3	074
	2	1.8	0.11	-	0	15	-	-10	140	FKM	201LG1JVG2	-	WB4.5	4.5	-	1.1/1.3	074
	2	1.8	0.11	-	0	-	7	-10	140	FKM	201LG1JVG2	-	WB5.0	-	5	1.1/1.3	074
	2.5	2.3	0.14	-	0	10	-	-10	140	FKM	201LG1LVG2	-	WB4.5	4.5	-	1.1/1.3	074
	2.5	2.3	0.14	-	0	-	4	-10	140	FKM	201LG1LVG2	-	WB5.0	-	5	1.1/1.3	074
1/4"	1.5	1	0.06	-	0	20	-	-10	140	FKM	201LG2GVG2	-	WB4.5	4.5	-	1.1/1.3	075
	1.5	1	0.06	-	0	-	10	-10	140	FKM	201LG2GVG2	-	WB5.0	-	5	1.1/1.3	075
	2	1.8	0.11	-	0	15	-	-10	140	FKM	201LG2JVG2	-	WB4.5	4.5	-	1.1/1.3	075
	2	1.8	0.11	-	0	-	7	-10	140	FKM	201LG2JVG2	-	WB5.0	-	5	1.1/1.3	075
	2.5	2.3	0.14	-	0	10	-	-10	140	FKM	201LG2LVG2	-	WB4.5	4.5	-	1.1/1.3	075
	2.5	2.3	0.14	-	0	-	4	-10	140	FKM	201LG2LVG2	-	WB5.0	-	5	1.1/1.3	075
	3	0.5	0.027	-	0	8	8	-10	140	FKM	201LG2NVG7	-	481865	8	9	2.0	076
	3	0.5	0.027	-	0	10	11	-10	140	FKM	201LG2NVG7	-	491514	13	16	2.0	076
	3.5	0.6	0.036	-	0	6	6	-10	140	FKM	201LG2PVG7	-	481865	8	9	2.0	076
	3.5	0.6	0.036	-	0	7	8	-10	140	FKM	201LG2PVG7	-	491514	13	16	2.0	076



Dans cette page	Raccord	Orifice (mm)	Kv (l/min)	Pression Diff. Max. (bar)	Temp. Fluide (°C)	Temp. Amb. (°C)
de	1/8"	1.5	0.5	4	-10	-10
à	1/4"	3.5	2.3	20	140	50



Schéma 074



Schéma 075

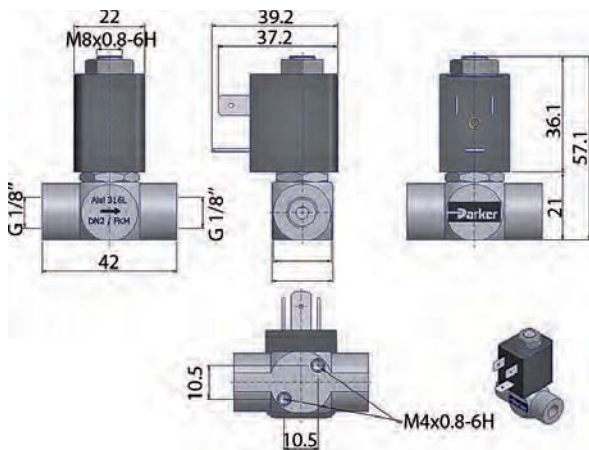

Schéma 076

2/2

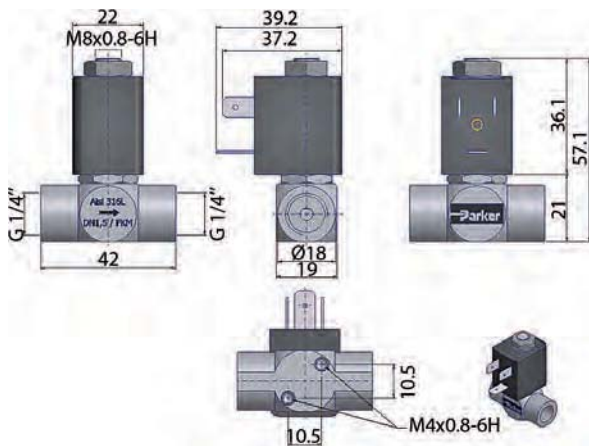
ELECTROVANNES HAUTEMENT RESISTANTES A LA CORROSION (INOX 316L) COMMANDE DIRECTE

INOX 316L

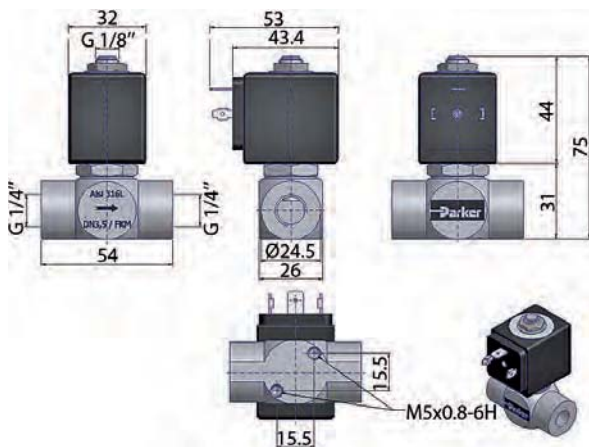
RACCORD TUYAU

FERMÉE HORS TENSION

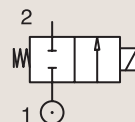

Raccord	Orifice Ø	Facteur d'Écoulement			Pression Différentielle			Temp. Fluide		Joint	Electrovannes PARKER			Puissance		Groupe Electrique	N° Schéma
		Kv l/min	KV m³/h	Qn l/min	Min bar	Max AC bar	Max DC bar	Min °C	Max °C		Ref. Valve	Ref. Boîtier	Ref. Bobine	AC W	DC W		
3/8"	5	11	0.66	-	0	3	3	-10	140	FKM	201LG3SVG7	-	481865	8	9	2.0	077
	5	11	0.66	-	0	4	4	-10	140	FKM	201LG3SVG7	-	491514	13	16	2.0	077
	6.2	13	0.78	-	0	2	2	-10	140	FKM	201LG3UVG7	-	481865	8	9	2.0	077
	6.2	13	0.78	-	0	2	3	-10	140	FKM	201LG3UVG7	-	491514	13	16	2.0	077
1/2"	5	11	0.66	-	0	3	3	-10	140	FKM	201LG4SVG7	-	481865	8	9	2.0	078
	5	11	0.66	-	0	4	4	-10	140	FKM	201LG4SVG7	-	491514	13	16	2.0	078
	6.2	13	0.78	-	0	2	2	-10	140	FKM	201LG4UVG7	-	481865	8	9	2.0	078
	6.2	13	0.78	-	0	2	3	-10	140	FKM	201LG4UVG7	-	491514	13	16	2.0	078



Dans cette page	Raccord	Orifice (mm)	Kv (l/min)	Pression Diff. Max. (bar)	Temp. Fluide (°C)	Temp. Amb. (°C)
de	3/8"	5	11	2	-10	-10
à	1/2"	6.2	13	4	140	50



Schéma 077



Schéma 078

2/2

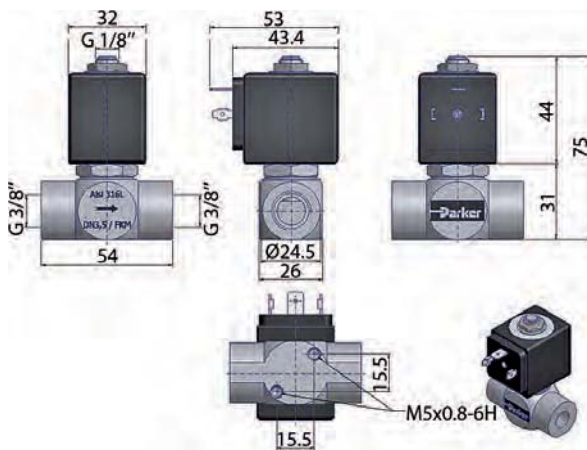
ELECTROVANNES HAUTEMENT RESISTANTE A LA CORROSION (INOX 316L) COMMANDE DIRECTE

INOX 316L

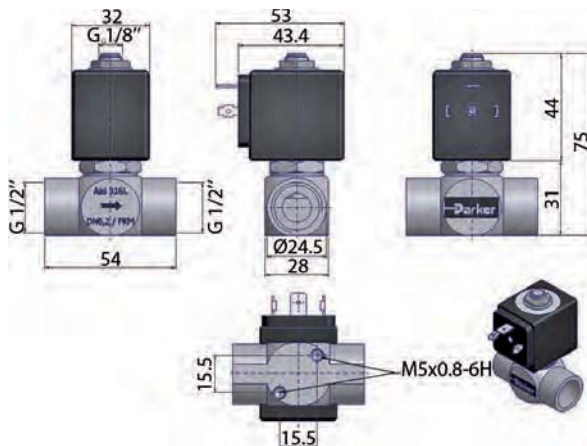
RACCORD TUYAU

FERMÉE HORS TENSION

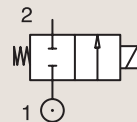

Raccord	Orifice Ø	Facteur d'Écoulement			Pression Différentielle			Temp. Fluide		Joint	Electrovannes PARKER LUCIFER®			IS	Puissance		Groupe Electrique	N° Schéma
		Kv l/min	KV m³/h	Qn l/min	Min bar	Max AC bar DC bar		Min °C	Max °C		Ref. Valve	Ref. Boîtier	Ref. Bobine		AC W	DC W		
1/4" NPT	1	0.6	0.036	40	0	-	98	-40	75	PUR	U121V5595 ₁	-	492210	-	1.8	9.0/10.1	6713	
	1	0.6	0.036	40	0	-	98	-40	75	PUR	U121V5595 ₁	-	496565	*	0.3	9.0/10.1	6713	
	1	0.6	0.036	40	0	98	98	-40	75	PUR	U121V5595 ₁	-	496800	8	8	9.0/10.1	6713	
	1	0.6	0.036	40	0	98	98	-40	75	PUR	U121V5595 ₁	-	496895	8	8	9.0/10.1	6713	
	1	0.6	0.036	40	0	98	98	-40	75	PUR	U121V5596 ₁	-	492310	6	6	10.1	6713	
	1	0.6	0.036	40	0	98	98	-40	75	PUR	U121V5596 ₁	-	496560	8	8	10.1	6713	
	1	0.6	0.036	40	0	98	98	-40	75	PUR	U121V5596 ₁	-	496800	8	8	10.1	6713	
	1	-	-	40	0	98	98	-10	75	PUR	U121V55961D ₁	-	483270	8	8	11.0	6714	
	1	-	-	40	0	98	98	-10	75	FKM	U121V55961D ₁	-	483270.02	8	8	11.0	6714	

Notes:

1.Valve livrée avec un certificat individuel de traçabilité matière



Dans cette page	Raccord	Orifice (mm)	Kv (l/min)	Pression Diff. Max. (bar)	Temp. Fluide (°C)	Temp. Amb. (°C)
de	1/4"	1	-	98	-40	-40
à	1/4"	1	0.6	98	75	50



Schéma 6713



Schéma 6714

2/2

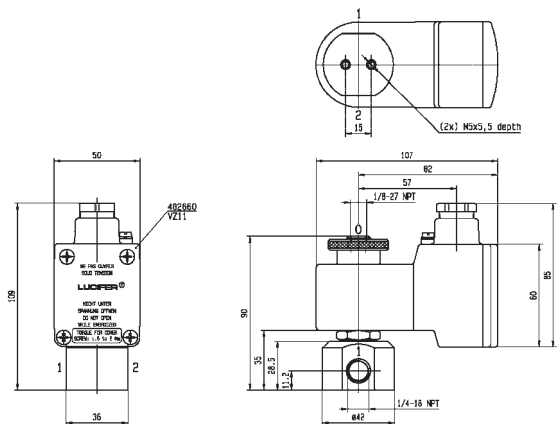
ELECTROVANNES HAUTEMENT RESISTANTES A LA CORROSION (INOX 316L) ATTRACTION FORCÉE

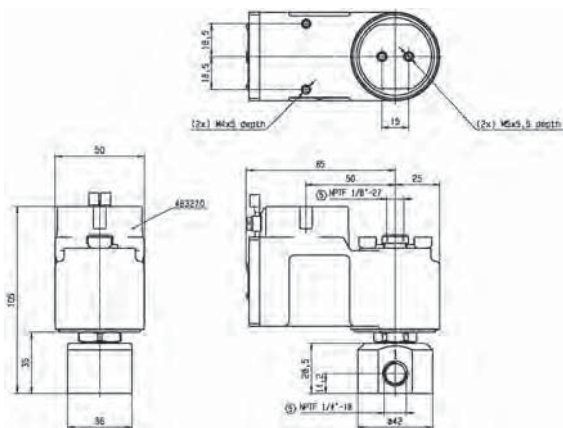

Equipement Commercial



Médical / Instrumentation



Equipement Industriel

INOX 316L RACCORD TUYAU

FERMÉE HORS TENSION

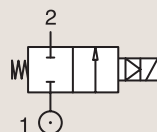

Raccord	Orifice Ø	Facteur d'Écoulement			Pression Différentielle			Temp. Fluide		Joint	Electrovannes PARKER			Puissance		Groupe Electrique	N° Schéma
		Kv l/min	KV m³/h	Qn l/min	Min bar	Max AC bar	DC bar	Min °C	Max °C		Ref. Valve	Ref. Boîtier	Ref. Bobine	AC W	DC W		
3/8"	15	40	2.4	-	0	10	-	-10	85	EPDM	221S10E	2995	481865	8	-	2.0	067
	15	40	2.4	-	0	10	7	-10	140	EPDM	221S10E ₁	4270	486265	14	14	2.0	067
	15	40	2.4	-	0	10	-	-10	85	FKM	221S10F	2995	481865	8	-	2.0	067
	15	40	2.4	-	0	10	7	-10	85	FKM	221S10F ₁	4270	486265	14	14	2.0	067
1/2"	15	50	3	-	0	10	-	-10	85	EPDM	221S15E	2995	481865	8	-	2.0	068
	15	50	3	-	0	10	7	-10	140	EPDM	221S15E ₁	4270	486265	14	14	2.0	068
	15	50	3	-	0	10	-	-10	85	FKM	221S15F	2995	481865	8	-	2.0	068
	15	50	3	-	0	10	7	-10	85	FKM	221S15F ₁	4270	486265	14	14	2.0	068
3/4"	24	95	5.7	-	0	10	-	-10	85	EPDM	221S20E	2995	481865	8	-	2.0	069
	24	95	5.7	-	0	10	7	-10	140	EPDM	221S20E ₁	4270	486265	14	14	2.0	069
	24	95	5.7	-	0	10	-	-10	85	FKM	221S20F	2995	481865	8	-	2.0	069
	24	95	5.7	-	0	10	7	-10	85	FKM	221S20F ₁	4270	486265	14	14	2.0	069

Notes:

1.Pression Max pour la vapeur : 4 Bar (140°C)



Dans cette page	Raccord	Orifice (mm)	Kv (l/min)	Pression Diff. Max. (bar)	Temp. Fluide (°C)	Temp. Amb. (°C)
de	3/8"	15	40	7	-10	-10
à	3/4"	24	95	10	140	50



Schéma 067



Schéma 068

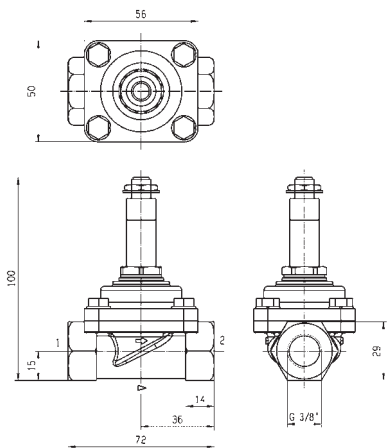

Schéma 069

2/2

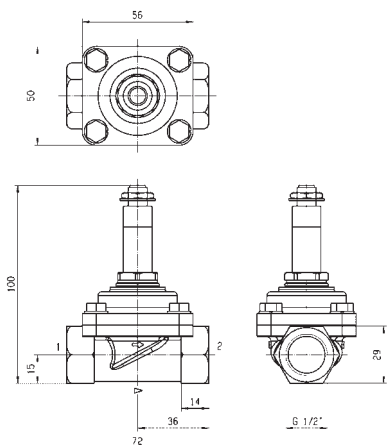
ELECTROVANNES HAUTEMENT RESISTANTES A LA CORROSION (INOX 316L) ATTRACTION FORCÉE

INOX 316L

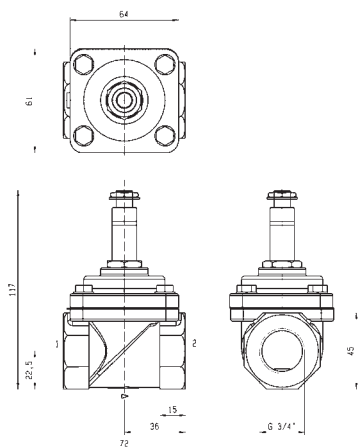
RACCORD TUYAU

FERMÉE HORS TENSION

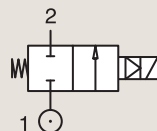

Raccord BSP	Orifice Ø mm	Facteur d'Écoulement			Pression Différentielle			Temp. Fluide		Joint	Electrovannes PARKER			Puissance		Groupe Electrique	N° Schéma
		Kv l/min	KV m³/h	Qn l/min	Min bar	Max AC bar	DC bar	Min °C	Max °C		Ref. Valve	Ref. Boîtier	Ref. Bobine	AC W	DC W		
1"	24	105	6.3	-	0	10	-	-10	85	EPDM	221S25E	2995	481865	8	-	2.0	070
	24	105	6.3	-	0	10	7	-10	140	EPDM	221S25E ₁	4270	486265	14	14	2.0	070
	24	105	6.3	-	0	10	-	-10	85	FKM	221S25F	2995	481865	8	-	2.0	070
	24	105	6.3	-	0	10	7	-10	85	FKM	221S25F ₁	4270	486265	14	14	2.0	070

Notes:

1.Pression Max pour la vapeur : 4 Bar (140°C)



Dans cette page	Raccord	Orifice (mm)	Kv (l/min)	Pression Diff. Max. (bar)	Temp. Fluide (°C)	Temp. Amb. (°C)
de	1"	24	105	7	-10	-10
à	1"	24	105	10	140	50



Schéma 070

ELECTROVANNES POUR BRÛLEUR A FUEL

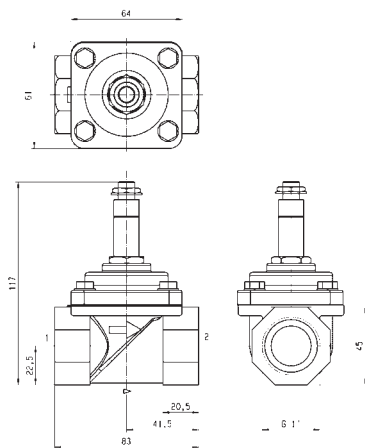

2/2

Commande	Corps de Valve	Fonction	Raccord	Orifice (mm)	Facteur d'Écoulement Kv(l/min)	Pression Différentielle (bar)	Temp. Max. Fluide (°C)	Page Valves Parker	Page Valves Parker LUCIFER®
Commande Directe	Laiton/Raccord tuyau	Fermée hors tension	1/8"	1.7 à 4	5.3	30	160	178	184
			1/4"	2.5 à 4	6.5	30	160	180	184
			3/8"	5 à 11	22	30	160	182	184
			1/2"	5 à 14	25	30	160	182	184
	Laiton/Raccord tuyau	Ouverte hors tension	1/8"	2.5 à 3	4	30	160	186	188
			1/4"	2.5 à 3	4	30	160	186	188
Laiton/Montage sur embase	Fermée hors tension	14 mm	14	25	30	160	-	188	
Attraction forcée	Laiton/Raccord tuyau	Fermée hors tension	1/2"	15	50	5	140	-	190
Servo-commande	Laiton/Raccord tuyau	Fermée hors tension	1/4"	8	36	40	140	-	192
			3/8"	11	50	40	160	-	192
			1/2"	15	60	40	160	-	194
Servo-commande	Laiton/Montage sur embase	Fermée hors tension	14 mm	14	45	30	160	-	194



Systèmes de Chauffage



Equipement Commercial

LAITON RACCORD TUYAU

FERMÉE HORS TENSION

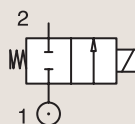

Raccord	Orifice Ø	Facteur d'Écoulement			Pression Différentielle			Temp. Fluide		Joint	Electrovannes PARKER			Puissance		Groupe Electrique	N° Schéma
		Kv l/min	KV m³/h	Qn m³/h	Min bar	Max AC bar	DC bar	Min °C	Max °C		N° Commande Valve	Type de Valve	Type de Bobine	AC W	DC W		
BSP	1.7	1.4	0.086	-	0	25	-	-10	90	NBR	390034 ₁	131IN	KT09 110-120/60	9	-	22.0	015
	1.7	1.4	0.086	-	0	25	-	-10	90	NBR	390085 ₁	131IN	KT09 208-230/60	9	-	22.0	015
	1.7	1.4	0.086	-	0	25	-	-10	90	NBR	390005 ₁	131IN	KT09 24/50	9	-	22.0	015
	1.7	1.4	0.086	-	0	-	22	-10	90	NBR	390120 ₁	131IN	KT10 24 DC	-	10	22.0	015
	1.7	1.4	0.086	-	0	25	-	-10	90	NBR	390300 ₁₂	131INDIN	XT09 230/50	9	-	22.0	015
	1.7	1.4	0.086	-	0	25	-	-10	90	FKM	390086 ₁	131IV	KT09 208-230/60	9	-	22.0	015
	1.7	1.4	0.086	-	0	25	-	-10	90	FKM	390088 ₁₂	131IV	KT09 230/50	9	-	22.0	015
	1.7	1.4	0.086	-	0	25	-	-10	90	FKM	390089 ₁	131IV	KT09 240/50	9	-	22.0	015
	2.2	2	0.12	-	0	15	-	-10	90	NBR	390216 ₁	131AN	KT09 208-230/60	9	-	22.0	015
	2.2	2	0.12	-	0	15	-	-10	90	NBR	390165 ₁	131AN	KT09 230/50	9	-	22.0	015
	2.2	2	0.12	-	0	15	-	-10	90	NBR	390145 ₁	131AN	KT09 24/50	9	-	22.0	015
	1/8"	2.2	2	0.12	-	0	15	-	-10	90	NBR	390150 ₁	131AN	KT09 42/50	9	-	22.0
2.2		2	0.12	-	0	-	13	-10	90	NBR	390195 ₁	131AN	KT10 12 DC	-	10	22.0	015
2.2		2	0.12	-	0	-	13	-10	90	NBR	390215 ₁	131AN	KT10 24 DC	-	10	22.0	015
2.5		3.2	0.192	-	0	30	-	-30	140	Ruby	362496J	PM140IR	ZB09	9	-	20.1/20.2	027
2.5		3.2	0.192	-	0	-	17	-30	140	Ruby	362496J	PM140IR	ZB12	-	12	20.1/20.2	027
2.8		2.9	0.174	-	0	8	-	-10	140	FKM	390445 ₁	131.4BV	KT09 115/50	9	-	22.0	012
2.8		2.9	0.174	-	0	8	-	-10	140	FKM	390457 ₁	131.4BV	KT09 115/60	9	-	22.0	012
2.8		2.9	0.174	-	0	8	-	-10	140	FKM	390458 ₁	131.4BV	KT09 208-230/60	9	-	22.0	012
2.8		2.9	0.174	-	0	8	-	-10	140	FKM	390465 ₁	131.4BV	KT09 230/50	9	-	22.0	012
2.8		2.9	0.174	-	0	8	-	-10	140	FKM	390405 ₁	131.4BV	KT09 24/50	9	-	22.0	012
2.8		2.9	0.174	-	0	-	6	-10	140	FKM	390495 ₁	131.4BV	KT10 12 DC	-	10	22.0	012
2.8		2.9	0.174	-	0	-	6	-10	140	FKM	390505 ₁	131.4BV	KT10 24 DC	-	10	22.0	012

Notes:

1. La référence "N° de commande" désigne valve + bobine à la tension indiquée dans la colonne "type de bobine"
2. Selon DIN-EN-ISO 23553-1 (2009-10) pour brûleur à fuel



Dans cette page	Raccord	Orifice (mm)	Kv (l/min)	Pression Diff. Max. (bar)	Temp. Fluide (°C)	Temp. Amb. (°C)
de	1/8"	1.7	1.4	6	-30	-10
à	1/8"	2.8	3.2	30	140	50



Schéma 015



Schéma 027

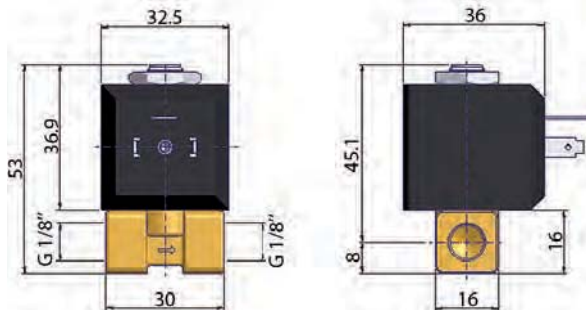

Schéma 012

2/2

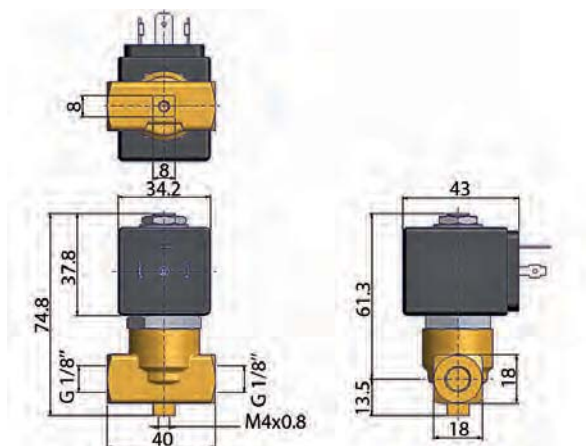
ELECTROVANNES POUR BRÛLEUR A FUEL COMMANDE DIRECTE

LAITON
RACCORD TUYAU

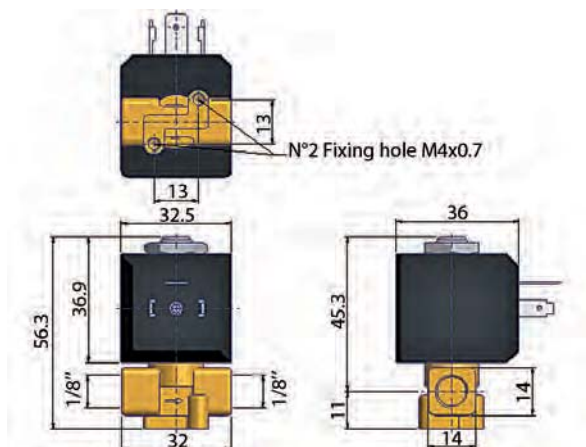
FERMÉE HORS TENSION

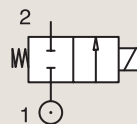

Raccord BSP	Orifice Ø mm	Facteur d'Écoulement			Pression Différentielle			Temp. Fluide		Joint	Electrovannes PARKER			Puissance		Groupe Électrique	N° Schéma	
		Kv l/min	KV m³/h	Qn m³/h	Min bar	Max AC bar	DC bar	Min °C	Max °C		N° Commande Valve	Type de Valve	Type de Bobine	AC W	DC W			
1/8"	3	4	0.24	-	0	30	-	-30	140	Ruby	362510J ₂	PM140.4AR	ZH14	14	-	20.2	025	
	4	5.3	0.318	-	0	2	-	-10	90	NBR	390874 ₁	131.4CG	KT09 115/50	9	-	22.0	013	
	4	5.3	0.318	-	0	2	-	-10	90	NBR	390813 ₁	131.4CG	KT09 115/60	9	-	22.0	013	
	4	5.3	0.318	-	0	2	-	-10	90	NBR	390878 ₁	131.4CG	KT09 230/50	9	-	22.0	013	
	4	5.3	0.318	-	0	2	-	-10	90	NBR	390805 ₁	131.4CG	KT09 24/50	9	-	22.0	013	
	4	5.3	0.318	-	0	2	-	-10	90	NBR	390875 ₁	131.4CG	KT09 240/50	9	-	22.0	013	
	4	5.3	0.318	-	0	-	1	-10	90	NBR	390803 ₁	131.4CG	KT10 12DC	-	10	22.0	013	
	4	5.3	0.318	-	0	-	1	-10	90	NBR	390802 ₁	131.4CG	KT10 24 DC	-	10	22.0	013	
1/4"	2.5	3.2	0.192	-	0	30	-	-30	140	Ruby	362518J ₂	PM140CR	ZB09	9	-	20.1/20.2	026	
	2.5	3.2	0.192	-	0	-	17	-30	140	Ruby	362518J ₁	PM140CR	ZB12	-	12	20.1/20.2	026	
	2.5	3.2	0.192	-	0	30	-	-30	140	Ruby	362518J ₁	PM140CR	ZH14	14	-	20.1/20.2	026	
	2.5	3.2	0.192	-	0	-	17	-30	140	Ruby	362518J ₁	PM140CR	ZH16	-	16	20.1/20.2	026	
	2.8	2.9	0.174	-	0	8	-	-10	140	FKM	390560 ₁	131.4FV	KT09 115/50	9	-	22.0	014	
	2.8	2.9	0.174	-	0	8	-	-10	140	FKM	390560 ₁	131.4FV	KT09 115/60	9	-	22.0	014	
	2.8	2.9	0.174	-	0	8	-	-10	140	FKM	390626 ₁	131.4FV	KT09 208-230/60	9	-	22.0	014	
	2.8	2.9	0.174	-	0	8	-	-10	140	FKM	390580 ₁	131.4FV	KT09 230/50	9	-	22.0	014	
	2.8	2.9	0.174	-	0	8	-	-10	140	FKM	390525 ₁	131.4FV	KT09 24/50	9	-	22.0	014	
	2.8	2.9	0.174	-	0	-	6	-10	140	FKM	390605 ₁	131.4FV	KT10 12 DC	-	10	22.0	014	
	2.8	2.9	0.174	-	0	-	6	-10	140	FKM	390625 ₁	131.4FV	KT10 24 DC	-	10	22.0	014	
	1/4"	3	4	0.24	-	0	30	-	-30	140	Ruby	362530J ₂	PM140.4DR	ZH14	14	-	20.0/20.1/20.2	026
		3	4	0.24	-	0	30	-	-30	140	Ruby	362524J	PM140DR	ZB09	9	-	20.1/20.2	026
		3	4	0.24	-	0	-	12	-30	140	Ruby	362524J	PM140DR	ZB12	-	12	20.1/20.2	026
		3	4	0.24	-	0	30	-	-30	140	Ruby	362524J	PM140DR	ZH14	14	-	20.1/20.2	026
		3	4	0.24	-	0	-	12	-30	140	Ruby	362524J	PM140DR	ZH16	-	16	20.1/20.2	026
		4	5.3	0.318	-	0	2	-	-10	90	NBR	390915 ₁	131.4GG	KT09 115/50	9	-	22.0	013
		4	5.3	0.318	-	0	2	-	-10	90	NBR	390945 ₁	131.4GG	KT09 230/50	9	-	22.0	013
		4	5.3	0.318	-	0	2	-	-10	90	NBR	390895 ₁	131.4GG	KT09 24/50	9	-	22.0	013
		4	5.3	0.318	-	0	2	-	-10	90	NBR	390975 ₁	131.4GG	KT09 240/50	9	-	22.0	013
4		5.3	0.318	-	0	-	1	-10	90	NBR	390995 ₁	131.4GG	KT10 12 DC	-	10	22.0	013	
4		5.3	0.318	-	0	-	1	-10	90	NBR	390997 ₁	131.4GG	KT10 24 DC	-	10	22.0	013	
4		5.3	0.318	-	0	2	-	-10	140	FKM	390668 ₁	131.4GV	KT09 115/50	9	-	22.0	014	
4	5.3	0.318	-	0	2	-	-10	140	FKM	390700 ₁	131.4GV	KT09 115/60	9	-	22.0	014		
4	5.3	0.318	-	1	2	-	-10	140	FKM	390725 ₁	131.4GV	KT09 208-230/60	9	-	22.0	014		

Notes:

1. La référence "N° de commande" désigne valve + bobine à la tension indiquée dans la colonne "type de bobine"
2. Selon DIN-EN-ISO 23553-1 (2009-10) pour brûleur à fuel



Dans cette page	Raccord	Orifice (mm)	Kv (l/min)	Pression Diff. Max. (bar)	Temp. Fluide (°C)	Temp. Amb. (°C)
de	1/8"	2.5	2.9	1	-30	-10
à	1/4"	4	5.3	30	140	50



Schéma 025



Schéma 013

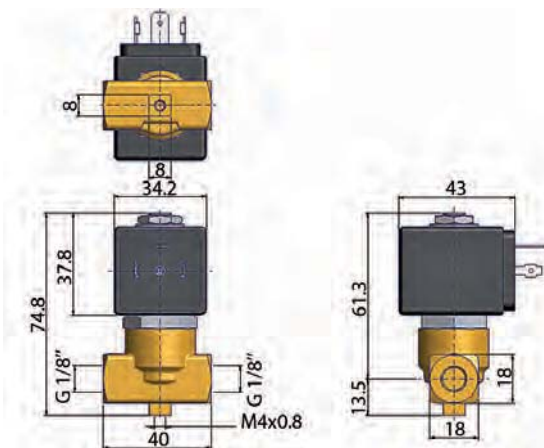

Schéma 026

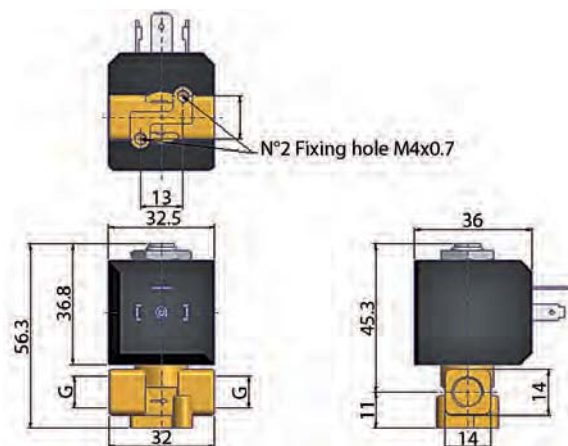

Schéma 014

2/2

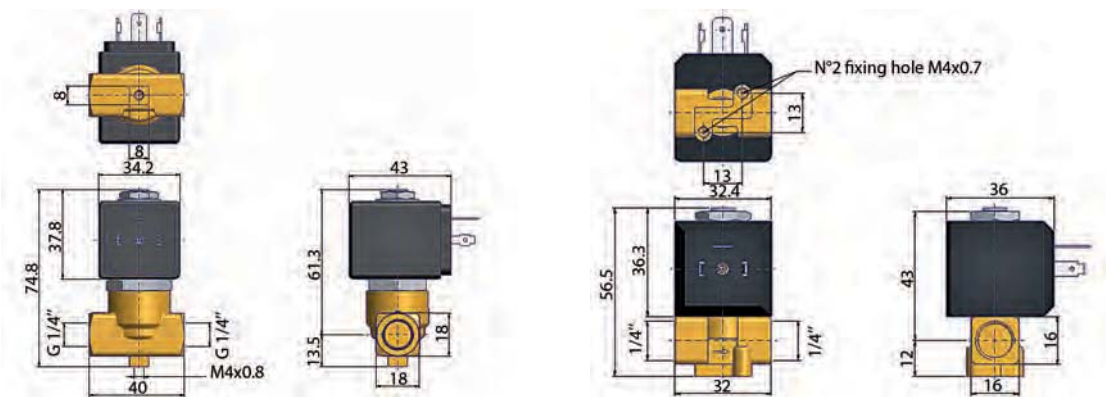
ELECTROVANNES POUR BRÛLEUR A FUEL COMMANDE DIRECTE

LAITON
RACCORD TUYAU

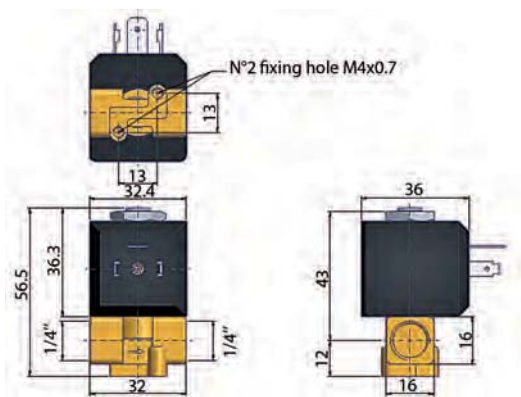
FERMÉE HORS TENSION

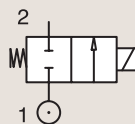

Raccord	Orifice Ø	Facteur d'Écoulement			Pression Différentielle			Temp. Fluide		Joint	Electrovannes PARKER			Puissance		Groupe Electrique	N° Schéma
		Kv l/min	KV m³/h	Qn m³/h	Min bar	Max bar	DC bar	Min °C	Max °C		N° Commande Valve	Type de Valve	Type de Bobine	AC W	DC W		
1/4"	4	5.3	0.318	-	0	2	-	-10	140	FKM	390705 ₁	131.4GV	KT09 230/50	9	-	22.0	014
	4	5.3	0.318	-	0	2	-	-10	140	FKM	390650 ₁	131.4GV	KT09 24/50	9	-	22.0	014
	4	5.3	0.318	-	0	2	-	-10	140	FKM	390718 ₁	131.4GV	KT09 240/50	9	-	22.0	014
	4	5.3	0.318	-	0	-	1	-10	140	FKM	390720 ₁	131.4GV	KT10 12 DC	-	10	22.0	014
	4	5.3	0.318	-	0	-	1	-10	140	FKM	390721 ₁	131.4GV	KT10 24 DC	-	10	22.0	014
3/8"	5	10	0.612	-	0	5	-	-10	140	FKM	364010	PM153BV	ZB14	14	-	20.2/22.0	037
	5	10	0.612	-	0	-	1.5	-10	140	FKM	364010	PM153BV	ZB16	-	16	20.2/22.0	037
1/2"	5	10	0.612	-	0	5	-	-10	140	FKM	364035	PM153GV	ZB14	14	-	20.2/22.0	037
	5	10	0.612	-	0	-	1.5	-10	140	FKM	364035	PM153GV	ZB16	-	16	20.2/22.0	037

Notes:

1. Le N° de Commande pour électrovanne comprend valve et bobine à la tension indiquée dans la colonne type de bobine



Dans cette page	Raccord	Orifice (mm)	Kv (l/min)	Pression Diff. Max. (bar)	Temp. Fluide (°C)	Temp. Amb. (°C)
de	1/4"	4	5.3	1	-10	-10
à	1/2"	5	10	5	140	50



Schéma 014



Schéma 037

2/2

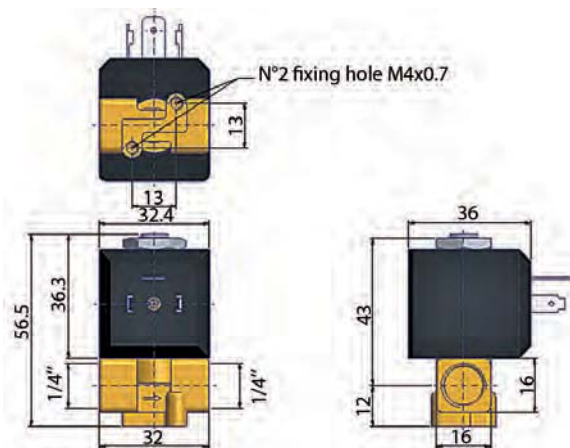
ELECTROVANNES POUR BRÛLEUR A FUEL COMMANDE DIRECTE

LAITON
RACCORD TUYAU

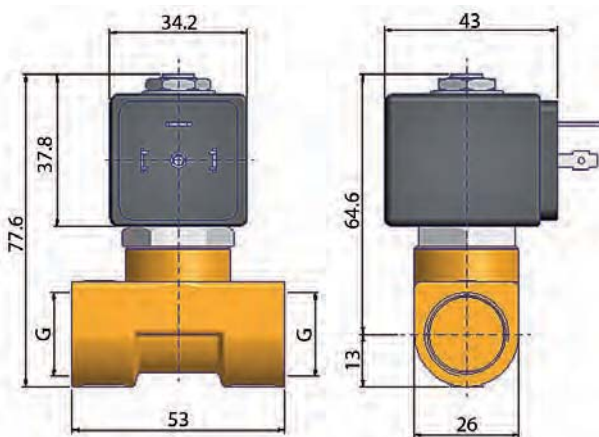
FERMÉE HORS TENSION

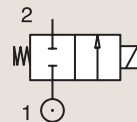

Raccord	Orifice Ø	Facteur d'Écoulement			Pression Différentielle			Temp. Fluide		Joint	Electrovannes PARKER LUCIFER®			Puissance		Groupe Electrique	N° Schéma
		Kv l/min	KV m³/h	Qn l/min	Min bar	Max AC bar	Max DC bar	Min °C	Max °C		Ref. Valve	Ref. Boîtier	Ref. Bobine	AC W	DC W		
1/8"	3	4	0.24	-	0	30	-	-30	160	Ruby	121K2423 ₂	8520.23	483824	19	-	14.1	3292
		4.5	0.27	-	0	30	-	-30	160	Ruby	121K6423 ₂	8520.23	483824	19	-	14.1	3292
1/4"	3	6.5	0.39	-	0	30	-	0	160	Ruby	121K6220 ₂	8520.23	483541	20	-	14.1	3510
		4	0.24	-	0	30	-	0	160	Ruby	121K6220 ₂	8520.23	483541	20	-	14.1	3510
3/8"	6	12	0.72	-	0	5	-	0	120	Ruby	121K3321	2995	492425	14	14	14.1	3551
		11	1.32	-	0	30	-	0	160	FKM	121G2320 ₁₂	8520.23	483541	20	-	14.1	3646
1/2"	14	25	1.5	-	0	30	-	0	160	FKM	121G2520 ₁₂	8520.23	483541	20	-	14.1	3646
		14	1.5	-	0	30	-	0	160	FKM	121G2523 ₁₂	8520.23	483824	19	-	14.1	3646

Notes:

- 1.Pression statique Max = 30 bar; Pression différentielle Max = 0.2 bar
- 2.Selon DIN-EN-ISO 23553-1 (2009-10) pour brûleur à fuel

Valve	A
121823	6 3/8"
121825	6 1/2"



Schéma 3646



Dans cette page	Raccord	Orifice (mm)	Kv (l/min)	Pression Diff. Max. (bar)	Temp. Fluide (°C)	Temp. Amb. (°C)
de	1/8"	3	4	5	-30	0
à	1/2"	14	25	30	160	60

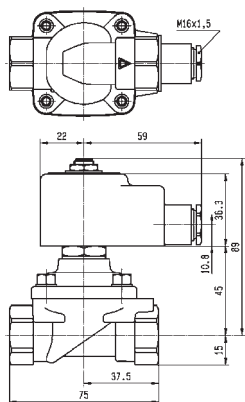
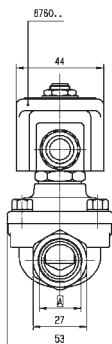
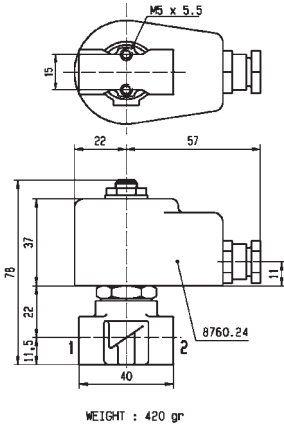

A	G 1/8"
A	G 1/4"



Schéma 3292



OPTION
Manual override
121...131K...50

A	G 1/8"	G 1/4"
A	1/8"-27 NPT	1/4"-18 NPT

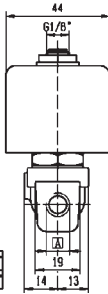
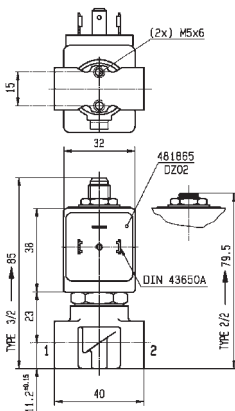

Schéma 3510



WEIGHT : 215 gr

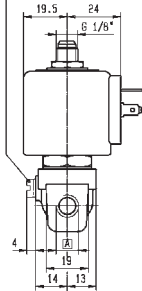
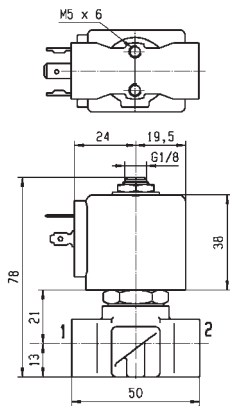

Schéma 3551

2/2

ELECTROVANNES POUR BRÛLEUR A FUEL
COMMANDE DIRECTE

LAITON

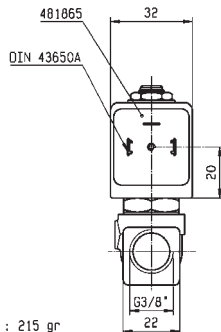
RACCORD TUYAU

OUVERTE HORS TENSION

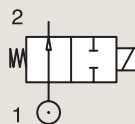

Raccord BSP	Orifice Ø mm	Facteur d'Écoulement			Pression Différentielle			Temp. Fluide		Joint	Electrovannes PARKER			Puissance		Groupe Electrique	N° Schéma
		Kv l/min	KV m³/h	Qn m³/h	Min bar	Max DC bar	Min °C	Max °C	N° Commande Valve		Type de Valve	Type de Bobine	AC W	DC W			
1/8"	3	4	0.24	-	0	30	-	-30	160	Ruby	360451J	PM120.4IR	ZB14	14	-	20.2	001
	3	4	0.24	-	0	30	-	-30	160	Ruby	360451J ₁	PM120.4IR	ZH14	14	-	20.2	001
1/4"	3	4	0.24	-	0	30	-	-30	160	Ruby	360452J	PM120.4AR	ZB14	14	-	20.2	001
	3	4	0.24	-	0	30	-	-30	160	Ruby	360452J ₁	PM120.4AR	ZH14	14	-	20.2	001

Notes:

1. Selon DIN-EN-ISO 23553-1 (2009-10) pour brûleur à fuel



Dans cette page	Raccord	Orifice (mm)	Kv (l/min)	Pression Diff. Max. (bar)	Temp. Fluide (°C)	Temp. Amb. (°C)
de	1/8"	3	4	30	-30	-10
à	1/4"	3	4	30	160	50



Schéma 001

2/2

ELECTROVANNES POUR BRÛLEUR A FUEL COMMANDE DIRECTE

LAITON

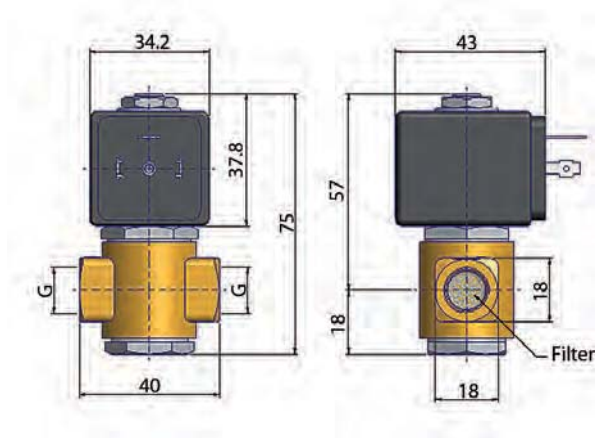
RACCORD TUYAU

OUVERTE HORS TENSION

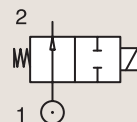

Raccord	Orifice Ø	Facteur d'Écoulement			Pression Différentielle			Temp. Fluide		Joint	Electrovannes PARKER LUCIFER®			Puissance		Groupe Electrique	N° Schéma
		Kv l/min	KV m³/h	Qn l/min	Min bar	Max AC bar	Max DC bar	Min °C	Max °C		Ref. Valve	Ref. Boîtier	Ref. Bobine	AC W	DC W		
1/8"	2.5	3.5	0.21	-	0	30	-	-30	160	Ruby	122K9321	8520.23	483824	19	-	14.1	6766
1/4"	2.5	3.5	0.21	-	0	30	-	-30	160	Ruby	122K8321	8520.23	483824	19	-	14.1	6766

Notes:

1.Selon DIN-EN-ISO 23553-1 (2009-10) pour brûleur à fuel

LAITON

MONTAGE SUR EMBASE

FERMÉE HORS TENSION

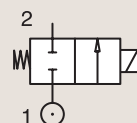

Raccord	Orifice Ø	Facteur d'Écoulement			Pression Différentielle			Temp. Fluide		Joint	Electrovannes PARKER LUCIFER®			Puissance		Groupe Electrique	N° Schéma
		Kv l/min	KV m³/h	Qn l/min	Min bar	Max AC bar	Max DC bar	Min °C	Max °C		Ref. Valve	Ref. Boîtier	Ref. Bobine	AC W	DC W		
SB	14	25	1.5	-	0	30	-	0	160	FKM	121F2523	8520.23	483824	19	-	14.1	7638

Notes:

1.Selon DIN-EN-ISO 23553-1 (2009-10) pour brûleur à fuel



Dans cette page	Raccord	Orifice (mm)	Kv (l/min)	Pression Diff. Max. (bar)	Temp. Fluide (°C)	Temp. Amb. (°C)
de	1/8"	2.5	3.5	30	-30	0
à	14 mm	14	25	30	160	60

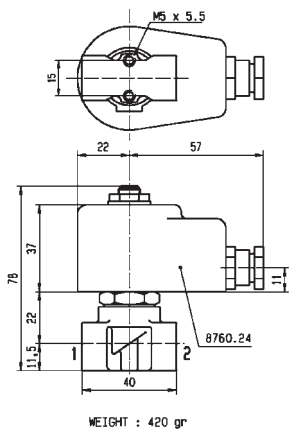

A	G 1/8"
	G 1/4"



Schéma 6766



Schéma 7638

2/2

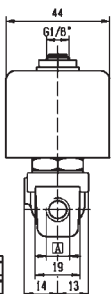
ELECTROVANNES POUR BRÛLEUR A FUEL ATTRACTION FORCÉE

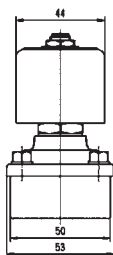
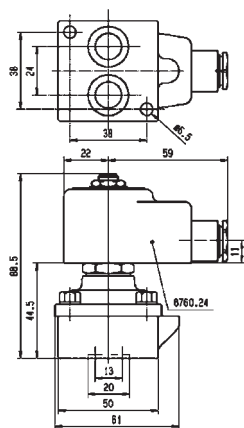

Systèmes de Chauffage

LAITON
RACCORD TUYAU

FERMÉE HORS TENSION

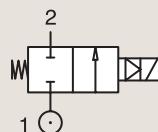

Raccord	Orifice Ø	Facteur d'Écoulement			Pression Différentielle			Temp. Fluide		Joint	Electrovannes PARKER LUCIFER®			Puissance		Groupe Electrique	N° Schéma
		Kv l/min	KV m³/h	Qn l/min	Min bar	Max AC bar	DC bar	Min °C	Max °C		Ref. Valve	Ref. Boîtier	Ref. Bobine	AC W	DC W		
1/2"	15	50	3	0	0	5	-	0	140	FKM	221G2523 ₁	8520.25	483824	19	-	14.1	8298

Notes:

1. Selon DIN-EN-ISO 23553-1 (2009-10) pour brûleur à fuel



Dans cette page	Raccord	Orifice (mm)	Kv (l/min)	Pression Diff. Max. (bar)	Temp. Fluide (°C)	Temp. Amb. (°C)
de	1/2"	15	50	5	0	0
à	1/2"	15	50	5	140	60



Schéma 8298

2/2

ELECTROVANNES POUR BRÛLEUR A FUEL SERVO-COMMANDE

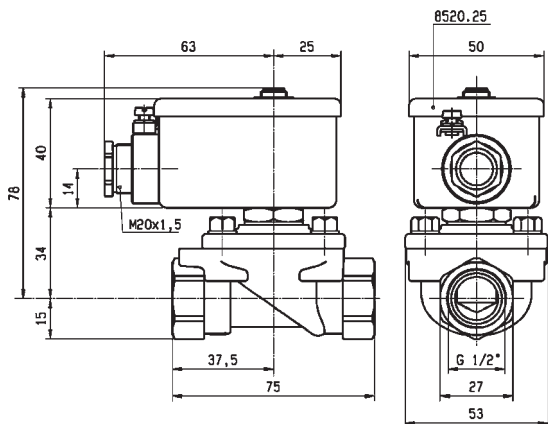

Equipement Commercial



Equipement Industriel



Systèmes de Chauffage

LAITON RACCORD TUYAU

FERMÉE HORS TENSION

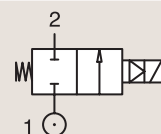

Raccord	Orifice Ø	Facteur d'écoulement			Pression Différentielle			Temp. Fluide		Joint	Electrovannes PARKER LUCIFER®			Puissance		Groupe Electrique	N° Schéma
					Min	Max		Min	Max		Ref. Valve	Ref. Boîtier	Ref. Bobine	AC W	DC W		
BSP	mm	Kv l/min	KV m³/h	Qn l/min	bar	AC bar	DC bar	°C	°C								
1/4"	8	36	2.16	-	0.3	40	25	-10	100	FKM	E321H21 ¹²³	2995	481865	8	9	2.0	3523
	8	36	2.16	-	0.3	40	30	-10	120	FKM	E321H21 ¹²³	4270	481000	8	8	2.0	3523
	8	36	2.16	-	0.3	40	40	-10	140	FKM	E321H21 ¹²³	4270	486265	14	14	2.0	3523
3/8"	11	40	2.4	-	0.3	30	-	0	160	Ruby	321H2322 ³⁴	8520.23	483541	20	-	14.1	3633
	11	50	3	-	0.3	40	25	-10	100	FKM	E321H23 ¹²³	2995	481865	8	9	2.0	3521
	11	50	3	-	0.3	40	30	-10	120	FKM	E321H23 ¹²³	4270	481000	8	8	2.0	3521
	11	50	3	-	0.3	40	40	-10	140	FKM	E321H23 ¹²³	4270	486265	14	14	2.0	3521

Notes:

1. Avec vis de réglage du temps de fermeture (4 positions)
2. Joint du clapet de pilotage en rubis synthétique
3. Pression différentielle min = 0.3 bar pour ouverture et 0 bar pour fermeture
4. Selon DIN-EN-ISO 23553-1 (2009-10) pour brûleur à fuel



Dans cette page	Raccord	Orifice (mm)	Kv (l/min)	Pression Diff. Max. (bar)	Temp. Fluide (°C)	Temp. Amb. (°C)
de	1/4"	8	36	25	-10	-10
à	3/8"	11	50	40	160	50



Schéma 3523



Schéma 3633

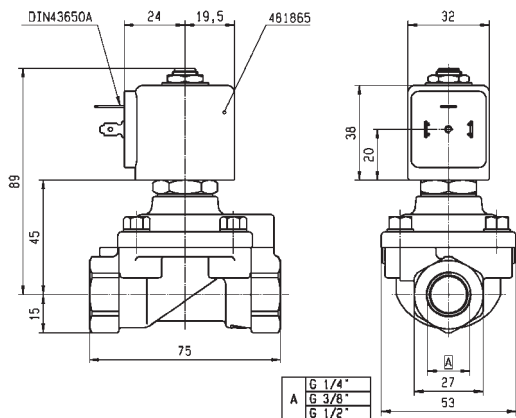

Schéma 3521

2/2

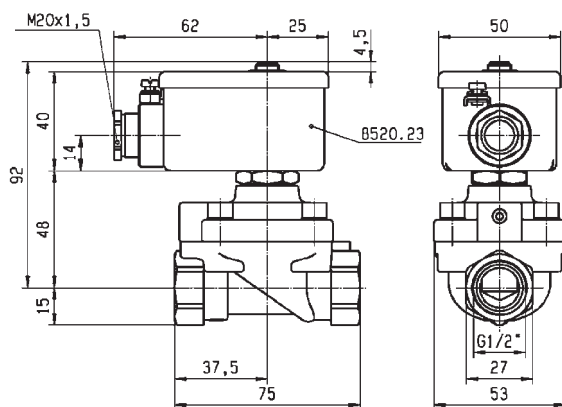
ELECTROVANNES POUR BRÛLEUR A FUEL SERVO-COMMANDE

LAITON

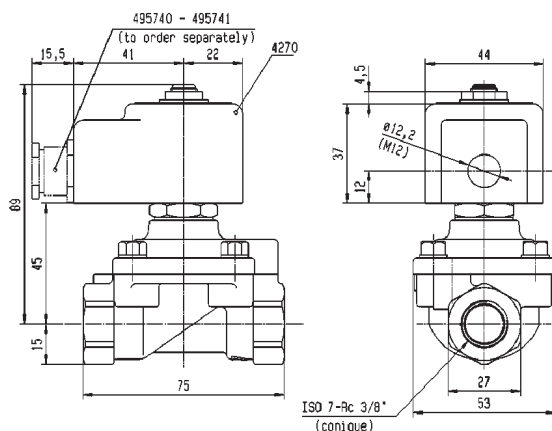
RACCORD TUYAU

FERMÉE HORS TENSION

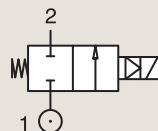

Raccord	Orifice Ø	Facteur d'Écoulement			Pression Différentielle			Temp. Fluide		Joint	Electrovannes PARKER LUCIFER®			Puissance		Groupe Electrique	N° Schéma
					Min bar	Max AC bar DC bar		Min °C	Max °C		Ref. Valve	Ref. Boîtier	Ref. Bobine	AC W	DC W		
1/2"	15	60	3.6	-	0.3	30	-	0	160	Ruby	321H2522 ₄	8520.23	483541	20	-	14.1	3633
	15	60	3.6	-	0.3	30	-	0	160	Ruby	321H2523 ₄	8520.23	483824	19	-	14.1	3633
	15	60	3.6	-	0.3	40	25	-10	100	FKM	E321H25 ₁₂₃	2995	481865	8	9	2.0/14.2	3522
	15	60	3.6	-	0.3	40	30	-10	120	FKM	E321H25 ₁₂₃	-	483371	8	8	2.0/14.2	3522
	15	60	3.6	-	0.3	40	40	-10	140	FKM	E321H25 ₁₂₃	4270	486265	14	14	2.0/14.2	3522

Notes:

1. Avec vis de réglage du temps de fermeture. (4 positions)
2. Joint du clapet de pilotage en rubis synthétique
3. Pression différentielle min = 0.3 bar pour ouverture et 0 bar pour fermeture
4. Selon DIN-EN-ISO 23553-1 (2009-10) pour brûleur à fuel

LAITON

MONTAGE SUR EMBASE

FERMÉE HORS TENSION

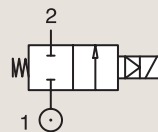

Raccord	Orifice Ø	Facteur d'Écoulement			Pression Différentielle			Temp. Fluide		Joint	Electrovannes PARKER LUCIFER®			Puissance		Groupe Electrique	N° Schéma
					Min bar	Max AC bar DC bar		Min °C	Max °C		Ref. Valve	Ref. Boîtier	Ref. Bobine	AC W	DC W		
SB	14	45	2.7	-	0	30	-	0	160	FKM	321F2523 ₁₂	8520.23	483824	19	-	14.1	7639

Notes:

1. Pression différentielle min = 0.3 bar pour ouverture et 0 bar pour fermeture
2. Selon DIN-EN-ISO 23553-1 (2009-10) pour brûleur à fuel



Dans cette page	Raccord	Orifice (mm)	Kv (l/min)	Pression Diff. Max. (bar)	Temp. Fluide (°C)	Temp. Amb. (°C)
de	1/2"	14	45	25	-10	-10
à	SB	15	60	40	160	50



Schéma 3633



Schéma 3522

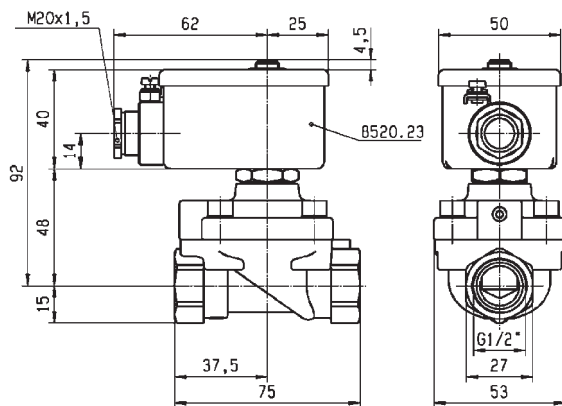

Schéma 7639

ELECTROVANNES A TEMPS DE REPONSE RAPIDE

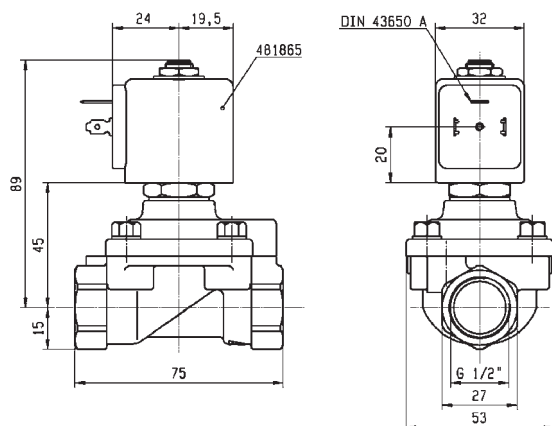

2/2

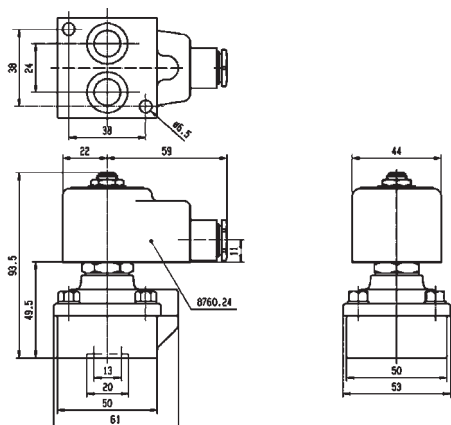
Commande	Corps de Valve	Fonction	Raccord	Orifice (mm)	Facteur d'Écoulement Kv(l/min)	Pression Différentielle (bar)	Temp. Max. Fluide (°C)	Page Valves Parker	Page Valves Parker LUCIFER®
Attraction forcée	Laiton/Raccord tuyau	Fermée hors tension	3/8"	8	0	7	40	-	198

2/2

ELECTROVANNES A TEMPS DE RÉPONSE RAPIDE ATTRACTION FORCÉE



Equipement Industriel

LAITON RACCORD TUYAU

FERMÉE HORS TENSION

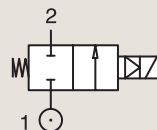

Raccord	Orifice Ø	Facteur d'Écoulement			Pression Différentielle			Temp. Fluide		Joint	Electrovannes PARKER LUCIFER®			Puissance		Groupe Electrique	N° Schéma
		Kv l/min	KV m³/h	Qn l/min	Min bar	Max AC bar	DC bar	Min °C	Max °C		Ref. Valve	Ref. Boîtier	Ref. Bobine	AC W	DC W		
BSP	8	-	-	-	0	-	7	0	40	PUR	221J3301E ₁	2995.6	483816	-	14		8020
	3/8"	8	-	-	-	0	-	7	0	40	PUR	221J3301E ₁	4270	486265	-	14	

Notes:

1. Pour plus d'information voir catalogue 8674UK

Flow rate (valve on 100%)

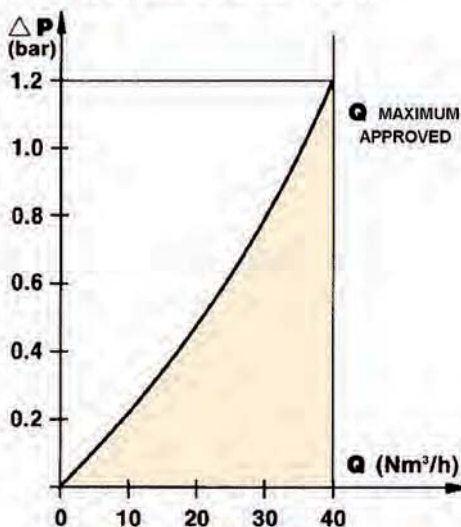



Dans cette page	Raccord	Orifice (mm)	Kv (l/min)	Pression Diff. Max. (bar)	Temp. Fluide (°C)	Temp. Amb. (°C)
de	3/8"	8	-	7	0	0
à	3/8"	8	-	7	40	50



Schéma 8020



ELECTROVANNES POUR DISTRIBUTION DE BOISSONS LIQUIPURE®

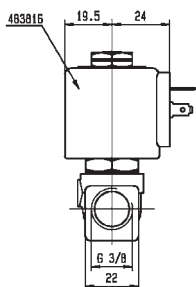
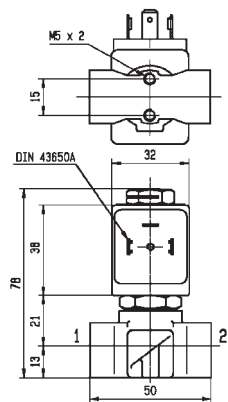

Vapeur



Eau

2/2

Commande	Corps de Valve	Fonction	Raccord	Orifice (mm)	Facteur d'Écoulement Kv(l/min)	Pression Différentielle (bar)	Temp. Max. Fluide (°C)	Page Valves Parker
Commande Directe	Inox /Montage sur embase	Fermée hors tension	SB	1.5 à 3	4.2	20	-	202

2/2

ELECTROVANNES POUR DISTRIBUTION DE BOISSONS - LIQUIPURE® COMMANDE DIRECTE



Distribution de Boissons



Médical / Instrumentation

INOX

MONTAGE SUR EMBASE

FERMÉE HORS TENSION

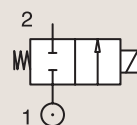

Raccord	Orifice Ø mm	Facteur d'Écoulement			Pression Différentielle			Temp. Fluide		Joint	Electrovannes PARKER			Puissance		Groupe Electrique	N° Schéma	
					Min bar	Max		Min °C	Max °C		Ref. Valve	Ref. Boîtier	Ref. Bobine	AC W	DC W			
						AC bar	DC bar											
SB	1.5	1.3	0.08	-	0	20	20	-10	140	Ruby	2019F1GRG7	-	D4	13	16	24.0	071	
	1.5	1.3	0.08	-	0	20	20	-10	140	Ruby	2019F1GRG7	-	D5	8	9	24.0	071	
	1.5	1.3	0.08	-	0	20	20	-10	140	Ruby	2019F1GRG7	-	LA	9	9	24.0	071	
	1.5	1.3	0.08	-	0	20	20	-10	140	Ruby	2019F1GRG7	-	LB-LC	13	16	24.0	071	
	1.5	1.3	0.08	-	0	20	-	-10	140	Ruby	2019F1GRG7	-	XS03	9	-	24.0	071	
	1.5	1.3	0.08	-	0	20	20	-10	140	FDA FKM	2019F1GVG7	-	D4	13	16	24.0	071	
	1.5	1.3	0.08	-	0	20	20	-10	140	FDA FKM	2019F1GVG7	-	D5	8	9	24.0	071	
	1.5	1.3	0.08	-	0	20	20	-10	140	FDA FKM	2019F1GVG7	-	LA	9	9	24.0	071	
	1.5	1.3	0.08	-	0	20	20	-10	140	FDA FKM	2019F1GVG7	-	LB-LC	13	16	24.0	071	
	1.5	1.3	0.08	-	0	20	-	-10	140	FDA FKM	2019F1GVG7	-	XS03	9	-	24.0	071	
	2	2.3	0.14	-	0	15	15	15	-10	140	Ruby	2019F1JRG7	-	D4	13	16	24.0	071
	2	2.3	0.14	-	0	15	15	15	-10	140	Ruby	2019F1JRG7	-	D5	8	9	24.0	071
	2	2.3	0.14	-	0	15	15	15	-10	140	Ruby	2019F1JRG7	-	LA	9	9	24.0	071
	2	2.3	0.14	-	0	15	15	15	-10	140	Ruby	2019F1JRG7	-	LB-LC	13	16	24.0	071
	2	2.3	0.14	-	0	15	-	-10	140	Ruby	2019F1JRG7	-	XS03	9	-	24.0	071	
	2	2.3	0.14	-	0	15	15	15	-10	140	FDA FKM	2019F1JVG7	-	D4	13	16	24.0	071
	2	2.3	0.14	-	0	15	15	15	-10	140	FDA FKM	2019F1JVG7	-	D5	8	9	24.0	071
	2	2.3	0.14	-	0	15	15	15	-10	140	FDA FKM	2019F1JVG7	-	LA	9	9	24.0	071
	2	2.3	0.14	-	0	15	15	15	-10	140	FDA FKM	2019F1JVG7	-	LB-LC	13	16	24.0	071
	2	2.3	0.14	-	0	15	-	-10	140	FDA FKM	2019F1JVG7	-	XS03	9	-	24.0	071	
2.5	3.2	0.19	-	0	10	10	10	-10	140	Ruby	2019F1LRG7	-	D4	13	16	24.0	071	
2.5	3.2	0.19	-	0	10	10	10	-10	140	Ruby	2019F1LRG7	-	D5	8	9	24.0	071	
2.5	3.2	0.19	-	0	10	10	10	-10	140	Ruby	2019F1LRG7	-	LA	9	9	24.0	071	
2.5	3.2	0.19	-	0	10	10	10	-10	140	Ruby	2019F1LRG7	-	LB-LC	13	16	24.0	071	



Dans cette page	Raccord	Orifice (mm)	Kv (l/min)	Pression Diff. Max. (bar)	Temp. Fluide (°C)	Temp. Amb. (°C)
de	SB	1.5	1.3	10	-10	-10
à	SB	2.5	3.2	20	140	50



Schéma 071

2/2

ELECTROVANNES POUR DISTRIBUTION DE BOISSONS - LIQUIPURE® COMMANDE DIRECTE

INOX

MONTAGE SUR EMBASE

FERMÉE HORS TENSION

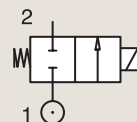

Raccord	Orifice Ø			Facteur d'Écoulement			Pression Différentielle			Temp. Fluide		Joint	Electrovannes PARKER			Puissance		Groupe Électrique	N° Schéma
													Ref. Valve	Ref. Boîtier	Ref. Bobine				
SB	2.5	3.2	0.19	-	0	10	-	-10	140	Ruby	2019F1LRG7	-	XS03	9	-	24.0	071		
	2.5	3.2	0.19	-	0	10	10	-10	140	FDA FKM	2019F1LVG7	-	D4	13	16	24.0	071		
	2.5	3.2	0.19	-	0	10	10	-10	140	FDA FKM	2019F1LVG7	-	D5	8	9	24.0	071		
	2.5	3.2	0.19	-	0	10	10	-10	140	FDA FKM	2019F1LVG7	-	LA	9	9	24.0	071		
	2.5	3.2	0.19	-	0	10	10	-10	140	FDA FKM	2019F1LVG7	-	LB-LC	13	16	24.0	071		
	2.5	3.2	0.19	-	0	10	-	-10	140	FDA FKM	2019F1LVG7	-	XS03	9	-	24.0	071		
	3	4.2	0.25	-	0	7	7	-10	140	Ruby	2019F1NRG7	-	D4	13	16	24.0	071		
	3	4.2	0.25	-	0	7	7	-10	140	Ruby	2019F1NRG7	-	D5	8	9	24.0	071		
	3	4.2	0.25	-	0	7	7	-10	140	Ruby	2019F1NRG7	-	LA	9	9	24.0	071		
	3	4.2	0.25	-	0	7	7	-10	140	Ruby	2019F1NRG7	-	LB-LC	13	16	24.0	071		
	3	4.2	0.25	-	0	7	-	-10	140	Ruby	2019F1NRG7	-	XS03	9	-	24.0	071		
	3	4.2	0.25	-	0	7	7	-10	140	FDA FKM	2019F1NVG7	-	D4	13	16	24.0	071		
	3	4.2	0.25	-	0	7	7	-10	140	FDA FKM	2019F1NVG7	-	D5	8	9	24.0	071		
	3	4.2	0.25	-	0	7	7	-10	140	FDA FKM	2019F1NVG7	-	LA	9	9	24.0	071		
	3	4.2	0.25	-	0	7	7	-10	140	FDA FKM	2019F1NVG7	-	LB-LC	13	16	24.0	071		
	3	4.2	0.25	-	0	7	-	-10	140	FDA FKM	2019F1NVG7	-	XS03	9	-	24.0	071		



Dans cette page	Raccord	Orifice (mm)	Kv (l/min)	Pression Diff. Max. (bar)	Temp. Fluide (°C)	Temp. Amb. (°C)
de	SB	2.5	3.2	7	-10	-10
à	SB	3	4.2	10	140	50



Schéma 071

ELECTROVANNES POUR AIR SEC OU LUBRIFIÉ, GAZ ET LIQUIDES NEUTRES



Huile



Eau



Air

3/2

Commande	Corps de Valve	Fonction	Raccord	Orifice (mm)	Facteur d'Écoulement Kv(l/min)	Pression Différentielle (bar)	Temp. Max. Fluide (°C)	Page Valves Parker	Page Valves Parker LUCIFER®	
Commande Directe	Laiton/Raccord tuyau	Fermée hors tension	1/8"	1.2 à 2.5	3.5	20	140	208	-	
			1/8"-1/4"	2.5	3.5	7	75	-	210	
			1/4"	1 à 4.5	7	30	140	208	-	
		Ouverte hors tension	1/4"	1.5 à 3	4.5	16	120	-	218	
		Universelle	1/8"	1.5 à 2.5	3.5	10	140	220	-	
			1/4"	0.8 à 3.5	5	30	140	220	-	
	Laiton/Montage sur embase	Fermée hors tension	Commande par impulsion	1/4"	1.5	1.5	16	100	-	224
			SB	1.3	1	20	140	226	-	
				3.5 mm	1.2 à 1.5	0.9	10	75	-	228
		Ouverte hors tension	5 mm	1 à 2.5	3.5	16	120	-	228	
			5 mm	1.5 à 2.5	2.2	15	120	-	230	
			Universelle	1/8"-1/5"	1.5	1.5	10	120	-	232
5 mm	1.5 à 2.5	3.5		10	120	-	232			
Aluminium anodisé/ Banjo	Fermée hors tension	1/8"	1.2	-	10	50	-	234		
		Inox 303 /Montage sur embase	5 mm	1.5	1.5	15	100	-	236	
			POM/Sub-base mounting	3 mm	2	2	10	50	-	238
Servo-commande	Aluminium anodisé/ Raccord tuyau	Fermée hors tension	1/4"	6.5 à 8	20	15	75	-	240	
			1/2"	14	-	15	75	-	242	
		Ouverte hors tension	1/4"	8	20	40	75	-	242	
			1/2"	14	-	15	100	-	244	
	Aluminium anodisé/ Montage sur embase/ Clapet	Fermée hors tension	1/2"	15	-	10	75	-	244	

3/2

ELECTROVANNES POUR AIR SEC OU LUBRIFIÉ, GAZ ET LIQUIDES NEUTRES COMMANDE DIRECTE



Equipement Industriel



Equipement Commercial



Process

LAITON RACCORD TUYAU

FERMÉE HORS TENSION

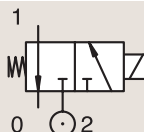

Raccord BSP	Orifice Ø		Facteur d'Écoulement			Pression Différentielle			Temp. Fluide		Joint	Electrovannes PARKER			Puissance		Groupe Electrique	N° Schéma	
	1	(2)	1	(2)	1	(2)	Min	Max	AC bar	DC bar		Min	Max	N° Commande Valve	Type de Valve	Type de Bobine			AC W
1/8"	1.2	1.6	0.7	-	0.04	-	0	8	-	-10	140	FKM	398102 ₁	N79.4IV	WB4.5 115/50-60	4.5	-	1.3	066
	1.2	1.6	0.7	-	0.04	-	0	14	-	-10	140	FKM	398104 ₁	N79.4IV	WB4.5 230/50-60	4.5	-	1.3	066
	1.2	1.6	0.7	-	0.04	-	0	14	-	-10	140	FKM	398120 ₁	N79.4IV	WB4.5 24/50-60	4.5	-	1.3	066
	1.2	1.6	0.7	-	0.04	-	0	14	-	-10	140	FKM	398100 ₁	N79.4IV	WB4.5 42/50-60	4.5	-	1.3	066
	1.2	1.6	0.7	-	0.04	-	0	14	-	-10	140	FKM	398108 ₁	N79.6IV	WB4.5 115/50-60	4.5	-	1.3	080
	1.2	1.6	0.7	-	0.04	-	0	14	-	-10	140	FKM	398110 ₁	N79.6IV	WB4.5 230/50-60	4.5	-	1.3	080
	1.2	1.6	0.7	-	0.04	-	0	14	-	-10	140	FKM	398152 ₁	N79.6IV	WB4.5 24/50-60	4.5	-	1.3	080
	1.5	1.6	1	-	0.06	-	0	8	-	-10	140	FKM	398112 ₁	N79.4AV	WB4.5 230/50-60	4.5	-	1.3	066
	1.5	1.6	1	-	0.06	-	0	8	-	-10	140	FKM	398122 ₁	N79.4AV	WB4.5 24/50-60	4.5	-	1.3	066
	1.5	1.6	1	-	0.06	-	0	8	-	-10	140	FKM	398138 ₁	N79.6AV	WB4.5 115/50-60	4.5	-	1.3	080
	1.5	1.6	1	-	0.06	-	0	8	-	-10	140	FKM	398130U ₁	N79.6AV	WB4.5 115/60	4.5	-	1.3	080
	1.5	1.6	1	-	0.06	-	0	8	-	-10	140	FKM	398114 ₁	N79.6AV	WB4.5 230/50-60	4.5	-	1.3	080
	1.5	1.6	1	-	0.06	-	0	8	-	-10	140	FKM	398142 ₁	N79.6AV	WB4.5 240/50-60	4.5	-	1.3	080
	1.5	1.5	1.2	-	0.07	-	0	20	-	-10	140	FKM	362560J	PM141AV	ZB09	9	-	20.1/20.2	029
	1/4"	2	1.6	1.5	-	0.09	-	0	5	-	-10	140	FKM	398134U ₁	N79.6BV	WB4.5 115/60	4.5	-	1.3
2		1.6	1.5	-	0.09	-	0	5	-	-10	140	FKM	398136U ₁	N79.6BV	WB4.5 208-240/60	4.5	-	1.3	080
2		1.6	1.5	-	0.09	-	0	5	-	-10	140	FKM	398132 ₁	N79.6BV	WB4.5 230/50-60	4.5	-	1.3	080
2		2.5	2	-	0.12	-	0	15	-	-10	140	FKM	362570J	PM141BV	ZB09	9	-	20.1/20.2	029
2		2.5	2	-	0.12	-	0	15	-	-10	140	FKM	362620J	PM141FV	ZB09	9	-	20.1/20.2	033
2.5		2.5	2.8	-	0.17	-	0	9	-	-10	140	FKM	362630J	PM141GV	ZB09	9	-	20.1/20.2	033

Notes:

1.La référence "N° de commande" désigne valve + bobine à la tension indiquée dans la colonne "type de bobine"



Dans cette page	Raccord	Orifice (mm)	Kv (l/min)	Pression Diff. Max. (bar)	Temp. Fluide (°C)	Temp. Amb. (°C)
de	1/8"	1.2	0.7	5	-10	-10
à	1/4"	2.5	2.8	20	140	50



Schéma 066



Schéma 080

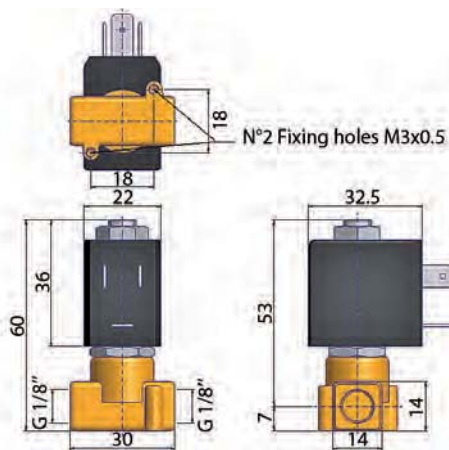

Schéma 029

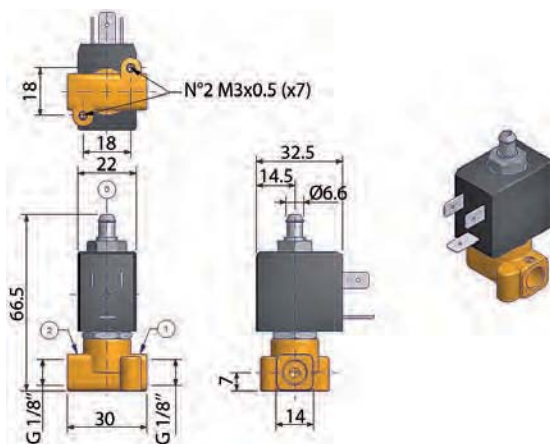

Schéma 033

3/2

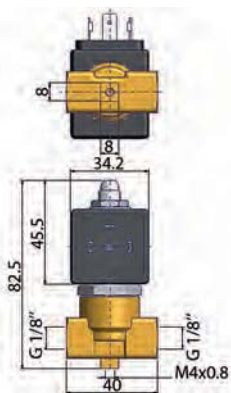
ELECTROVANNES POUR AIR SEC OU LUBRIFIÉ, GAZ ET LIQUIDES NEUTRES COMMANDE DIRECTE

LAITON
RACCORD TUYAU

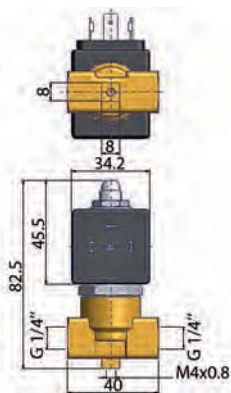
FERMÉE HORS TENSION

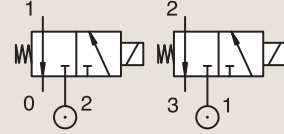

Raccord	Orifice Ø		Facteur d'Écoulement		Pression Différentielle			Temp. Fluide		Joint	Electrovannes PARKER LUCIFER®			IS	Puissance		Groupe Electrique	N° Schéma	
	1	(2)	1	(2)	Min	Max	Min	Max	Ref. Valve		Ref. Boîtier	Ref. Bobine	AC W		DC W				
BSP	mm		Kv l/min	KV m²/h	bar	AC bar	DC bar	°C	°C										
1/8"	1.2	1.5	0.7	0.9	0.042	0	10	10	-10	75	FKM	131M15	8993	488980	2	2.5	1.1	3382	
	1.5	1.5	0.9	0.9	0.054	0	7	7	-10	75	FKM	131M14	8993	488980	2	2.5	1.1	3382	
	1.5	1.5	1.5	1.5	0.09	0	15	15	-10	120	FKM	E131K14	4270	481000	8	8	2.1	3510	
	1.5	1.5	1.5	1.5	0.09	0	15	15	-10	100	FKM	E131K14	2995	481865	8	9	2.1	3510	
	2	2.5	2.5	3.5	0.15	0	10	10	-10	120	FKM	131K16	4270	481000	8	8	2.1	3510	
	2	2.5	2.5	3.5	0.15	0	10	10	-10	100	FKM	131K16	2995	481865	8	9	2.1	3510	
	2	2.5	2.5	3.5	0.15	0	10	10	-10	120	FKM	131K1650 ₁	4270	481000	8	8	2.1	3510	
	2	2.5	2.5	3.5	0.15	0	10	10	-10	100	FKM	131K1650 ₁	2995	481865	8	9	2.1	3510	
	2.5	2.5	3.5	3.5	0.21	0	7	7	-10	120	FKM	E131K13	4270	481000	8	8	2.0	3510	
	2.5	2.5	3.5	3.5	0.21	0	7	7	-10	100	FKM	E131K13	2995	481865	8	9	2.0	3510	
1/8"-1/4"	2.5	2.5	3	3	0.18	0	-	2	-20	75	PUR	131K0397	2995	482740	-	1.6	6.0/8.0	8023	
	2.5	2.5	3	3	0.18	0	2	2	-20	75	PUR	131K0397	-	495900	2.5	2	6.0/8.0	8023	
	2.5	2.5	3	3	0.18	0	-	2	-20	75	PUR	131K0397	-	495910	*	-	0.3 to 3	6.0/8.0	8023
	2.5	2.5	3.5	3.5	0.21	0	7	7	-40	75	PUR	E131K0358 ₁	4270	481000	8	8	2.1	3510	
	2.5	2.5	3.5	3.5	0.21	0	7	7	-40	75	PUR	E131K0358 ₁	2995	481865	8	9	2.1	3510	
1/4"	1	1	0.6	0.6	0.036	0	-	10	-10	55	FKM	131K0490	2995	483580.01	*	-	0.5 to 3	7.0	7058
	1	1	0.6	0.6	0.036	0	-	10	-10	75	FKM	131K0490	-	488660.01	*	-	0.3 to 3	7.0	7058
	1	1	0.6	-	0.036	-	0	-	10	75	FKM	131K0490	-	495910	*	-	0.3 to 3	7.0	7058

Notes:

1. Avec Commande manuelle



Schéma 7058



Dans cette page	Raccord	Orifice (mm)	Kv (l/min)	Pression Diff. Max. (bar)	Temp. Fluide (°C)	Temp. Amb. (°C)
de	1/8"	1	0.6	2	-40	-40
à	1/4"	2.5	3.5	15	120	50

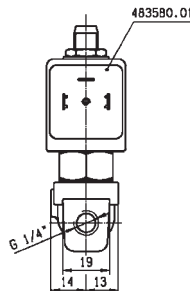
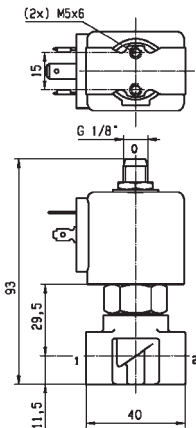

Schéma 3382



Schéma 3510

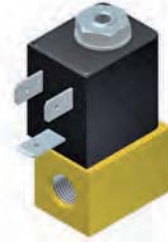
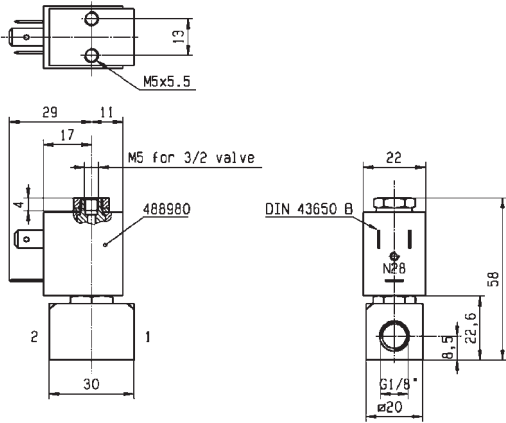

Schéma 8023

3/2

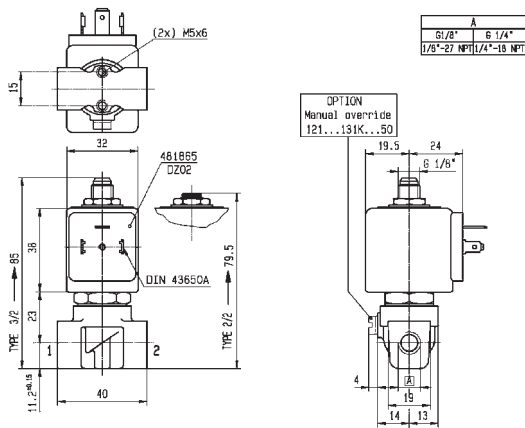
ELECTROVANNES POUR AIR SEC OU LUBRIFIÉ, GAZ ET LIQUIDES NEUTRES COMMANDE DIRECTE

LAITON

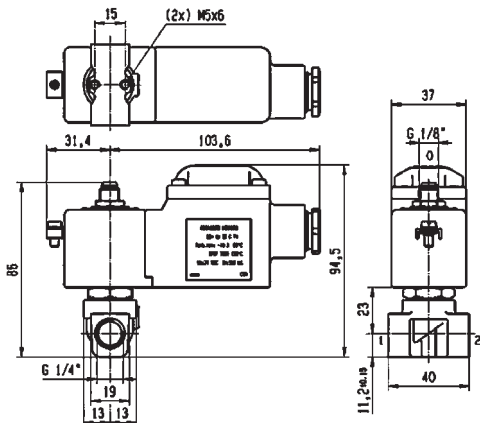
RACCORD TUYAU

FERMÉE HORS TENSION

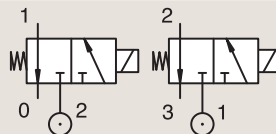

Raccord	Orifice Ø			Facteur d'Écoulement			Pression Différentielle			Temp. Fluide		Joint	Electrovannes PARKER LUCIFER®			IS	Puissance		Groupe Electrique	N° Schéma
	1	(2)		1	(2)		Min	Max		Min	Max		Ref. Valve	Ref. Boîtier	Ref. Bobine		AC W	DC W		
BSP	mm			Kv l/min			bar	AC bar	DC bar	°C	°C									
1/4"	1.2	1.5	0.8	1.5	0.048	0.09	0	30	-	-30	130	Ruby	E131K64	4270	481000	8	-	2.0	3510	
	1.2	1.5	0.8	1.5	0.048	0.09	0	30	30	-30	140	Ruby	E131K64	4270	486265	14	14	2.0	3510	
	1.2	1.5	0.8	1.5	0.048	0.09	0	30	-	-30	130	Ruby	E131K6450 ₁	4270	481000	8	-	2.0	3510	
	1.2	1.5	0.8	1.5	0.048	0.09	0	30	30	-30	140	Ruby	E131K6450 ₁	4270	486265	14	14	2.0	3510	
	1.5	1.5	1.5	1.5	0.09	0.09	0	-	7	-20	75	PUR	131K0497	2995	482740	-	1.6	6.0/8.0	8023	
	1.5	1.5	1.5	1.5	0.09	0.09	0	7	7	-20	75	PUR	131K0497	-	495900	2.5	2	6.0/8.0	8023	
	1.5	1.5	1.5	1.5	0.09	0.09	0	-	7	-20	75	PUR	131K0497	-	495910	*	-	0.3 to 3	6.0/8.0	8023
	1.5	1.5	1.5	1.5	0.09	0.09	0	-	7	-20	75	PUR	131K0497	2995	496125	-	1.6	6.0/8.0	8023	
	1.5	1.5	1.5	1.5	0.09	0.09	0	16	16	-10	120	FKM	E131K04	4270	481000	8	8	2.0	3510	
	1.5	1.5	1.5	1.5	0.09	0.09	0	16	16	-10	100	FKM	E131K04	2995	481865	8	9	2.0	3510	
	1.5	1.5	1.5	1.5	0.09	0.09	0	16	16	-10	120	FKM	E131K04	4270	486265	14	14	2.0	3510	
	1.5	1.5	1.5	1.5	0.09	0.09	0	15	15	-10	120	FKM	E131K0450 ₁	4270	481000	8	8	2.1	3510	
	1.5	1.5	1.5	1.5	0.09	0.09	0	15	15	-10	100	FKM	E131K0450 ₁	2995	481865	8	9	2.1	3510	
	2	3	2.5	4.5	0.15	0.27	0	10	10	-10	75	FKM	131T23	4270	481000	8	8	2.0	3223	
	2	3	2.5	4.5	0.15	0.27	0	10	10	-10	75	FKM	131T23	2995	481865	8	9	2.0	3223	
	2	3	2.5	4.5	0.15	0.27	0	10	10	-10	75	FKM	131T23	4270	486265	14	14	2.0	3223	
2	3	2.5	4.5	0.15	0.27	0	10	10	-10	75	FKM	131T2301 ₁	4270	481000	8	8	2.0	3223		
2	3	2.5	4.5	0.15	0.27	0	10	10	-10	75	FKM	131T2301 ₁	2995	481865	8	9	2.0	3223		
2	3	2.5	4.5	0.15	0.27	0	10	10	-10	75	FKM	131T2301 ₁	4270	486265	14	14	2.0	3223		

Notes:

1. Avec Commande manuelle



Dans cette page	Raccord	Orifice (mm)	Kv (l/min)	Pression Diff. Max. (bar)	Temp. Fluide (°C)	Temp. Amb. (°C)
de	1/4"	1.2	0.8	7	-30	-20
à	1/4"	2	2.5	30	140	50



Schéma 3510



Schéma 8023

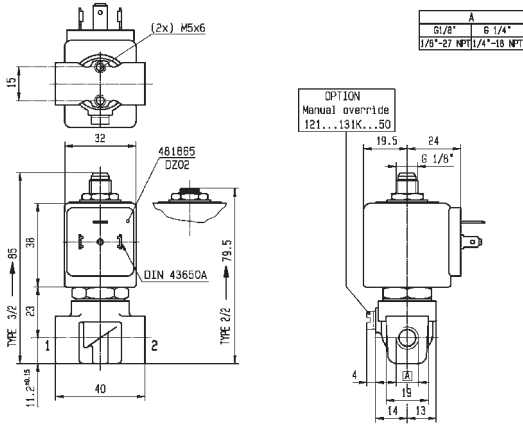

Schéma 3223

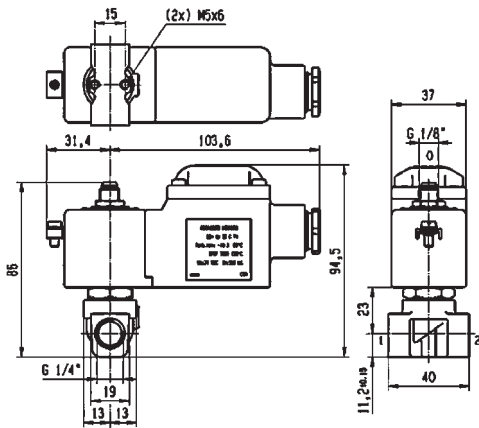

Dans cette page	Raccord	Orifice (mm)	Kv (l/min)	Pression Diff. Max. (bar)	Temp. Fluide (°C)	Temp. Amb. (°C)
de	1/4"	2	2.5	2	-20	-20
à	1/4"	2.5	3.5	10	120	50

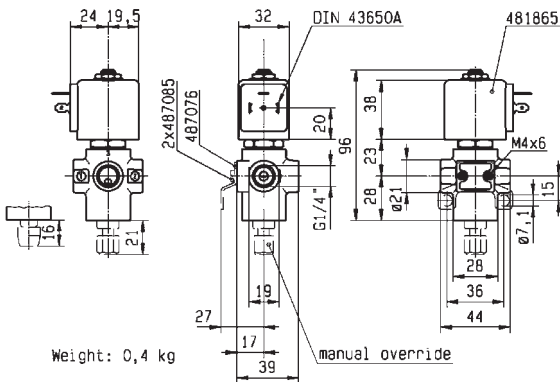

Schéma 8119



Schéma 3510

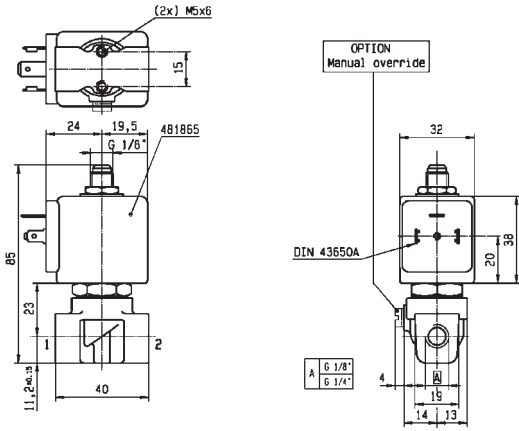

Schéma 8023

3/2

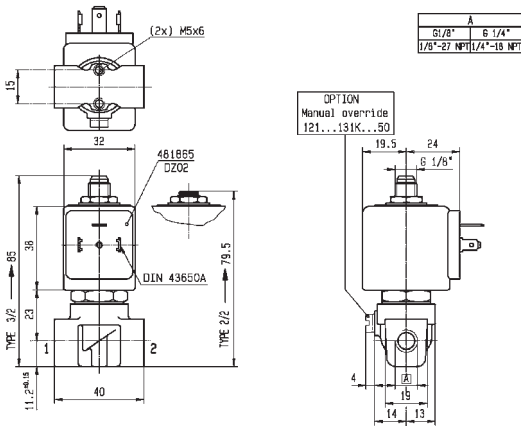
ELECTROVANNES POUR AIR SEC OU LUBRIFIÉ, GAZ ET LIQUIDES NEUTRES COMMANDE DIRECTE

LAITON

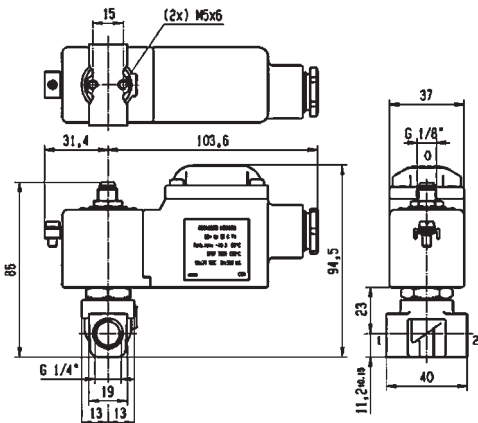
RACCORD TUYAU

FERMÉE HORS TENSION

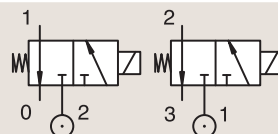

Raccord	Orifice Ø		Facteur d'Écoulement				Pression Différentielle			Temp. Fluide		Joint	Electrovannes PARKER LUCIFER®			Puissance		Groupe Electrique	N° Schéma
	1	(2)	1	(2)	1	(2)	Min	Max	Max	Min	Max		Ref. Valve	Ref. Boîtier	Ref. Bobine	AC W	DC W		
BSP	mm		Kv l/min		KV m³/h		bar	AC bar	DC bar	°C	°C								
1/4"	2.5	6	2.7	15	0.162	0.9	0.1	7	7	-10	75	FKM	E131E03	4270	481000	8	8	2.0	3525
	2.5	6	2.7	15	0.162	0.9	0.1	7	7	-10	75	FKM	E131E03	2995	481865	8	9	2.0	3525
	2.5	6	2.7	15	0.162	0.9	0.1	7	7	-10	75	FKM	E131E03	4270	486265	14	14	2.0	3525
	2.5	2.5	3.5	3.5	0.21	0.21	0	7	7	-10	100	FKM	E131K03	4270	481000	8	8	2.0	3510
	2.5	2.5	3.5	3.5	0.21	0.21	0	7	7	-10	100	FKM	E131K03	2995	481865	8	9	2.0	3510
	2.5	2.5	3.5	3.5	0.21	0.21	0	7	7	-40	75	PUR	E131K0308	4270	481000	8	8	2.1	3510
	2.5	2.5	3.5	3.5	0.21	0.21	0	7	7	-40	75	PUR	E131K0308	2995	481865	8	9	2.1	3510
	2.5	2.5	3.5	3.5	0.21	0.21	0	7	7	-10	120	FKM	E131K0350 ₁	4270	481000	8	8	2.1	3510
	2.5	2.5	3.5	3.5	0.21	0.21	0	7	7	-10	100	FKM	E131K0350 ₁	2995	481865	8	9	2.1	3510
	2.5	2.5	3.5	3.5	0.21	0.21	0	7	7	-30	130	Ruby	E131K63	4270	481000	8	8	2.0	3510
	2.5	2.5	3.5	3.5	0.21	0.21	0	7	7	-30	100	Ruby	E131K63	2995	481865	8	9	2.0	3510
	2.5	2.5	3.5	3.5	0.21	0.21	0	7	7	-30	130	Ruby	E131K6350 ₁	4270	481000	8	8	2.1	3510
	2.5	2.5	3.5	3.5	0.21	0.21	0	7	7	-30	100	Ruby	E131K6350 ₁	2995	481865	8	9	2.1	3510
	3	4	4.5	6	0.27	0.36	0	10	-	-10	75	FKM	131T22	4270	481044	14	-	2.2	3223
	3	4	4.5	6	0.27	0.36	0	10	-	-10	75	FKM	131T22	2995	492425	14	-	2.2	3223
	4.5	6	7	9	0.42	0.54	0	2	2	-10	75	FKM	131T21	4270	481000	8	8	2.0	3223
4.5	6	7	9	0.42	0.54	0	2	2	-10	75	FKM	131T21	2995	481865	8	9	2.0	3223	
4.5	6	7	9	0.42	0.54	0	2	2	-10	75	FKM	131T21	4270	486265	14	14	2.0	3223	

Notes:

1. Avec Commande manuelle

3/2

ELECTROVANNES POUR AIR SEC OU LUBRIFIÉ, GAZ ET LIQUIDES NEUTRES COMMANDE DIRECTE

LAITON

RACCORD TUYAU

OUVERTE HORS TENSION

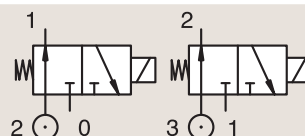

Raccord	Orifice Ø		Facteur d'Écoulement				Pression Différentielle			Temp. Fluide		Joint	Electrovannes PARKER LUCIFER®			Puissance		Groupe Electrique	N° Schéma
	1	(2)	1	(2)	1	(2)	Min	Max		Min	Max		Ref. Valve	Ref. Boîtier	Ref. Bobine	AC W	DC W		
BSP	mm		Kv		KV		bar	AC bar	DC bar	°C	°C								
1/4"	1.5	1.5	1.4	1.4	0.08	0.08	0	16	16	-10	120	FKM	132K04	4270	481000	8	8	2.1	3510
	1.5	1.5	1.4	1.4	0.08	0.08	0	16	16	-10	100	FKM	132K04	2995	481865	8	9	2.1	3510
	2	2	1.8	1.8	0.11	0.11	0	10	10	-10	120	FKM	132K06	4270	481000	8	8	2.1	3510
	2	2	1.8	1.8	0.11	0.11	0	10	10	-10	100	FKM	132K06	2995	481865	8	9	2.1	3510
	2	3	2.5	4.5	0.15	0.27	0	10	5	-10	75	FKM	132T23	4270	481000	8	8	2.0	3223
	2	3	2.5	4.5	0.15	0.27	0	10	5	-10	75	FKM	132T23	2995	481865	8	9	2.0	3223
	2	3	2.5	4.5	0.15	0.27	0	-	10	-10	75	FKM	132T23	4270	486265	-	14	2.0	3223
	2	3	2.5	4.5	0.15	0.27	0	10	5	-10	75	FKM	132T2301 ₁	4270	481000	8	8	2.0	3223
	2	3	2.5	4.5	0.15	0.27	0	10	5	-10	75	FKM	132T2301 ₁	2995	481865	8	9	2.0	3223
	2	3	2.5	4.5	0.15	0.27	0	-	10	-10	75	FKM	132T2301 ₁	4270	486265	-	14	2.0	3223
	2.5	2.5	2.2	2.2	0.13	0.13	0	7	7	-10	120	FKM	132K03	4270	481000	8	8	2.1	3510
	2.5	2.5	2.2	2.2	0.13	0.13	0	7	7	-10	100	FKM	132K03	2995	481865	8	9	2.1	3510
	3	4	4.5	6	0.27	0.36	0	10	-	-10	75	FKM	132T22	4270	481044	14	-	2.2	3223
	3	4	4.5	6	0.27	0.36	0	7	-	-10	75	FKM	132T22	2995	492425	14	-	2.2	3223

Notes:

1. Avec Commande manuelle

3/2

ELECTROVANNES POUR AIR SEC OU LUBRIFIÉ, GAZ ET LIQUIDES NEUTRES COMMANDE DIRECTE

LAITON

RACCORD TUYAU

UNIVERSELLE

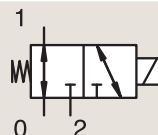

Raccord	Orifice Ø		Facteur d'Écoulement			Pression Différentielle			Temp. Fluide		Joint	Electrovannes PARKER			Puissance		Groupe Electrique	N° Schéma	
	1	(2)	1	(2)	1	(2)	Min	Max	Min	Max		N° Commande Valve	Type de Valve	Type de Bobine	AC W	DC W			
BSP	mm		Kv l/min		KV m³/h		bar	AC bar	DC bar	°C	°C								
1/8"	1.5	1.5	1.2	-	0.07	-	0	10	-	-10	140	FKM	362410J	PM139AV	ZB09	9	-	20.1/20.2	022
	1.5	1.5	1.2	-	0.07	-	0	-	10	-10	140	FKM	362410J	PM139AV	ZB12	-	12	20.1/20.2	022
1/4"	2	2	2	-	0.12	-	0	7	-	-10	140	FKM	362460J	PM139FV	ZB09	9	-	20.1/20.2	022
	2	2	2	-	0.12	-	0	-	7	-10	140	FKM	362460J	PM139FV	ZB12	-	12	20.1/20.2	022
	2.5	2.5	2.8	-	0.17	-	0	4	-	-10	140	FKM	362470J	PM139GV	ZB09	9	-	20.1/20.2	022
	2.5	2.5	2.8	-	0.17	-	0	-	4	-10	140	FKM	362470J	PM139GV	ZB12	-	12	20.1/20.2	022
	3.5	2.5	5	-	0.3	-	0	1	-	-10	140	FKM	362475J	PM139LV	ZB09	9	-	20.1/20.2	022
	3.5	2.5	5	-	0.3	-	0	-	1	-10	140	FKM	362475J	PM139LV	ZB12	-	12	20.1/20.2	022



Dans cette page	Raccord	Orifice (mm)	Kv (l/min)	Pression Diff. Max. (bar)	Temp. Fluide (°C)	Temp. Amb. (°C)
de	1/8"	1.5	1.2	1	-10	-10
à	1/4"	3.5	5	10	140	50



Schéma 022

3/2

ELECTROVANNES POUR AIR SEC OU LUBRIFIÉ, GAZ ET LIQUIDES NEUTRES COMMANDE DIRECTE

LAITON

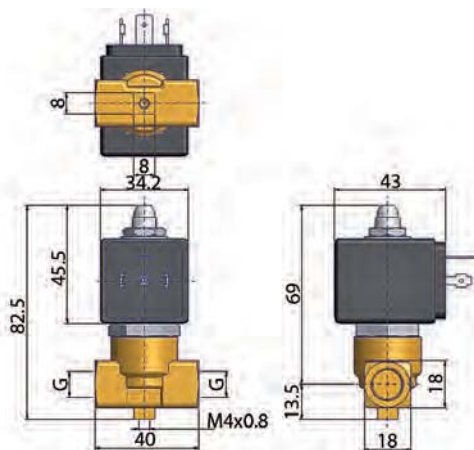
RACCORD TUYAU

UNIVERSELLE

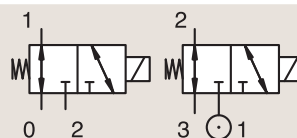

Raccord	Orifice Ø		Facteur d'Écoulement		Pression Différentielle			Temp. Fluide		Joint	Electrovannes PARKER LUCIFER®			IS	Puissance		Groupe Electrique	N° Schéma		
	1	(2)	1	(2)	1	(2)	Min	Max	Min		Max	Ref. Valve	Ref. Boîtier		Ref. Bobine	AC W			DC W	
BSP	mm		Kv l/min		KV m³/h		bar	AC bar	DC bar	°C	°C									
1/8"	1.5	1.5	1.5	1.5	0.09	0.09	0	10	10	-10	100	FKM	E133K14	2995	481865	8	9	2.1	3510	
	1.5	1.5	1.5	1.5	0.09	0.09	0	10	10	-10	120	FKM	E133K14	4270	481000	8	8	2.1	3510	
	2	2	2.5	2.5	0.15	0.15	0	7	7	-10	100	FKM	E133K16	2995	481865	8	9	2.1	3510	
	2	2	2.5	2.5	0.15	0.15	0	7	7	-10	120	FKM	E133K16	4270	481000	8	8	2.1	3510	
	2.5	2.5	3.5	3.5	0.21	0.21	0	4	4	-10	100	FKM	E133K13	2995	481865	8	9	2.1	3510	
	2.5	2.5	3.5	3.5	0.21	0.21	0	4	4	-10	120	FKM	E133K13	4270	481000	8	8	2.1	3510	
1/4"	0.8	0.8	0.3	0.3	0.0180	0.018	0	30	30	-10	100	FKM	E133K05	2995	481865	8	9	2.1	3510	
	0.8	0.8	0.3	0.3	0.0180	0.018	0	30	30	-10	120	FKM	E133K05	4270	481000	8	8	2.1	3510	
	0.8	0.8	0.3	0.3	0.0180	0.018	0	30	30	-10	120	FKM	E133K05	4270	486265	14	14	2.0	3510	
	1.5	1.5	1.5	1.5	0.09	0.09	0	-	3	-20	75	PUR	133K0497	2995	482740	-	1.6	6.0/8.0	8023	
	1.5	1.5	1.5	1.5	0.09	0.09	0	3	3	-20	75	PUR	133K0497	-	495900	2.5	2	6.0/8.0	8023	
	1.5	1.5	1.5	1.5	0.09	0.09	0	-	3	-20	75	PUR	133K0497	-	495910	*	-	0.3 to 3	6.0/8.0	8023
	1.5	1.5	1.5	1.5	0.09	0.09	0	-	3	-20	75	PUR	133K0497	2995	496125	-	1.6	6.0/8.0	8023	
	1.5	1.5	1.5	1.5	0.09	0.09	0	10	10	-10	100	FKM	E133K04	2995	481865	8	9	2.0	3510	
	1.5	1.5	1.5	1.5	0.09	0.09	0	10	10	-10	120	FKM	E133K04	4270	481000	8	8	2.0	3510	
	1.5	1.5	1.5	1.5	0.09	0.09	0	10	10	-10	120	FKM	E133K04	4270	486265	14	14	2.0	3510	
	1.5	1.5	1.5	1.5	0.09	0.09	0	10	10	-10	100	FKM	E133K0450	2995	481865	8	9	2.1	3510	
	1.5	1.5	1.5	1.5	0.09	0.09	0	10	10	-10	120	FKM	E133K0450	4270	481000	8	8	2.1	3510	
	2	2	2.5	2.5	0.15	0.15	0	7	7	-10	75	FKM	133T23	2995	481865	8	9	2.1	3223	
	2	2	2.5	2.5	0.15	0.15	0	7	7	-10	75	FKM	133T23	4270	481000	8	8	2.1	3223	
	2	2	2.5	2.5	0.15	0.15	0	7	7	-10	75	FKM	133T2301	2995	481865	8	9	2.1	3223	
	2	2	2.5	2.5	0.15	0.15	0	7	7	-10	75	FKM	133T2301	4270	481000	8	8	2.1	3223	
	2	2	2.5	2.5	0.15	0.15	0	7	7	-10	100	FKM	E133K06	2995	481865	8	9	2.0/3.0	3510	
	2	2	2.5	2.5	0.15	0.15	0	7	7	-10	120	FKM	E133K06	4270	481000	8	8	2.0/3.0	3510	
	2	2	2.5	2.5	0.15	0.15	0	7	7	-10	120	FKM	E133K06	4270	486265	14	14	2.0/3.0	3510	
	2	2	2.5	2.5	0.15	0.15	0	7	7	-10	100	FKM	E133K0650	2995	481865	8	9	2.1	3510	
	2	2	2.5	2.5	0.15	0.15	0	7	7	-10	120	FKM	E133K0650	4270	481000	8	8	2.1	3510	
	2.5	2.5	3.5	3.5	0.21	0.21	0	4	4	-10	100	FKM	E133K03	2995	481865	8	9	2.0	3510	
	2.5	2.5	3.5	3.5	0.21	0.21	0	4	4	-10	120	FKM	E133K03	4270	481000	8	8	2.0	3510	
	2.5	2.5	3.5	3.5	0.21	0.21	0	4	4	-10	120	FKM	E133K03	4270	486265	14	14	2.0	3510	
	2.5	2.5	3.5	3.5	0.21	0.21	0	4	4	-10	100	FKM	E133K0350	2995	481865	8	9	2.1	3510	
	2.5	2.5	3.5	3.5	0.21	0.21	0	4	4	-10	120	FKM	E133K0350	4270	481000	8	8	2.1	3510	
	3	3	4.5	4.5	0.27	0.27	0	2	2	-10	75	FKM	133T21	2995	481865	8	9	2.1	3223	
	3	3	4.5	4.5	0.27	0.27	0	2	2	-10	75	FKM	133T21	4270	481000	8	8	2.1	3223	

Notes:

1. Avec Commande manuelle



Dans cette page	Raccord	Orifice (mm)	Kv (l/min)	Pression Diff. Max. (bar)	Temp. Fluide (°C)	Temp. Amb. (°C)
de	1/8"	0.8	0.3	2	-20	-20
à	1/4"	3	4.5	30	120	50



Schéma 3510



Schéma 8023

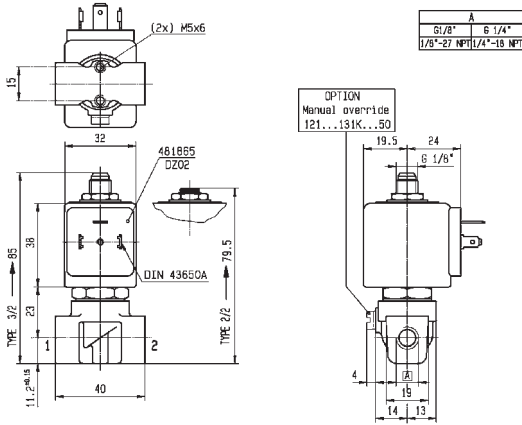

Weight: 0,4 kg

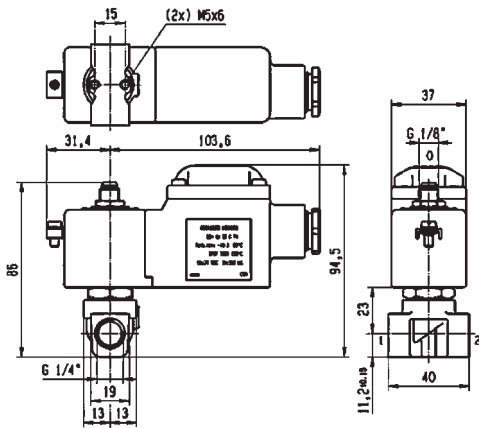
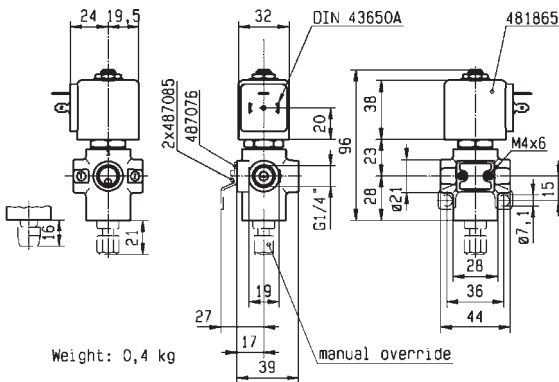

Schéma 3223

3/2

ELECTROVANNES POUR AIR SEC OU LUBRIFIÉ, GAZ ET LIQUIDES NEUTRES COMMANDE DIRECTE

LAITON

RACCORD TUYAU

UNIVERSELLE

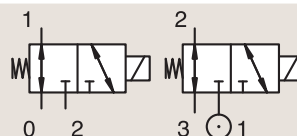

Raccord	Orifice Ø		Facteur d'Écoulement				Pression Différentielle			Temp. Fluide		Joint	Electrovannes PARKER LUCIFER®			Puissance		Groupe Electrique	N° Schéma
	1	(2)	1	(2)	1	(2)	Min	Max		Min	Max		Ref. Valve	Ref. Boîtier	Ref. Bobine	AC W	DC W		
BSP	mm		Kv l/min		KV m³/h		bar	AC bar	DC bar	°C	°C								
1/4"	3	3	4.5	4.5	0.27	0.27	0	2	2	-10	75	FKM	133T2101 ₁	2995	481865	8	9	2.1	3223
	3	3	4.5	4.5	0.27	0.27	0	2	2	-10	75	FKM	133T2101 ₁	4270	481000	8	8	2.1	3223

Notes:

1.Avec Commande manuelle

LAITON

RACCORD TUYAU

COMMANDE PAR IMPULSION

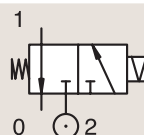

Raccord	Orifice Ø		Facteur d'Écoulement				Pression Différentielle			Temp. Fluide		Joint	Electrovannes PARKER LUCIFER®			Puissance		Groupe Electrique	N° Schéma
	1	(2)	1	(2)	1	(2)	Min	Max		Min	Max		Ref. Valve	Ref. Boîtier	Ref. Bobine	AC W	DC W		
BSP	mm		Kv l/min		KV m³/h		bar	AC bar	DC bar	°C	°C								
1/4"	1.5	1.5	1.5	1.5	0.09	0.09	0	-	16	-10	100	FKM	135K04	4269	485400	-	13	4.0	8104



Dans cette page	Raccord	Orifice (mm)	Kv (l/min)	Pression Diff. Max. (bar)	Temp. Fluide (°C)	Temp. Amb. (°C)
de	1/4"	1.5	1.5	2	-10	-10
à	1/4"	3	4.5	16	100	50

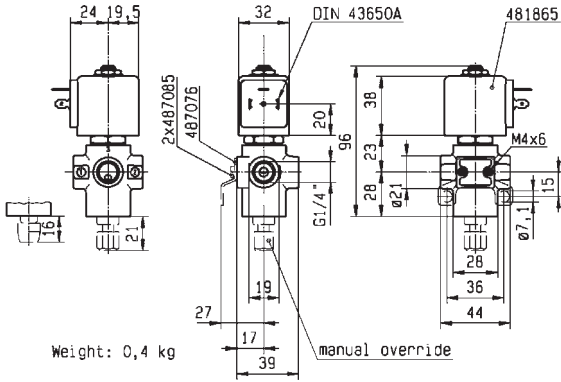

Weight: 0,4 kg



Schéma 3223



Schéma 8104

3/2

ELECTROVANNES POUR AIR SEC OU LUBRIFIÉ, GAZ ET LIQUIDES NEUTRES COMMANDE DIRECTE

LAITON

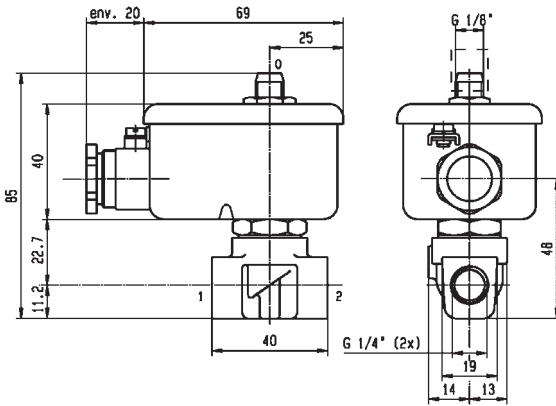
MONTAGE SUR EMBASE

FERMÉE HORS TENSION

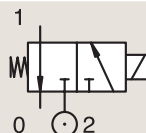

Raccord	Orifice Ø		Facteur d'Écoulement		Pression Différentielle			Temp. Fluide		Joint	Electrovannes PARKER			Puissance		Groupe Electrique	N° Schéma		
	1	(2)	1	(2)	1	(2)	Min	Max	Min		Max	N° Commande Valve	Type de Valve	Type de Bobine	AC W			DC W	
	mm		Kv l/min		KV m³/h		bar	AC bar	DC bar	°C	°C								
SB	1.3	2.5	1	-	0.06	-	0	20	10	-30	140	Ruby	360490J ₁	PM128GR	ZB09	9	-	20.1/20.2	009
	1.3	2.5	1	-	0.06	-	0	20	10	-30	140	Ruby	360480J ₁	PM128IR	YB09	9	-	20.1/20.2	010
	1.3	2.5	1	-	0.06	-	0	20	10	-30	140	Ruby	360480J ₁	PM128IR	ZB09	9	-	20.1/20.2	010
	1.3	2.5	1	-	0.06	-	0	20	10	-10	140	FKM	360506 ₁	PM128ISV	ZB09	9	-	20.1/20.2	010
	1.3	2.5	1	-	0.06	-	0	20	10	-10	140	FKM	360479J ₁	PM128IV	ZB09	9	-	20.1/20.2	010

Notes:

1. Pression statique Max: 14.5 Bar (Pour joint FKM, Pression statique Max: 12 Bar)



Dans cette page	Raccord	Orifice (mm)	Kv (l/min)	Pression Diff. Max. (bar)	Temp. Fluide (°C)	Temp. Amb. (°C)
de	SB	1.3	1	10	-30	-10
à	SB	1.3	1	20	140	50



Schéma 009



Schéma 010

3/2

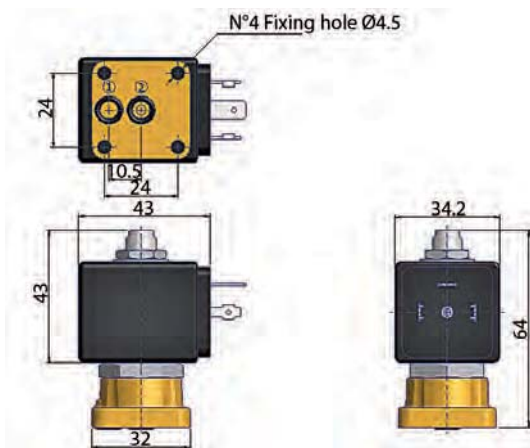
ELECTROVANNES POUR AIR SEC OU LUBRIFIÉ, GAZ ET LIQUIDES NEUTRES COMMANDE DIRECTE

LAITON

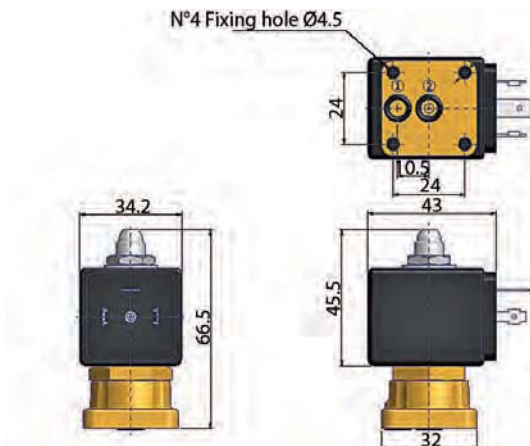
MONTAGE SUR EMBASE

FERMÉE HORS TENSION

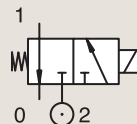

Raccord	Orifice Ø		Facteur d'Écoulement			Pression Différentielle			Temp. Fluide		Joint	Electrovannes PARKER LUCIFER®			IS	Puissance		Groupe Electrique	N° Schéma	
	1	(2)	1	(2)	1	(2)	Min	Max		Min		Max	Ref. Valve	Ref. Boîtier		Ref. Bobine	AC W			DC W
	mm		Kv l/min		KV m³/h		bar	AC bar	DC bar	°C	°C									
SB	1.2	1.5	0.7	0.9	0.042	0.054	0	10	10	-10	75	FKM	131M75	8993	488980	2	2.5	1.1	3383	
	1.2	1.5	0.7	0.9	0.042	0.054	0	10	10	-10	75	FKM	131M7550 ₁	8993	488980	2	2.5	1.1	3383	
	1.5	1.5	0.9	0.9	0.054	0.054	0	7	7	-10	75	FKM	131M74	8993	488980	2	2.5	1.1	3383	
	1.5	1.5	0.9	0.9	0.054	0.054	0	7	7	-10	75	FKM	131M7450 ₁	8993	488980	2	2.5	1.1	3383	
SB	1	1	0.6	0.6	0.036	0.036	0	-	10	-10	75	FKM	131F4490	2995	483580.01	*	-	0.5 to 3	7.0	7057
	1	1	0.6	0.6	0.036	0.036	0	-	10	-10	75	FKM	131F4490	-	488660.01	*	-	0.3 to 3	7.0	7057
	1	1	0.6	0.6	0.036	0.036	0	-	10	-10	75	FKM	131F4490	-	495910	*	-	0.3 to 3	7.0	7057
	1.5	2	1.5	2.2	0.09	0.132	0	-	16	-10	100	FKM	131F4410	2995	481865	-	9	2.1	3509	
	1.5	1.5	1.5	1.5	0.09	0.09	0	-	7	-20	75	PUR	131F4497	2995	482740	-	1.6	6.0/8.0	8022	
	1.5	1.5	1.5	1.5	0.09	0.09	0	7	7	-20	75	PUR	131F4497	-	495900	2.5	2	6.0/8.0	8022	
	1.5	1.5	1.5	1.5	0.09	0.09	0	-	7	-20	75	PUR	131F4497	-	495910	*	-	0.3 to 3	6.0/8.0	8022
	1.5	1.5	1.5	1.5	0.09	0.09	0	-	7	-20	75	PUR	131F4497	2995	496125	-	1.6	6.0/8.0	8022	

Notes:

1. Avec Commande manuelle



Schéma 8022



Dans cette page	Raccord	Orifice (mm)	Kv (l/min)	Pression Diff. Max. (bar)	Temp. Fluide (°C)	Temp. Amb. (°C)
de	SB	1	0.6	7	-20	-20
à	SB	1.5	1.5	16	100	50

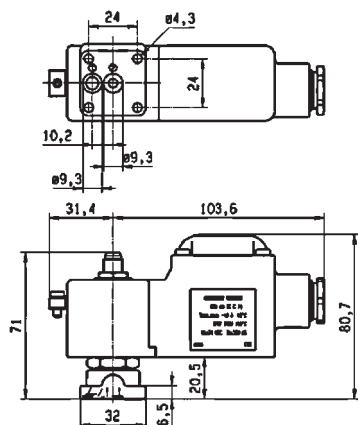

Schéma 3383



WEIGHT: 600g

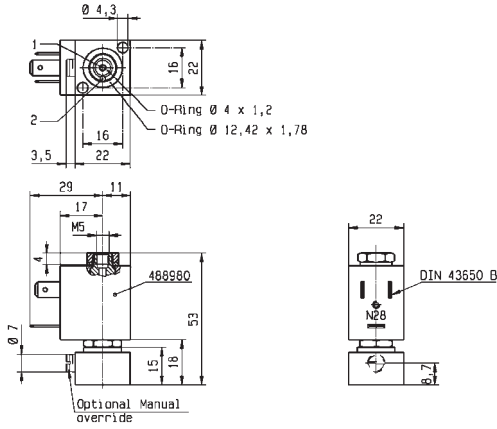
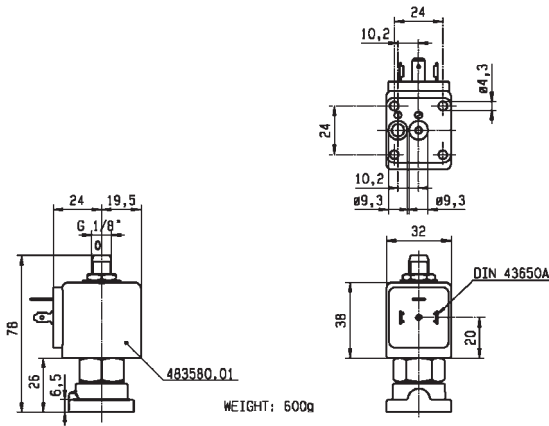

Schéma 7057



Schéma 3509

3/2

ELECTROVANNES POUR AIR SEC OU LUBRIFIÉ, GAZ ET LIQUIDES NEUTRES COMMANDE DIRECTE

LAITON

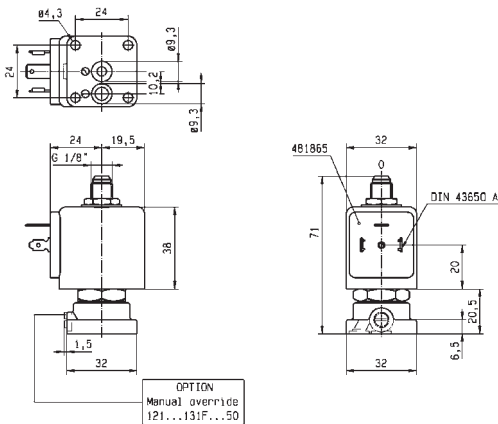
MONTAGE SUR EMBASE

FERMÉE HORS TENSION

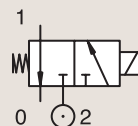

Raccord	Orifice Ø		Facteur d'Écoulement				Pression Différentielle			Temp. Fluide		Joint	Electrovannes PARKER LUCIFER®			Puissance		Groupe Electrique	N° Schéma
	1	(2)	1	(2)	1	(2)	Min	Max		Min	Max		Ref. Valve	Ref. Boîtier	Ref. Bobine	AC W	DC W		
								Kv l/min	DC bar										
SB	1.5	1.5	1.5	1.5	0.09	0.09	0	15	15	-10	100	FKM	E131F44	2995	481865	8	9	2.1	3509
	1.5	1.5	1.5	1.5	0.09	0.09	0	15	15	-10	120	FKM	E131F44	4270	481000	8	8	2.1	3509
	1.5	1.5	1.5	1.5	0.09	0.09	0	15	15	-10	100	FKM	E131F4450 ₁	2995	481865	8	9	2.1	3509
	1.5	1.5	1.5	1.5	0.09	0.09	0	15	15	-10	100	FKM	E131F4450 ₁	4270	481000	8	8	2.1	3509
	2	2.5	2.5	3.5	0.15	0.21	0	10	10	-10	100	FKM	131F46	2995	481865	8	9	2.1	3509
	2	2.5	2.5	3.5	0.15	0.21	0	10	10	-10	120	FKM	131F46	4270	481000	8	8	2.1	3509
	2	2.5	2.5	3.5	0.15	0.21	0	10	10	-10	100	FKM	131F4650 ₁	2995	481865	8	9	2.1	3509
	2	2.5	2.5	3.5	0.15	0.21	0	10	10	-10	120	FKM	131F4650 ₁	4270	481000	8	8	2.1	3509
	2.5	2.5	3.5	3.5	0.21	0.21	0	7	7	-10	100	FKM	E131F43	2995	481865	8	9	2.1	3509
	2.5	2.5	3.5	3.5	0.21	0.21	0	7	7	-10	120	FKM	E131F43	4270	481000	8	8	2.1	3509
	2.5	2.5	3.5	3.5	0.21	0.21	0	7	7	-10	100	FKM	E131F4350 ₁	2995	481865	8	9	2.0	3509
	2.5	2.5	3.5	3.5	0.21	0.21	0	7	7	-10	120	FKM	E131F4350 ₁	4270	481000	8	8	2.0	3509
2.5	2.5	3.5	3.5	0.21	0.21	0	7	7	-10	100	FKM	E131F4350 ₁	4270	486265	14	14	2.0	3509	

Notes:

1. Avec Commande manuelle

LAITON

MONTAGE SUR EMBASE

OUVERTE HORS TENSION

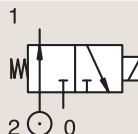

Raccord	Orifice Ø		Facteur d'Écoulement				Pression Différentielle			Temp. Fluide		Joint	Electrovannes PARKER LUCIFER®			Puissance		Groupe Electrique	N° Schéma
	1	(2)	1	(2)	1	(2)	Min	Max		Min	Max		Ref. Valve	Ref. Boîtier	Ref. Bobine	AC W	DC W		
								Kv l/min	DC bar										
SB	1.5	1.5	1.4	1.4	0.084	0.084	0	15	15	-10	75	FKM	132F44	4270	481000	8	8	2.1	3509
	1.5	1.5	1.4	1.4	0.084	0.084	0	15	15	-10	75	FKM	132F44	2995	481865	8	9	2.1	3509
	2	2	1.8	1.8	0.108	0.108	0	10	10	-10	120	FKM	132F46	4270	481000	8	8	2.1	3509
	2	2	1.8	1.8	0.108	0.108	0	10	10	-10	100	FKM	132F46	2995	481865	8	9	2.1	3509
	2.5	2.5	2.2	2.2	0.132	0.132	0	7	7	-10	75	FKM	132F43	4270	481000	8	8	2.0	3509
	2.5	2.5	2.2	2.2	0.132	0.132	0	7	7	-10	75	FKM	132F43	2995	481865	8	9	2.0	3509
	2.5	2.5	2.2	2.2	0.132	0.132	0	7	7	-10	75	FKM	132F43	4270	486265	14	14	2.0	3509

3/2

ELECTROVANNES POUR AIR SEC OU LUBRIFIÉ, GAZ ET LIQUIDES NEUTRES COMMANDE DIRECTE

LAITON

MONTAGE SUR EMBASE

UNIVERSELLE

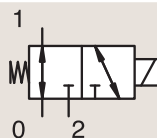

Raccord	Orifice Ø		Facteur d'Écoulement				Pression Différentielle			Temp. Fluide		Joint	Electrovannes PARKER LUCIFER®			Puissance		Groupe Electrique	N° Schéma
	1	(2)	1	(2)	1	(2)	Min	Max		Min	Max		Ref. Valve	Ref. Boîtier	Ref. Bobine	AC W	DC W		
	mm		Kv l/min		KV m³/h		bar	AC bar	DC bar	°C	°C								
SB	1.5	1.5	1.5	1.5	0.09	0.09	0	10	10	-10	100	FKM	E133F4450	4270	481000	8	8	2.1	3509
	1.5	1.5	1.5	1.5	0.09	0.09	0	10	10	-10	120	FKM	E133F4450	2995	481865	8	9	2.1	3509
SB	1.5	1.5	1.5	1.5	0.09	0.09	0	10	10	-10	120	FKM	E133F44	4270	481000	8	8	2.1	3509
	1.5	1.5	1.5	1.5	0.09	0.09	0	10	10	-10	100	FKM	E133F44	2995	481865	8	9	2.1	3509
	2	2	2.5	2.5	0.15	0.15	0	7	7	-10	120	FKM	133F46	4270	481000	8	8	2.1	3509
	2	2	2.5	2.5	0.15	0.15	0	7	7	-10	100	FKM	133F46	2995	481865	8	9	2.1	3509
	2.5	2.5	3.5	3.5	0.21	0.21	0	4	4	-10	120	FKM	E133F43	4270	481000	8	8	2.1	3509
	2.5	2.5	3.5	3.5	0.21	0.21	0	4	4	-10	100	FKM	E133F43	2995	481865	8	9	2.1	3509

Notes:

1. Avec Commande manuelle

3/2

ELECTROVANNES POUR AIR SEC OU LUBRIFIÉ, GAZ ET LIQUIDES NEUTRES COMMANDE DIRECTE

ALUMINIUM ANODISÉ

BANJO

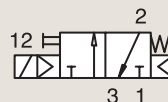

FERMÉE HORS TENSION

Raccord	Orifice Ø 1	Facteur d'Écoulement Qn l/min	Pression Différentielle			Temp. Fluide		Joint	Electrovannes PARKER LUCIFER®			Puissance		Groupe Electrique	N° Schéma
			Min bar	Max AC bar DC bar		Min °C	Max °C		Ref. Valve	Ref. Boîtier	Ref. Bobine	AC W	DC W		
1/8"	1.2	50	0	10	10	-10	50	NBR	131B04 ₁₂	-	496131	3	3	1.2	8226
	1.2	50	0	10	10	-10	50	NBR	131B04 ₁₂	-	496482	3	3	1.2	8226
	1.2	50	0	10	10	-10	50	NBR	131B04 ₁₂	-	496637	3	3	1.2	8226
	1.2	50	0	10	10	-10	50	NBR	131B14 ₁₂	-	496131	3	3	1.2	8227
	1.2	50	0	10	10	-10	50	NBR	131B14 ₁₂	-	496482	3	3	1.2	8227
	1.2	50	0	10	10	-10	50	NBR	131B14 ₁₂	-	496637	3	3	1.2	8227

Notes:

1. Avec Commande manuelle
2. Valve uniquement compatible avec air et gaz neutres



Dans cette page	Raccord	Orifice (mm)	Qn (l/min)	Pression Diff. Max. (bar)	Temp. Fluide (°C)	Temp. Amb. (°C)
de	1/8"	1.2	50	10	-10	-10
à	1/8"	1.2	50	10	50	50



Schéma 8226



Schéma 8227

3/2

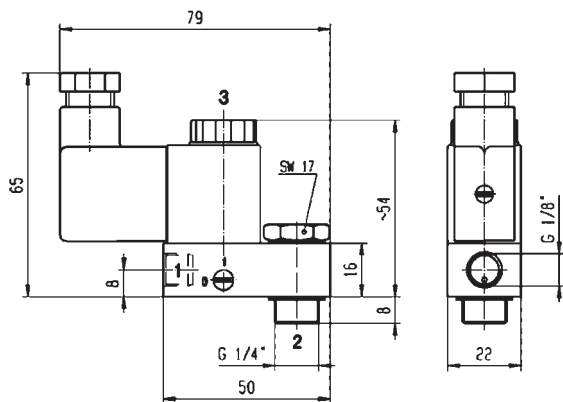
ELECTROVANNES POUR AIR SEC OU LUBRIFIÉ,
GAZ ET LIQUIDES NEUTRES
COMMANDE DIRECTE

INOX 303

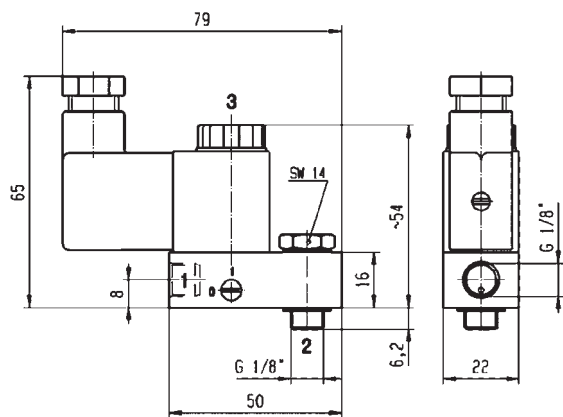
MONTAGE SUR EMBASE

FERMÉE HORS TENSION

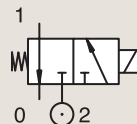

Raccord	Orifice Ø		Facteur d'Écoulement		Pression Différentielle			Temp. Fluide		Joint	Electrovannes PARKER LUCIFER®			Puissance		Groupe Electrique	N° Schéma		
	1	(2)	1	(2)	Min	Max		Min	Max		Ref. Valve	Ref. Boîtier	Ref. Bobine	AC	DC				
	mm		Kv l/min	KV m³/h	bar	AC bar	DC bar	°C	°C					W	W				
SB	1.5	1.5	1.5	2.2	0.09	0.132	0	15	15	-10	100	NBR	131F5406	2995	481865	8	9	2.1	3509

3/2

ELECTROVANNES POUR AIR SEC OU LUBRIFIÉ, GAZ ET LIQUIDES NEUTRES COMMANDE DIRECTE

POM

MONTAGE SUR EMBASE

FERMÉE HORS TENSION

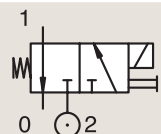

Raccord	Orifice Ø		Facteur d'Écoulement				Pression Différentielle			Temp. Fluide		Joint	Electrovannes PARKER LUCIFER®			Puissance		Groupe Electrique	N° Schéma
	1	(2)	1	(2)	1	(2)	Min	Max		Min	Max		Ref. Valve	Ref. Boîtier	Ref. Bobine	AC W	DC W		
	mm		Kv l/min		KV m³/h		bar	AC bar	DC bar	°C	°C								
SB	2	2	2	2	0.12	0.12	0	10	10	-10	50	FKM	E131F26 ₁₂	2995	481865	8	9	2.1/3.0	3601
	2	2	2	2	0.12	0.12	0	10	10	-10	50	FKM	E131F26 ₂	2995	482730	6	7	2.1/3.0	3601

Notes:

1. Le temps d'enclenchement est de 2 minutes maximum. Le temps d'enclenchement ne doit pas dépasser 20% du temps de cycle complet de la valve.
2. Avec commande manuelle



Dans cette page	Raccord	Orifice (mm)	Kv (l/min)	Pression Diff. Max. (bar)	Temp. Fluide (°C)	Temp. Amb. (°C)
de	SB	2	2	10	-10	-10
à	SB	2	2	10	50	50



Schéma 3601

3/2

ELECTROVANNES POUR AIR SEC OU LUBRIFIÉ, GAZ ET LIQUIDES NEUTRES SERVO-COMMANDE

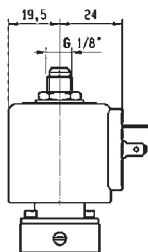
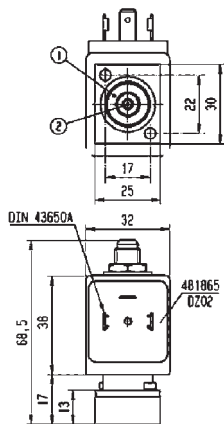

Equipement Industriel



Process

ALUMINIUM ANODISÉ RACCORD TUYAU

FERMÉE HORS TENSION

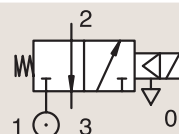

Raccord	Orifice Ø		Facteur d'Écoulement			Pression Différentielle			Temp. Fluide		Joint	Electrovannes PARKER LUCIFER®			IS	Puissance		Groupe Electrique	N° Schéma	
	1	(2)	1	(2)	1	(2)	Min	Max	Min	Max		Ref. Valve	Ref. Boîtier	Ref. Bobine		AC W	DC W			
BSP	mm		Kv		KV		bar	AC bar	DC bar	°C	°C									
1/4"	6.5	6.5	10	-	0.6	-	1	-	10	-10	55	NBR	331B7490 ₂	2995	483580.01	*	-	0.5 to 3	7.0/8.0	8270
	6.5	6.5	10	-	0.6	-	1	-	10	-10	75	NBR	331B7490 ₂	-	488660.01	*	-	0.3 to 3	7.0/8.0	8270
	6.5	6.5	10	-	0.6	-	1	-	10	-10	75	NBR	331B7490 ₂	-	495910	*	-	0.3 to 3	7.0/8.0	8270
	6.5	-	10	-	0.6	-	1	10	10	-10	75	NBR	E331B74 ₁₂	2995	481865		8	9	2.1	3240
	6.5	-	10	-	0.6	-	1	10	10	-10	75	NBR	E331B74 ₁₂	4270	485100		8	8	2.1	3240
	8	8	20	20	1.2	1.2	1	15	15	-10	75	FKM	E331B01 ₃	4270	481000		8	8	2.1	3234
	8	8	20	20	1.2	1.2	1	15	15	-10	75	FKM	E331B01 ₃	2995	481865		8	9	2.1	3234
	8	8	20	20	1.2	1.2	1	15	15	-10	75	FKM	E331B01 ₃	-	483371		8	8	2.1	3234

Notes:

- 1. Avec Commande manuelle
- 2. Valve uniquement compatible avec air et gaz neutres
- 3. Valve uniquement compatible avec huile hydraulique, air et gaz neutres



Dans cette page	Raccord	Orifice (mm)	Kv (l/min)	Pression Diff. Max. (bar)	Temp. Fluide (°C)	Temp. Amb. (°C)
de	1/4"	6.5	10	10	-10	-10
à	1/4"	8	20	15	75	50



Schéma 8270



Weight: 0,51 kg

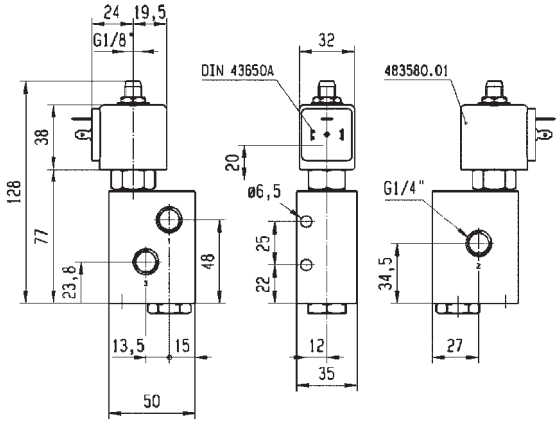
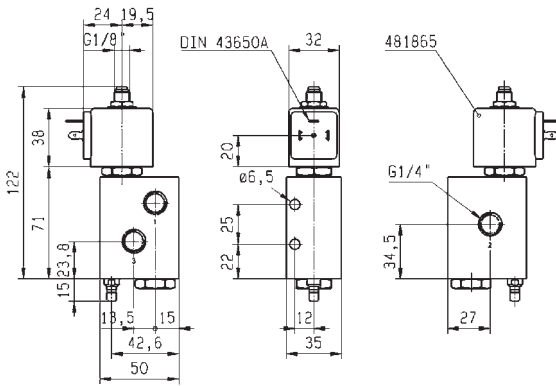

Schéma 3240

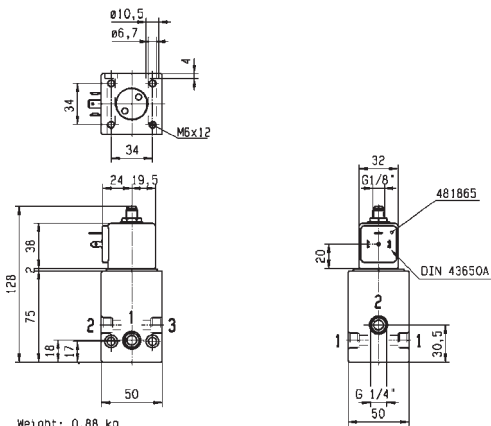

Weight: 0,88 kg



Schéma 3234

3/2

ELECTROVANNES POUR AIR SEC OU LUBRIFIÉ, GAZ ET LIQUIDES NEUTRES SERVO-COMMANDE

ALUMINIUM ANODISÉ
RACCORD TUYAU

FERMÉE HORS TENSION

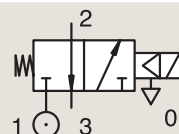

Raccord	Orifice Ø		Facteur d'Écoulement				Pression Différentielle			Temp. Fluide		Joint	Electrovannes PARKER LUCIFER®			Puissance		Groupe Electrique	N° Schéma
	1	(2)	1	(2)	1	(2)	Min	Max		Min	Max		Ref. Valve	Ref. Boîtier	Ref. Bobine	AC W	DC W		
BSP	mm		Kv l/min		KV m³/h		bar	AC bar	DC bar	°C	°C								
1/2"	14	14	-	-	-	-	1	15	-	-10	75	FKM	E331B21 ₁	2995	482722	10	-	2.1	3238
	14	14	-	-	-	-	1	15	15	-10	75	FKM	E331B21 ₁	-	483371	8	8	2.1	3238

Notes:

1.Valve uniquement compatible avec air et gaz neutres

ALUMINIUM ANODISÉ
RACCORD TUYAU

OUVERTE HORS TENSION

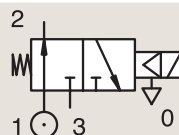

Raccord	Orifice Ø		Facteur d'Écoulement				Pression Différentielle			Temp. Fluide		Joint	Electrovannes PARKER LUCIFER®			Puissance		Groupe Electrique	N° Schéma
	1	(2)	1	(2)	1	(2)	Min	Max		Min	Max		Ref. Valve	Ref. Boîtier	Ref. Bobine	AC W	DC W		
BSP	mm		Kv l/min		KV m³/h		bar	AC bar	DC bar	°C	°C								
1/4"	8	8	10	10	0.6	0.6	1	40	40	-10	75	NBR	332B02 ₁₂	2995	481865	8	9	2.1	8114
	8	8	10	10	0.6	0.6	1	40	40	-10	75	NBR	332B02 ₁₂	4270	481000	8	8	2.1	8114
	8	8	20	20	1.2	1.2	1	15	15	-10	75	FKM	E332B01 ₂	2995	481865	8	9	2.1	3234
	8	8	20	20	1.2	1.2	1	15	15	-10	75	FKM	E332B01 ₂	4270	481000	8	8	2.1	3234
	8	8	20	20	1.2	1.2	1	15	15	-10	75	FKM	E332B01 ₂	-	483371	8	8	2.1	3234

Notes:

1.Valve avec conduite de retour de pilote intégrée

2.Valve uniquement compatible avec huile hydraulique, air et gaz neutres



Dans cette page	Raccord	Orifice (mm)	Kv (l/min)	Pression Diff. Max. (bar)	Temp. Fluide (°C)	Temp. Amb. (°C)
de	1/4"	8	10	15	-10	-10
à	1/2"	14	20	40	75	50

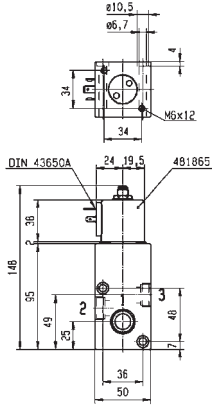

Weight: 0,98 ka



Schéma 3238



Weight: 0,88 kg

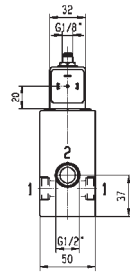
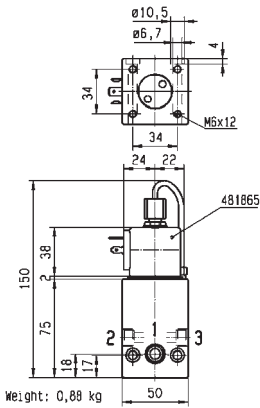

Schéma 8114



Weight: 0,88 ka

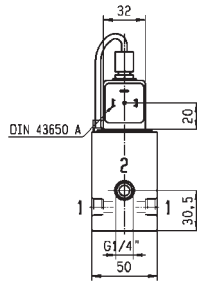
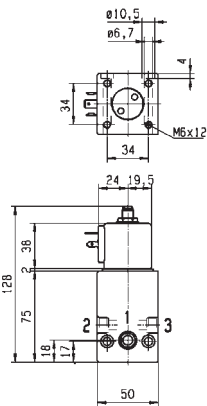

Schéma 3234

3/2

ELECTROVANNES POUR AIR SEC OU LUBRIFIÉ, GAZ ET LIQUIDES NEUTRES SERVO-COMMANDE

ALUMINIUM ANODISÉ

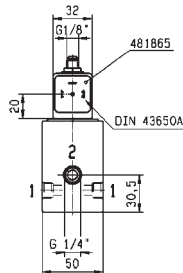
RACCORD TUYAU

OUVERTE HORS TENSION

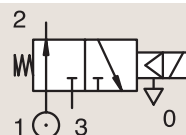

Raccord	Orifice Ø		Facteur d'Écoulement			Pression Différentielle			Temp. Fluide		Joint	Electrovannes PARKER LUCIFER®			Puissance		Groupe Electrique	N° Schéma	
	1	(2)	1	(2)	1	(2)	Min	Max	Min	Max		Ref. Valve	Ref. Boîtier	Ref. Bobine	AC W	DC W			
BSP	mm		Kv l/min		KV m³/h		AC bar	DC bar	°C	°C									
1/2"	14	14	-	-	-	-	1	15	15	-10	100	FKM	E332B21 ₁	2995	481865	8	9	2.1	3238
	14	14	-	-	-	-	1	15	15	-10	100	FKM	E332B21 ₁	4270	481000	8	8	2.1	3238

Notes:

1.Valve uniquement compatible avec air et gaz neutres

ALUMINIUM ANODISÉ

MONTAGE SUR EMBASE

FERMÉE HORS TENSION

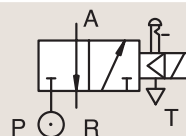

Raccord	Orifice Ø	Facteur d'Écoulement	Pression Différentielle			Temp. Fluide		Joint	Electrovannes PARKER LUCIFER®			Puissance		Groupe Electrique	N° Schéma
	1		Min	Max	Min	Max	Ref. Valve		Ref. Boîtier	Ref. Bobine	AC W	DC W			
SB	mm	Qn l/min	bar	AC bar	DC bar	°C	°C								
SB	15	5000	0.5	10	10	-10	75	FKM	E331L21 ₁	2995	481865	8	9	2.1/3.0	3130
	15	5000	0.5	10	10	-10	75	FKM	E331L21 ₁	-	483371	8	8	2.1/3.0	3130

Notes:

1.Avec Commande manuelle



Dans cette page	Raccord	Orifice (mm)	Qn (l/min)	Pression Diff. Max. (bar)	Temp. Fluide (°C)	Temp. Amb. (°C)
de	1/2"	14	-	10	-10	-10
à	1/2"	15	5000	15	100	50

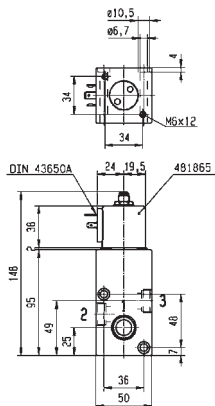

Weight: 0,98 ka



Schéma 3238



Schéma 3130

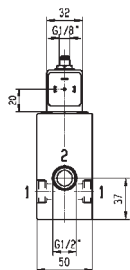

ELECTROVANNES POUR HUILE HYDRAULIQUE ET LIQUIDES NEUTRES (MAX. 75 BAR)

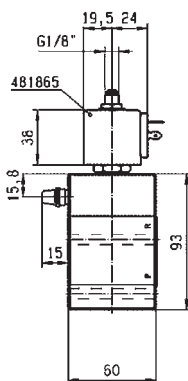
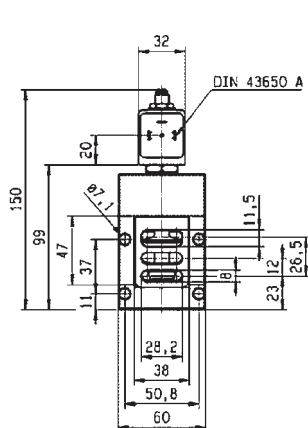

Huile



Eau

3/2

Commande	Corps de Valve	Fonction	Raccord	Orifice (mm)	Facteur d'Écoulement Kv(l/min)	Pression Différentielle (bar)	Temp. Max. Fluide (°C)	Page Valves Parker	Page Valves Parker LUCIFER®
Servo-commande	Aluminium anodisé/ Raccord tuyau	Fermée hors tension	1/4"	8	10	40	75	-	248

3/2

ELECTROVANNES POUR HUILE HYDRAULIQUE ET LIQUIDES NEUTRES (MAX. 75 BAR) SERVO-COMMANDE



Process



Equipement Industriel

ALUMINIUM ANODISÉ RACCORD TUYAU

FERMÉE HORS TENSION

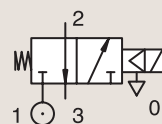

Raccord	Orifice Ø		Facteur d'Écoulement				Pression Différentielle			Temp. Fluide		Joint	Electrovannes PARKER LUCIFER®			Puissance		Groupe Electrique	N° Schéma
	1	(2)	1	(2)	1	(2)	Min	Max	Max	Min	Max		Ref. Valve	Ref. Boîtier	Ref. Bobine	AC W	DC W		
BSP	mm		Kv l/min		KV m³/h		bar	AC bar	DC bar	°C	°C								
1/4"	8	8	10	10	0.6	0.6	1	40	40	-10	75	NBR	331B02 ₁	2995	481865	8	9	2.1	8114
	8	8	10	10	0.6	0.6	1	40	40	-10	75	NBR	331B02 ₁	4270	481000	8	8	2.1	8114

Notes:

1. Joint du clapet de pilotage en PCTFE ; valve avec conduite de retour de pilote intégrée



Dans cette page	Raccord	Orifice (mm)	Kv (l/min)	Pression Diff. Max. (bar)	Temp. Fluide (°C)	Temp. Amb. (°C)
de	1/4"	8	10	40	-10	-10
à	1/4"	8	10	40	75	50



Schéma 8114



ELECTROVANNES HAUTEMENT RESISTANTES À LA CORROSION (INOX 303)

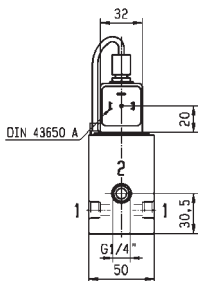
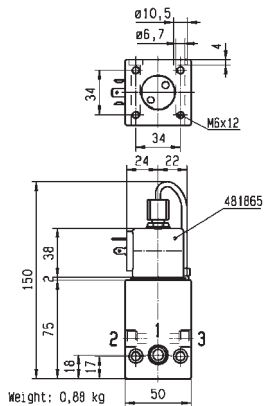

3/2

Commande	Corps de Valve	Fonction	Raccord	Orifice (mm)	Facteur d'Écoulement Kv(l/min)	Pression Différentielle (bar)	Temp. Max. Fluide (°C)	Page Valves Parker	Page Valves Parker LUCIFER®
Commande Directe	Inox 303 /Raccord tuyau	Fermée hors tension	1/4"	1 à 2.5	3.5	15	180	-	252
			1/4"	1 à 2.5	3.5	15	180	-	252
		Universelle	1/4"	1.5 à 2.5	3.5	10	180	-	254

3/2

ELECTROVANNES HAUTEMENT RESISTANTES À LA CORROSION (INOX 303) COMMANDE DIRECTE



Process

INOX 303 RACCORD TUYAU

FERMÉE HORS TENSION

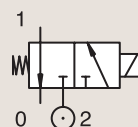

Raccord	Orifice Ø		Facteur d'Écoulement				Pression Différentielle			Temp. Fluide		Joint	Electrovannes PARKER LUCIFER®			IS	Puissance		Groupe Electrique	N° Schéma
	1	(2)	1	(2)	1	(2)	Min	Max	Max	Min	Max		Ref. Valve	Ref. Boîtier	Ref. Bobine		AC W	DC W		
BSP	mm		Kv l/min		KV m³/h		bar	AC bar	DC bar	°C	°C									
1/4"	1	1	0.6	0.6	0.036	0.036	0	-	10	-10	55	FKM	131V5490	2995	483580.01	*	-	0.5 to 3	7.0	6740
	1	1	0.6	0.6	0.036	0.036	0	-	10	-10	75	FKM	131V5490	-	488660.01	*	-	0.3 to 3	7.0	6740
	1	1	0.6	0.6	0.036	0.036	0	-	10	-10	75	FKM	131V5490	-	495910	*	-	0.3 to 3	7.0	6740
	1.5	1.5	1.5	1.5	0.09	0.09	0	15	15	-10	120	FKM	131V5406	4270	481000		8	8	2.1	8116
	1.5	1.5	1.5	1.5	0.09	0.09	0	15	15	-10	100	FKM	131V5406	2995	481865		8	9	2.1	8116
	1.5	1.5	1.5	1.5	0.09	0.09	0	15	15	0	130	Ruby	131V5463 ₁	4270	481000		8	8	2.0	8116
	1.5	1.5	1.5	1.5	0.09	0.09	0	15	15	0	100	Ruby	131V5463 ₁	2995	481865		8	9	2.0	8116
	1.5	1.5	1.5	1.5	0.09	0.09	0	15	15	0	180	Ruby	131V5463 ₁	4270	486265		14	14	2.0	8116
	1.5	1.5	1.5	1.5	0.09	0.09	0	-	7	-20	75	PUR	131V5497	2995	482740		-	1.6	3.0/6.0/8.0	8024
	1.5	1.5	1.5	1.5	0.09	0.09	0	7	7	-20	75	PUR	131V5497	-	495900		2.5	2	3.0/6.0/8.0	8024
	1.5	1.5	1.5	1.5	0.09	0.09	0	-	7	-20	75	PUR	131V5497	-	495910	*	-	0.3 to 3	3.0/6.0/8.0	8024
	1.5	1.5	1.5	1.5	0.09	0.09	0	-	7	-20	75	PUR	131V5497	2995	496125		-	1.6	3.0/6.0/8.0	8024
	2.5	2.5	3.5	3.5	0.21	0.21	0	7	7	-10	120	FKM	131V5306	4270	481000		8	8	2.1	8116
	2.5	2.5	3.5	3.5	0.21	0.21	0	7	7	-10	100	FKM	131V5306	2995	481865		8	9	2.1	8116
	2.5	2.5	3.5	3.5	0.21	0.21	0	7	7	-30	130	Ruby	131V5363 ₁	4270	481000		8	8	2.0	8116
	2.5	2.5	3.5	3.5	0.21	0.21	0	7	7	-30	100	Ruby	131V5363 ₁	2995	481865		8	9	2.0	8116
	2.5	2.5	3.5	3.5	0.21	0.21	0	7	7	-30	180	Ruby	131V5363 ₁	4270	486265		14	14	2.0	8116
	2.5	2.5	3	3	0.18	0.18	0	-	2	-20	75	PUR	131V5397	2995	482740		-	1.6	6.0/8.0	8024
	2.5	2.5	3	3	0.18	0.18	0	2	2	-20	75	PUR	131V5397	-	495900		2.5	2	6.0/8.0	8024
	2.5	2.5	3	3	0.18	0.18	0	-	2	-20	75	PUR	131V5397	-	495910	*	-	0.3 to 3	6.0/8.0	8024
2.5	2.5	3	3	0.18	0.18	0	-	2	-20	75	PUR	131V5397	2995	496125		-	1.6	6.0/8.0	8024	

Notes:

1. Valve uniquement compatible avec huile hydraulique et liquides neutres



Dans cette page	Raccord	Orifice (mm)	Kv (l/min)	Pression Diff. Max. (bar)	Temp. Fluide (°C)	Temp. Amb. (°C)
de	1/4"	1	0.6	2	-30	-20
à	1/4"	2.5	3.5	15	180	50

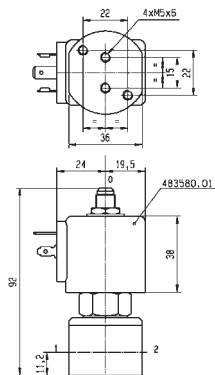

WEIGHT: 0.410 Kg



Schéma 6740



A G 1/8"
G 1/4"

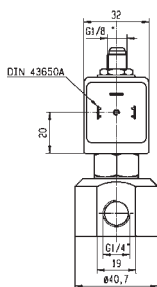
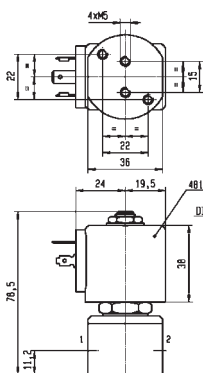

Schéma 8116



Schéma 8024

3/2

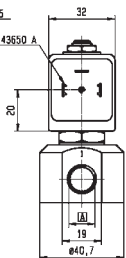
ELECTROVANNES HAUTEMENT RESISTANTES À LA CORROSION (INOX 303) COMMANDE DIRECTE

INOX 303

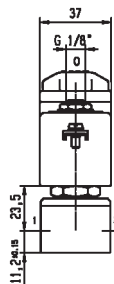
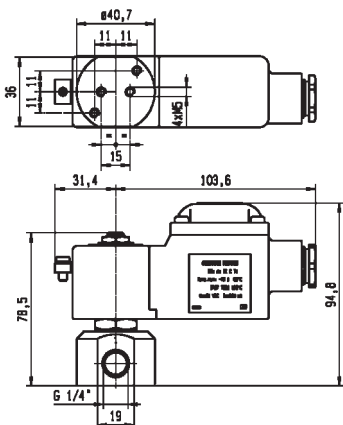
RACCORD TUYAU

UNIVERSELLE

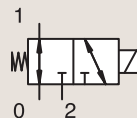

Raccord	Orifice Ø		Facteur d'Écoulement			Pression Différentielle			Temp. Fluide		Joint	Electrovannes PARKER LUCIFER®			Puissance		Groupe Électrique	N° Schéma	
	1	(2)	1	(2)	1	(2)	Min	Max	Min	Max		Ref. Valve	Ref. Boîtier	Ref. Bobine	AC W	DC W			
BSP	mm		Kv l/min		KV m³/h	bar	AC bar	DC bar	°C	°C									
1/4"	1.5	1.5	1.5	1.5	0.09	0.09	0	10	10	-10	120	FKM	133V5406	4270	481000	8	8	2.1	8116
	1.5	1.5	1.5	1.5	0.09	0.09	0	10	10	-10	100	FKM	133V5406	2995	481865	8	9	2.1	8116
	1.5	1.5	1.5	1.5	0.09	0.09	0	10	10	0	130	Ruby	133V5463 ₁	4270	481000	8	8	2.0	8116
	1.5	1.5	1.5	1.5	0.09	0.09	0	4	4	0	100	Ruby	133V5463 ₁	2995	481865	8	9	2.0	8116
	1.5	1.5	1.5	1.5	0.09	0.09	0	10	10	0	180	Ruby	133V5463 ₁	4270	486265	14	14	2.0	8116
	2.5	2.5	3.5	3.5	0.21	0.21	0	4	4	-10	120	FKM	133V5306	4270	481000	8	8	2.1	8116
	2.5	2.5	3.5	3.5	0.21	0.21	0	4	4	-10	100	FKM	133V5306	2995	481865	8	9	2.1	8116
	2.5	2.5	3.5	3.5	0.21	0.21	0	4	4	0	130	Ruby	133V5363 ₁	4270	481000	8	8	2.0	8116
	2.5	2.5	3.5	3.5	0.21	0.21	0	4	4	0	100	Ruby	133V5363 ₁	2995	481865	8	9	2.0	8116
	2.5	2.5	3.5	3.5	0.21	0.21	0	4	4	0	180	Ruby	133V5363 ₁	4270	486265	14	14	2.0	8116

Notes:

1.Valve uniquement compatible avec huile hydraulique et liquides neutres



Dans cette page	Raccord	Orifice (mm)	Kv (l/min)	Pression Diff. Max. (bar)	Temp. Fluide (°C)	Temp. Amb. (°C)
de	1/4"	1.5	1.5	4	-10	-10
à	1/4"	2.5	3.5	10	180	50

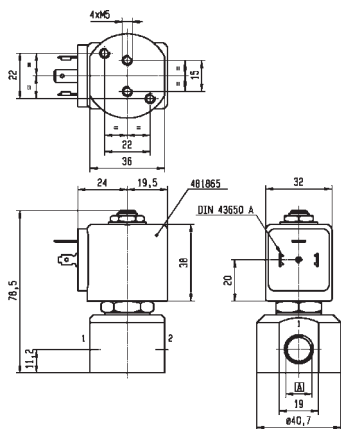

A	G 1/8"
	G 1/4"



Schéma 8116



ELECTROVANNES POUR DISTRIBUTION DE BOISSONS LIQUIPURE®



Vapeur



Eau

3/2

Commande	Corps de Valve	Fonction	Raccord	Orifice (mm)	Facteur d'Écoulement Kv(l/min)	Pression Différentielle (bar)	Temp. Max. Fluide (°C)	Page Valves Parker
Commande Directe	Inox /Montage sur embase	Fermée hors tension	SB	1.5 à 3	4.2	14	140	258

3/2

ELECTROVANNES POUR DISTRIBUTION DE BOISSONS - LIQUIPURE® COMMANDE DIRECTE



Distribution de Boissons



Médical / Instrumentation

INOX MONTAGE SUR EMBASE

FERMÉE HORS TENSION

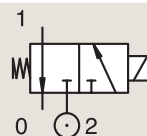

Raccord	Orifice Ø		Facteur d'Écoulement				Pression Différentielle			Temp. Fluide		Joint	Electrovannes PARKER			Puissance		Groupe Electrique	N° Schéma
	1	(2)	1	(2)	1	(2)	Min	Max		Min	Max		Ref. Valve	Ref. Boîtier	Ref. Bobine	AC W	DC W		
								mm	Kv l/min										
SB	1.5	2.5	1.3	-	0.08	-	0	14	14	-10	140	Ruby	3019F1GRG7	-	D4	13	16	24.0	072
	1.5	2.5	1.3	-	0.08	-	0	14	14	-10	140	Ruby	3019F1GRG7	-	D5	8	9	24.0	072
	1.5	2.5	1.3	-	0.08	-	0	14	14	-10	140	Ruby	3019F1GRG7	-	LA	9	9	24.0	072
	1.5	2.5	1.3	-	0.08	-	0	14	14	-10	140	Ruby	3019F1GRG7	-	LB-LC	13	16	24.0	072
	1.5	2.5	1.3	-	0.08	-	0	14	-	-10	140	Ruby	3019F1GRG7	-	XS03	9	-	24.0	072
	1.5	2.5	1.3	-	0.08	-	0	14	14	-10	140	FDA FKM	3019F1GVG7	-	D4	13	16	24.0	072
	1.5	2.5	1.3	-	0.08	-	0	14	14	-10	140	FDA FKM	3019F1GVG7	-	D5	8	9	24.0	072
	1.5	2.5	1.3	-	0.08	-	0	14	14	-10	140	FDA FKM	3019F1GVG7	-	LA	9	9	24.0	072
	1.5	2.5	1.3	-	0.08	-	0	14	14	-10	140	FDA FKM	3019F1GVG7	-	LB-LC	13	16	24.0	072
	1.5	2.5	1.3	-	0.08	-	0	14	-	-10	140	FDA FKM	3019F1GVG7	-	XS03	9	-	24.0	072
	1.5	2.5	1.3	-	0.08	-	0	14	14	-10	140	Ruby	301XGFRTG7	-	D4	13	16	24.0	073
	1.5	2.5	1.3	-	0.08	-	0	14	14	-10	140	Ruby	301XGFRTG7	-	D5	8	9	24.0	073
	1.5	2.5	1.3	-	0.08	-	0	14	14	-10	140	Ruby	301XGFRTG7	-	LA	9	9	24.0	073
	1.5	2.5	1.3	-	0.08	-	0	14	14	-10	140	Ruby	301XGFRTG7	-	LB-LC	13	16	24.0	073
	1.5	2.5	1.3	-	0.08	-	0	14	-	-10	140	Ruby	301XGFRTG7	-	XS03	9	-	24.0	073
	1.5	2.5	1.3	-	0.08	-	0	14	14	-10	140	FDA FKM	301XGFVTG7	-	D4	13	16	24.0	073
	1.5	2.5	1.3	-	0.08	-	0	14	14	-10	140	FDA FKM	301XGFVTG7	-	D5	8	9	24.0	073
	1.5	2.5	1.3	-	0.08	-	0	14	14	-10	140	FDA FKM	301XGFVTG7	-	LA	9	9	24.0	073
	1.5	2.5	1.3	-	0.08	-	0	14	14	-10	140	FDA FKM	301XGFVTG7	-	LB-LC	13	16	24.0	073
	1.5	2.5	1.3	-	0.08	-	0	14	-	-10	140	FDA FKM	301XGFVTG7	-	XS03	9	-	24.0	073
2	2.5	2.2	-	0.13	-	0	10	10	-10	140	Ruby	3019F1JRG7	-	D4	13	16	24.0	072	
2	2.5	2.2	-	0.13	-	0	10	10	-10	140	Ruby	3019F1JRG7	-	D5	8	9	24.0	072	
2	2.5	2.2	-	0.13	-	0	10	10	-10	140	Ruby	3019F1JRG7	-	LA	9	9	24.0	072	
2	2.5	2.2	-	0.13	-	0	10	10	-10	140	Ruby	3019F1JRG7	-	LB-LC	13	16	24.0	072	



Dans cette page	Raccord	Orifice (mm)	Kv (l/min)	Pression Diff. Max. (bar)	Temp. Fluide (°C)	Temp. Amb. (°C)
de	SB	1.5	1.3	10	-10	-10
à	SB	2	2.2	14	140	50



Schéma 072



Schéma 073

3/2

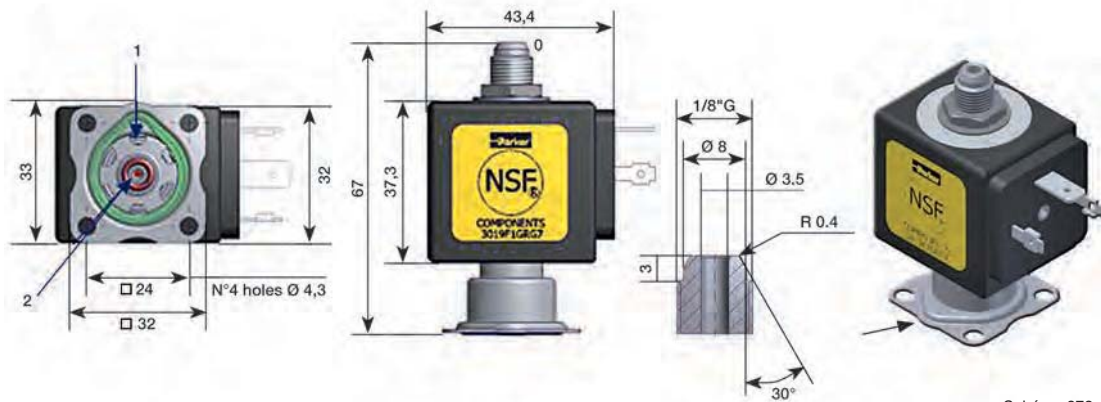
ELECTROVANNES POUR DISTRIBUTION DE BOISSONS - LIQUIPURE® COMMANDE DIRECTE

INOX

MONTAGE SUR EMBASE

FERMÉE HORS TENSION

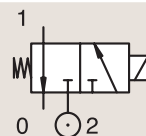

Raccord	Orifice Ø			Facteur d'Écoulement			Pression Différentielle			Temp. Fluide		Joint	Electrovannes PARKER			Puissance		Groupe Electrique	N° Schéma
	1	(2)		1	(2)		Min	Max		Min	Max		Ref. Valve	Ref. Boîtier	Ref. Bobine	AC W	DC W		
	mm			Kv			bar	AC bar	DC bar	°C	°C								
SB	2	2.5	2.2	-	0.13	-	0	10	-	-10	140	Ruby	3019F1JRG7	-	XS03	9	-	24.0	072
	2	2.5	2.2	-	0.13	-	0	10	10	-10	140	FDA FKM	3019F1JVG7	-	D4	13	16	24.0	072
	2	2.5	2.2	-	0.13	-	0	10	10	-10	140	FDA FKM	3019F1JVG7	-	D5	8	9	24.0	072
	2	2.5	2.2	-	0.13	-	0	10	10	-10	140	FDA FKM	3019F1JVG7	-	LA	9	9	24.0	072
	2	2.5	2.2	-	0.13	-	0	10	10	-10	140	FDA FKM	3019F1JVG7	-	LB-LC	13	16	24.0	072
	2	2.5	2.2	-	0.13	-	0	10	-	-10	140	FDA FKM	3019F1JVG7	-	XS03	9	-	24.0	072
	2	2.5	2.2	-	0.13	-	0	10	10	-10	140	Ruby	301XGFRTJ7	-	D4	13	16	24.0	073
	2	2.5	2.2	-	0.13	-	0	10	10	-10	140	Ruby	301XGFRTJ7	-	D5	8	9	24.0	073
	2	2.5	2.2	-	0.13	-	0	10	10	-10	140	Ruby	301XGFRTJ7	-	LA	9	9	24.0	073
	2	2.5	2.2	-	0.13	-	0	10	10	-10	140	Ruby	301XGFRTJ7	-	LB-LC	13	16	24.0	073
	2	2.5	2.2	-	0.13	-	0	10	-	-10	140	Ruby	301XGFRTJ7	-	XS03	9	-	24.0	073
	2	2.5	2.2	-	0.13	-	0	10	10	-10	140	FDA FKM	301XGFVTJ7	-	D4	13	16	24.0	073
	2	2.5	2.2	-	0.13	-	0	10	10	-10	140	FDA FKM	301XGFVTJ7	-	D5	8	9	24.0	073
	2	2.5	2.2	-	0.13	-	0	10	10	-10	140	FDA FKM	301XGFVTJ7	-	LA	9	9	24.0	073
	2	2.5	2.2	-	0.13	-	0	10	10	-10	140	FDA FKM	301XGFVTJ7	-	LB-LC	13	16	24.0	073
	2	2.5	2.2	-	0.13	-	0	10	-	-10	140	FDA FKM	301XGFVTJ7	-	XS03	9	-	24.0	073
	2.5	2.5	2.8	-	0.17	-	0	6.5	6.5	-10	140	Ruby	3019F1LRG7	-	D4	13	16	24.0	072
	2.5	2.5	2.8	-	0.17	-	0	6.5	6.5	-10	140	Ruby	3019F1LRG7	-	D5	8	9	24.0	072
	2.5	2.5	2.8	-	0.17	-	0	6.5	6.5	-10	140	Ruby	3019F1LRG7	-	LA	9	9	24.0	072
	2.5	2.5	2.8	-	0.17	-	0	6.5	6.5	-10	140	Ruby	3019F1LRG7	-	LB-LC	13	16	24.0	072
	2.5	2.5	2.8	-	0.17	-	0	6.5	-	-10	140	Ruby	3019F1LRG7	-	XS03	9	-	24.0	072
	2.5	2.5	2.8	-	0.17	-	0	6.5	6.5	-10	140	FDA FKM	3019F1LVG7	-	D4	13	16	24.0	072
	2.5	2.5	2.8	-	0.17	-	0	6.5	6.5	-10	140	FDA FKM	3019F1LVG7	-	D5	8	9	24.0	072
	2.5	2.5	2.8	-	0.17	-	0	6.5	6.5	-10	140	FDA FKM	3019F1LVG7	-	LA	9	9	24.0	072
	2.5	2.5	2.8	-	0.17	-	0	6.5	6.5	-10	140	FDA FKM	3019F1LVG7	-	LB-LC	13	16	24.0	072
	2.5	2.5	2.8	-	0.17	-	0	6.5	-	-10	140	FDA FKM	3019F1LVG7	-	XS03	9	-	24.0	072
	2.5	2.5	2.8	-	0.17	-	0	6.5	6.5	-10	140	Ruby	301XGFRTL7	-	D4	13	16	24.0	073
	2.5	2.5	2.8	-	0.17	-	0	6.5	6.5	-10	140	Ruby	301XGFRTL7	-	D5	8	9	24.0	073
	2.5	2.5	2.8	-	0.17	-	0	6.5	6.5	-10	140	Ruby	301XGFRTL7	-	LA	9	9	24.0	073
	2.5	2.5	2.8	-	0.17	-	0	6.5	6.5	-10	140	Ruby	301XGFRTL7	-	LB-LC	13	16	24.0	073
	2.5	2.5	2.8	-	0.17	-	0	6.5	-	-10	140	Ruby	301XGFRTL7	-	XS03	9	-	24.0	073
	2.5	2.5	2.8	-	0.17	-	0	6.5	6.5	-10	140	FDA FKM	301XGFVTL7	-	D4	13	16	24.0	073
2.5	2.5	2.8	-	0.17	-	0	6.5	6.5	-10	140	FDA FKM	301XGFVTL7	-	D5	8	9	24.0	073	
2.5	2.5	2.8	-	0.17	-	0	6.5	6.5	-10	140	FDA FKM	301XGFVTL7	-	LA	9	9	24.0	073	
2.5	2.5	2.8	-	0.17	-	0	6.5	6.5	-10	140	FDA FKM	301XGFVTL7	-	LB-LC	13	16	24.0	073	



Dans cette page	Raccord	Orifice (mm)	Kv (l/min)	Pression Diff. Max. (bar)	Temp. Fluide (°C)	Temp. Amb. (°C)
de	SB	2	2.2	6.5	-10	-10
à	SB	2.5	2.8	10	140	50



Schéma 072



Schéma 073

3/2

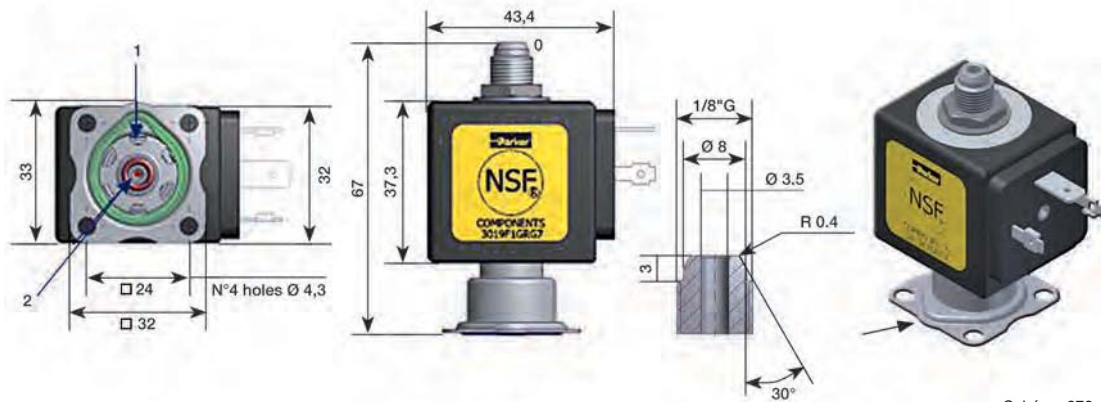
ELECTROVANNES POUR DISTRIBUTION DE BOISSONS - LIQUIPURE® COMMANDE DIRECTE

INOX

MONTAGE SUR EMBASE

FERMÉE HORS TENSION

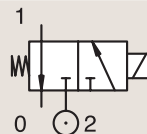

Raccord	Orifice Ø		Facteur d'Ecoulement			Pression Différentielle			Temp. Fluide		Joint	Electrovannes PARKER			Puissance		Groupe Electrique	N° Schéma	
	1	(2)	1	(2)	1	(2)	Min	Max	Min	Max		Ref. Valve	Ref. Boîtier	Ref. Bobine	AC W	DC W			
	mm		Kv l/min		KV l/min		bar	AC bar	DC bar	°C	°C								
SB	2.5	2.5	2.8	-	0.17	-	0	6.5	-	-10	140	FDA FKM	301XGFVTL7	-	XS03	9	-	24.0	073
	3	2.5	3.3	-	0.2	-	0	4	4	-10	140	Ruby	3019F1NRG7	-	D4	13	16	24.0	072
	3	2.5	3.3	-	0.2	-	0	4	4	-10	140	Ruby	3019F1NRG7	-	D5	8	9	24.0	072
	3	2.5	3.3	-	0.2	-	0	4	4	-10	140	Ruby	3019F1NRG7	-	LA	9	9	24.0	072
	3	2.5	3.3	-	0.2	-	0	4	4	-10	140	Ruby	3019F1NRG7	-	LB-LC	13	16	24.0	072
	3	2.5	3.3	-	0.2	-	0	4	-	-10	140	Ruby	3019F1NRG7	-	XS03	9	-	24.0	072
	3	2.5	3.3	-	0.2	-	0	4	4	-10	140	FDA FKM	3019F1NVG7	-	D4	13	16	24.0	072
	3	2.5	3.3	-	0.2	-	0	4	4	-10	140	FDA FKM	3019F1NVG7	-	D5	8	9	24.0	072
	3	2.5	3.3	-	0.2	-	0	4	4	-10	140	FDA FKM	3019F1NVG7	-	LA	9	9	24.0	072
	3	2.5	3.3	-	0.2	-	0	4	4	-10	140	FDA FKM	3019F1NVG7	-	LB-LC	13	16	24.0	072
	3	2.5	3.3	-	0.2	-	0	4	-	-10	140	FDA FKM	3019F1NVG7	-	XS03	9	-	24.0	072
	3	2.5	4.2	-	0.25	-	0	4	4	-10	140	Ruby	301XGFRTN7	-	D4	13	16	24.0	073
	3	2.5	4.2	-	0.25	-	0	4	4	-10	140	Ruby	301XGFRTN7	-	D5	8	9	24.0	073
	3	2.5	4.2	-	0.25	-	0	4	4	-10	140	Ruby	301XGFRTN7	-	LA	9	9	24.0	073
	3	2.5	4.2	-	0.25	-	0	4	4	-10	140	Ruby	301XGFRTN7	-	LB-LC	13	16	24.0	073
	3	2.5	4.2	-	0.25	-	0	4	-	-10	140	Ruby	301XGFRTN7	-	XS03	9	-	24.0	073
	3	2.5	4.2	-	0.25	-	0	4	4	-10	140	FDA FKM	301XGFVTN7	-	D4	13	16	24.0	073
	3	2.5	4.2	-	0.25	-	0	4	4	-10	140	FDA FKM	301XGFVTN7	-	D5	8	9	24.0	073
	3	2.5	4.2	-	0.25	-	0	4	4	-10	140	FDA FKM	301XGFVTN7	-	LA	9	9	24.0	073
	3	2.5	4.2	-	0.25	-	0	4	4	-10	140	FDA FKM	301XGFVTN7	-	LB-LC	13	16	24.0	073
3	2.5	4.2	-	0.25	-	0	4	-	-10	140	FDA FKM	301XGFVTN7	-	XS03	9	-	24.0	073	



Dans cette page	Raccord	Orifice (mm)	Kv (l/min)	Pression Diff. Max. (bar)	Temp. Fluide (°C)	Temp. Amb. (°C)
de	SB	2.5	2.8	4	-10	-10
à	SB	3	4.2	6.5	140	50



Schéma 073



Schéma 072

ELECTROVANNES 2 ET 3 VOIES POUR APPLICATION TRANSPORT



ELECTROVANNES 2 VOIES POUR APPLICATION TRANSPORT

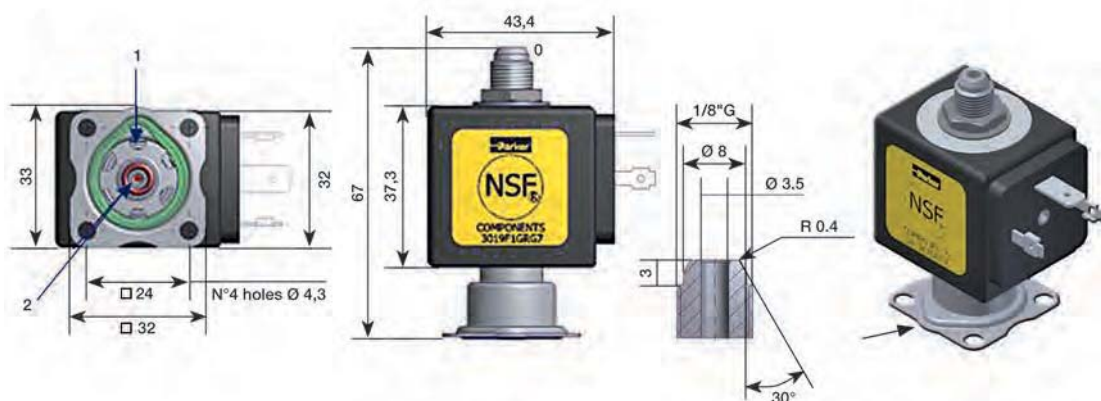

2/2

Commande	Corps de Valve	Fonction	Raccord	Orifice (mm)	Facteur d'Écoulement Kv(l/min)	Pression Différentielle (bar)	Temp. Max. Fluide (°C)	Page Valves Parker	Page Valves Parker LUCIFER®
Servo-commande	Laiton/Raccord rapide	Fermée hors tension	10 mm	11	12	3	90	-	266
	Laiton/Raccord cannelé	Fermée hors tension	10 mm	11	12	3	90	-	266
	Laiton/Raccord tuyau	Fermée hors tension	12.7 mm	11	33	3	90	-	268
			15.9 mm	11	36	3	90	-	268

2/2

ELECTROVANNES 2 VOIES POUR APPLICATION TRANSPORT SERVO-COMMANDE



Transport

LAITON RACCORD RAPIDE

FERMÉE HORS TENSION

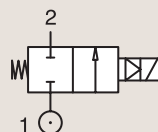

Raccord	Orifice Ø mm	Facteur d'Écoulement			Pression Différentielle			Temp. Fluide		Joint	Electrovannes PARKER LUCIFER®			Voltage		Puissance		Groupe Electrique	N° Schéma
		Kv l/min	KV m³/h	Qn l/min	Min bar	Max AC bar	DC bar	Min °C	Max °C		Ref. Valve	Ref. Boîtier	Ref. Bobine	AC W	DC W				
10 mm	11	12	0.72	-	0.2	-	3	-40	90	EPDM	321K1543	2168	495294	12 VDC	-	9	13.0	8242	
	11	12	0.72	-	0.2	-	3	-40	90	EPDM	321K1543	2169	495294	24 VDC	-	9	13.0	8242	
	11	12	0.72	-	0.2	-	3	-40	90	EPDM	321K1543	2168	496193	12 VDC	-	9	13.0	8242	
	11	12	0.72	-	0.2	-	3	-40	90	EPDM	321K1543	2169	496193	24 VDC	-	9	13.0	8242	

LAITON RACCORD CANNELÉ

FERMÉE HORS TENSION

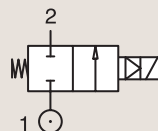

Raccord	Orifice Ø mm	Facteur d'Écoulement			Pression Différentielle			Temp. Fluide		Joint	Electrovannes PARKER LUCIFER®			Voltage		Puissance		Groupe Electrique	N° Schéma
		Kv l/min	KV m³/h	Qn l/min	Min bar	Max AC bar	DC bar	Min °C	Max °C		Ref. Valve	Ref. Boîtier	Ref. Bobine	AC W	DC W				
10 mm	11	12	0.72	-	0.2	-	3	-40	90	EPDM	321K1535	2168	495294	12 VDC	-	9	13.0	8241	
	11	12	0.72	-	0.2	-	3	-40	90	EPDM	321K1535	2169	495294	24 VDC	-	9	13.0	8241	
	11	12	0.72	-	0.2	-	3	-40	90	EPDM	321K1535	2168	496193	12 VDC	-	9	13.0	8241	
	11	12	0.72	-	0.2	-	3	-40	90	EPDM	321K1535	2169	496193	24 VDC	-	9	13.0	8241	



Dans cette page	Raccord	Orifice (mm)	Kv (l/min)	Pression Diff. Max. (bar)	Temp. Fluide (°C)	Temp. Amb. (°C)
de	10 mm	11	12	3	-40	-40
à	10 mm	11	12	3	90	80



Schéma 8242



Schéma 8241

2/2

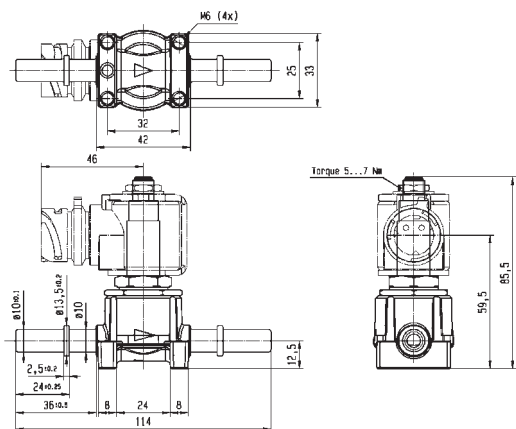
ELECTROVANNES 2 VOIES POUR APPLICATION TRANSPORT SERVO-COMMANDE

LAITON

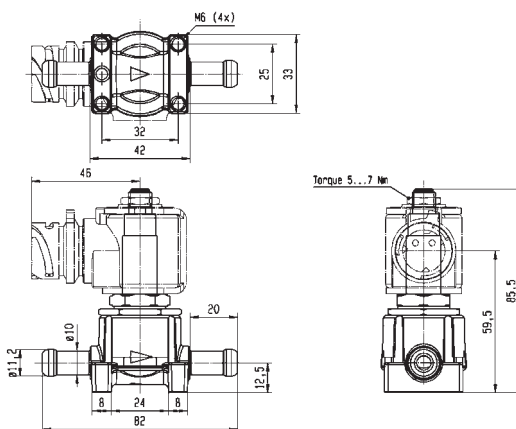
RACCORD TUYAU

FERMÉE HORS TENSION

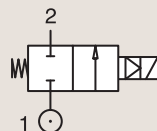

Raccord	Orifice Ø	Facteur d'Écoulement			Pression Différentielle			Temp. Fluide		Joint	Electrovannes PARKER LUCIFER®			Voltage		Puissance		Groupe Electrique	N° Schéma
					Min	Max		Min	Max		Ref. Valve	Ref. Boîtier	Ref. Bobine	AC W	DC W				
		bar	AC bar	DC bar	°C	°C													
1/2" BSP	11	36	2.16	-	0.2	-	3	-40	90	EPDM	321K1523	2168	495294	12 VDC	-	9	13.0	8238	
	11	36	2.16	-	0.2	-	3	-40	90	EPDM	321K1523	2169	495294	24 VDC	-	9	13.0	8238	
	11	36	2.16	-	0.2	-	3	-40	90	EPDM	321K1523	2168	496193	12 VDC	-	9	13.0	8238	
	11	36	2.16	-	0.2	-	3	-40	90	EPDM	321K1523	2169	496193	24 VDC	-	9	13.0	8238	
12.7 mm	11	33	1.98	-	0.2	-	3	-40	90	EPDM	321K1536	2168	495294	12 VDC	-	9	13.0	8282	
	11	33	1.98	-	0.2	-	3	-40	90	EPDM	321K1536	2169	495294	24 VDC	-	9	13.0	8282	
	11	33	1.98	-	0.2	-	3	-40	90	EPDM	321K1536	2168	496193	12 VDC	-	9	13.0	8282	
	11	33	1.98	-	0.2	-	3	-40	90	EPDM	321K1536	2169	496193	24 VDC	-	9	13.0	8282	
15.9 mm	11	36	2.16	-	0.2	-	3	-40	90	EPDM	321K1537	2168	495294	12 VDC	-	9	13.0	8281	
	11	36	2.16	-	0.2	-	3	-40	90	EPDM	321K1537	2169	495294	24 VDC	-	9	13.0	8281	
	11	36	2.16	-	0.2	-	3	-40	90	EPDM	321K1537	2168	496193	12 VDC	-	9	13.0	8281	
	11	36	2.16	-	0.2	-	3	-40	90	EPDM	321K1537	2169	496193	24 VDC	-	9	13.0	8281	



Dans cette page	Raccord	Orifice (mm)	Kv (l/min)	Pression Diff. Max. (bar)	Temp. Fluide (°C)	Temp. Amb. (°C)
de	1/2"	11	33	3	-40	-40
à	15.9 mm	11	36	3	90	80



Schéma 8238



Schéma 8282

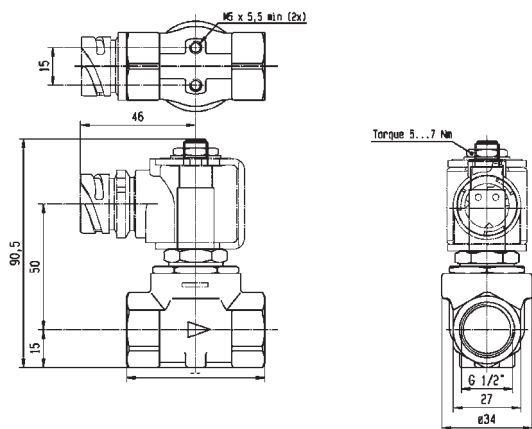

Schéma 8281

ELECTROVANNES 2 ET 3 VOIES POUR APPLICATION TRANSPORT

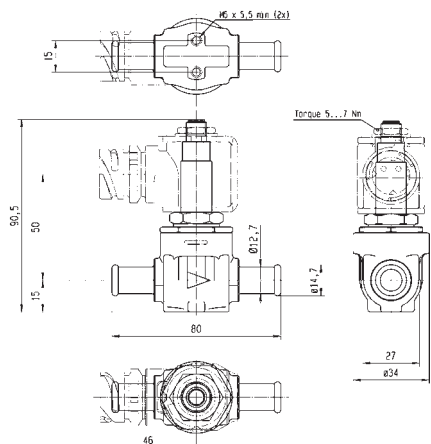
ELECTROVANNES 2 ET 3 VOIES POUR APPLICATION TRANSPORT

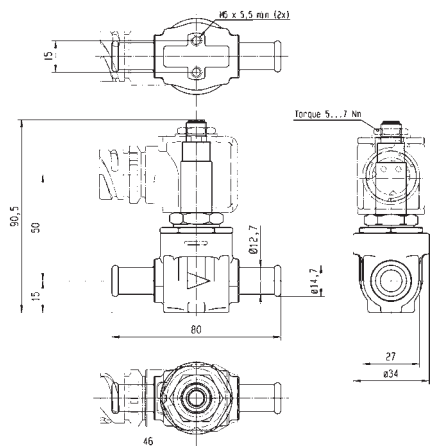

ELECTROVANNES PWM (MODULATION DE LARGEUR D'IMPULSION)



3/2

Commande	Corps de Valve	Fonction	Raccord	Orifice (mm)	Facteur d'Écoulement Qn (l/min)	Pression Différentielle (bar)	Temp. Max. Fluide (°C)	Page Valves Parker	Page Valves Parker LUCIFER®
Commande Directe	Laiton/Raccord rapide	Fermée hors tension	1/8"	1.8	110	8	80	-	272

3/2

ELECTROVANNES 3 VOIES POUR APPLICATION TRANSPORT COMMANDE DIRECTE - FONCTIONNEMENT PWM



Transport

LAITON
RACCORD RAPIDE

FERMÉE HORS TENSION

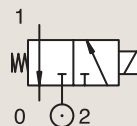

Raccord	Orifice Ø		Facteur d'Écoulement Qn l/min	Pression Différentielle			Temp. Fluide		Joint	Electrovannes PARKER LUCIFER®			Puissance		Groupe Electrique	N° Schéma
	1	(2)		Min	Max		Min	Max		Ref. Valve	Ref. Boîtier	Ref. Bobine	AC W	DC W		
					AC bar	DC bar										
BSP	mm			bar	bar	bar	°C	°C								
1/8"	1.8	1.5	110	0	-	8	-30	80	TPE/PVDF	131K0648 ₁₂₃	2161	495294	-	9	13.0	7872
	1.8	1.5	110	0	-	8	-30	80	TPE/PVDF	131K0648 ₁₂₃	2161	496193	-	9	13.0	7872

Notes:

1. Plage de fréquence: 5 to 20 Hz max
2. Durée de vie : 80 millions de cycles max.
3. Valve disponible également avec raccords métriques



Dans cette page	Raccord	Orifice (mm)	Qn (l/min)	Pression Diff. Max. (bar)	Temp. Fluide (°C)	Temp. Amb. (°C)
de	1/8"	1.8	110	8	-30	-30
à	1/8"	1.8	110	8	80	85



Schéma 7872

DISTRIBUTEURS 5 VOIES POUR COMMANDE D'ACTIONNEURS PNEUMATIQUES

DISTRIBUTEURS 5 VOIES POUR COMMANDE D'ACTIONNEURS PNEUMATIQUES

DISTRIBUTEURS 5 VOIES POUR COMMANDE D'ACTIONNEURS PNEUMATIQUES (RACCORD TUYAU/MONTAGE SUR EMBASE)

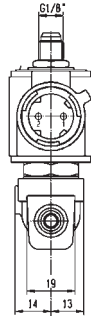
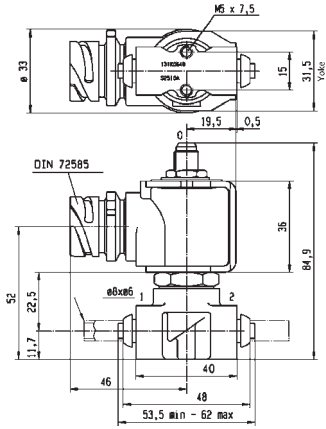

5/2

Commande	Corps de Valve	Fonction	Raccord	Orifice (mm)	Facteur d'Écoulement Qn(l/min)	Pression Différentielle (bar)	Temp. Max. Fluide (°C)	Page Valves Parker	Page Valves Parker LUCIFER®
Servo-commande	Aluminium anodisé/ Raccord tuyau	Fermée hors tension	1/8"-1/4"	6	630	10	75	-	276
			1/4"	6 à 14	2500	40	75	-	276
			1/2"	14	2500	15	75	-	278
	Aluminium anodisé/ Raccord tuyau/Clapet	Fermée hors tension	1/8"-1/4"	6	630	10	75	-	280
			1/4"	8 à 14	2500	15	75	-	280
			1/8"	4	400	10	75	-	282
	Aluminium anodisé/ Montage sur embase	Double Bobines	1/8"	4	315	10	75	-	282
		Fermée hors tension	1/8"	6	630	10	75	-	284
	Aluminium anodisé/ Montage sur embase/ Clapet	Controlée par Impulsion Electrique	1/8"	6	630	10	75	-	284
			Fermée hors tension	-	15	5000	10	75	-
		Double Bobines	1/8"	15	5000	10	75	-	286
			4 mm	4	400	10	75	-	286
			4 mm	4	315	10	75	-	288
	Controlée par Impulsion Electrique	-	15	5000	10	75	-	288	
Aluminium anodisé/ CETOP/Clapet	Double Bobines	1/8"	6	800	10	75	-	288	
Alliage de Zinc / Raccord tuyau/Clapet	Fermée hors tension	1/4"	8	1400	10	75	-	290	
	Double Bobines	1/4"	8	1400	10	100	-	292	
POM/CETOP/Poppet	Fermée hors tension	-	6 à 8	800	10	75	-	292	
		1/8"	6	800	10	75	-	294	
	Controlée par Impulsion Electrique	1/8"	6	800	10	75	-	296	
Pilotage externe	Aluminium anodisé/ Montage sur embase	Fermée hors tension	1/8"	7	800	10	75	-	298

5/2

DISTRIBUTEURS 5 VOIES POUR COMMANDE D'ACTIONNEURS
PNEUMATIQUES (RACCORD TUYAU/MONTAGE SUR EMBASE)
SERVO-COMMANDE



Process



Equipement Industriel

ALUMINIUM ANODISÉ RACCORD TUYAU

FERMÉE HORS TENSION

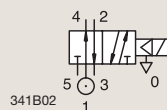
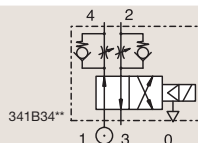

Raccord BSP	Orifice Ø 1 mm	Facteur d'Écoulement Qn l/min	Pression Différentielle			Temp. Fluide		Joint	Electrovannes Parker LUCIFER®			IS		Puissance		Groupe Electrique	N° Schéma
			Min bar	Max AC bar	Max DC bar	Min °C	Max °C		Ref. Valve	Ref. Boîtier	Ref. Bobine	AC W	DC W				
1/8"- 1/4"	6	630	1	10	10	-10	75	FKM	341B34 ₁	4270	481000	8	8	2.0	3286		
	6	630	1	10	10	-10	75	FKM	341B34 ₁	2995	481865	8	9	2.0	3286		
	6	630	1	10	10	-10	75	FKM	341B34 ₁	4270	486265	14	14	2.0	3286		
	6	630	1	10	10	-10	75	FKM	341B3403	4270	481000	8	8	2.1	3286		
	6	630	1	10	10	-10	75	FKM	341B3403	2995	481865	8	9	2.1	3286		
	6	560	1	-	10	-10	55	NBR	341B3490	2995	483580.01	*	-	0.5 to 3	7.0/8.0	3561	
	6	560	1	-	10	-10	75	NBR	341B3490	-	488660.01	*	-	0.3 to 3	7.0/8.0	3561	
1/4"	6	630	1	10	10	-25	75	PUR	341B3440	4270	481000	8	8	2.1	3286		
	6	630	1	10	10	-25	75	PUR	341B3440	2995	481865	8	9	2.1	3286		
	8	640	1	40	40	-10	75	NBR	341B02 ₂	4270	481000	8	8	2.1	8115		
	8	640	1	40	40	-10	75	NBR	341B02 ₂	2995	481865	8	9	2.1	8115		

Notes:

1. Avec régulateur de débit
2. Valve avec conduite de retour du pilote intégrée



Dans cette page	Raccord	Orifice (mm)	Qn (l/min)	Pression Diff. Max. (bar)	Temp. Fluide (°C)	Temp. Amb. (°C)
de	1/8"-1/4"	6	560	10	-25	-25
à	1/4"	8	640	40	75	50



Schéma 3286



Schéma 3561

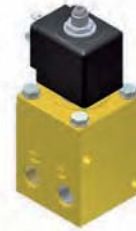
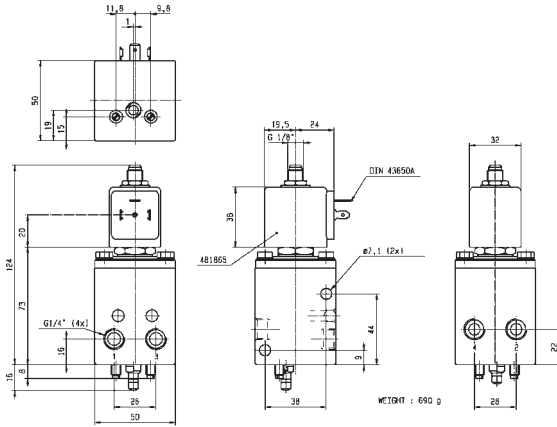

Schéma 8115

5/2

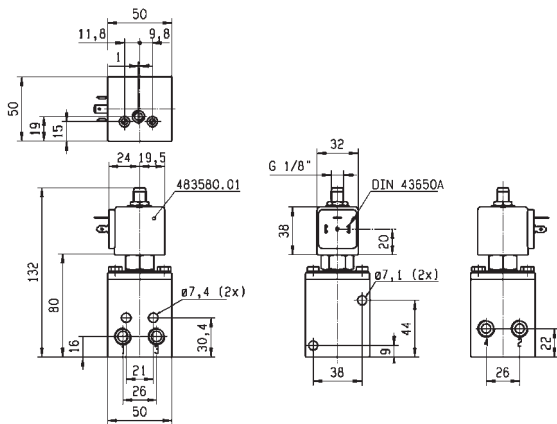
DISTRIBUTEURS 5 VOIES POUR COMMANDE D'ACTIONNEURS
PNEUMATIQUES (RACCORD TUYAU/MONTAGE SUR EMBASE)
SERVO-COMMANDE

ALUMINIUM ANODISÉ
RACCORD TUYAU

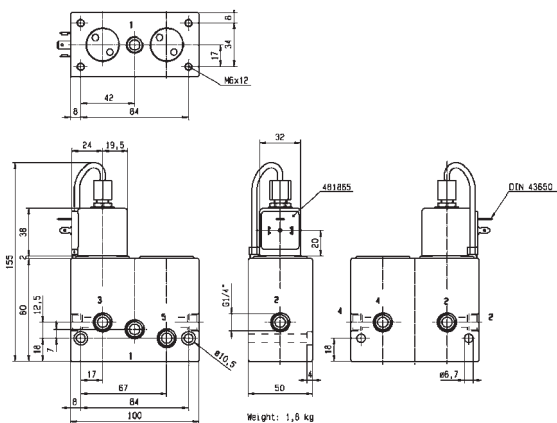
FERMÉE HORS TENSION

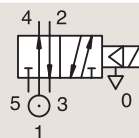

Raccord	Orifice Ø 1	Facteur d'Écoulement Qn l/min	Pression Différentielle			Temp. Fluide		Joint	Electrovannes Parker LUCIFER®			Puissance		Groupe Électrique	N° Schéma
			Min bar	Max AC bar	Max DC bar	Min °C	Max °C		Ref. Valve	Ref. Boîtier	Ref. Bobine	AC W	DC W		
1/4"	8	1000	1	15	15	-10	75	NBR	E341B01	2995	481865	8	9	2.1	3309
	8	1000	1	15	15	-10	75	NBR	E341B01	4270	485100	8	8	2.1	3309
	14	2500	2	15	15	-10	75	NBR	E341F21	4270	481000	8	8	2.1	3310
1/2"	14	2500	1	15	15	-10	75	NBR	E341B21 ₁	2995	481865	8	9	2.1	3315
	14	2500	1	15	15	-10	75	NBR	E341B21 ₁	-	483371	8	8	2.1	3315

Notes:

1.Valve uniquement compatible avec air et gaz neutres



Dans cette page	Raccord	Orifice (mm)	Qn (l/min)	Pression Diff. Max. (bar)	Temp. Fluide (°C)	Temp. Amb. (°C)
de	1/4"	8	1000	15	-10	-10
à	1/2"	14	2500	15	75	50



Schéma 3309



Schéma 3310

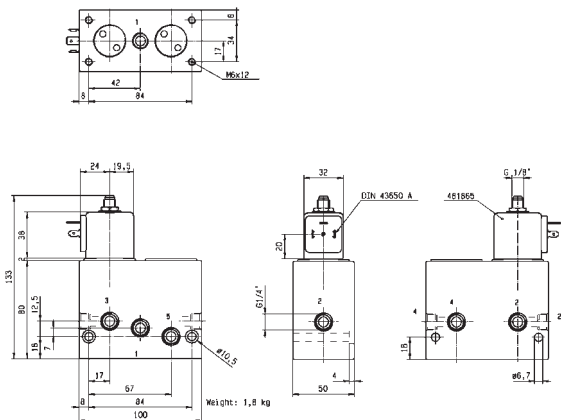

Schéma 3315

5/2

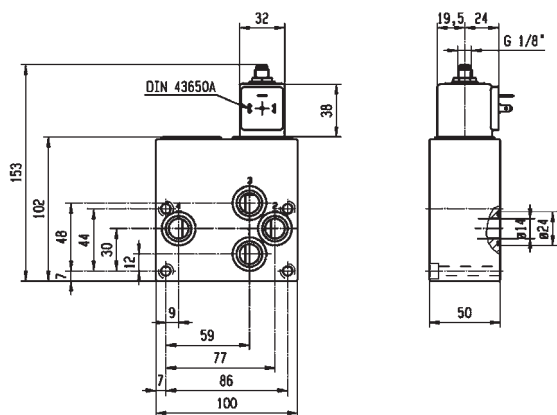
DISTRIBUTEURS 5 VOIES POUR COMMANDE D'ACTIONNEURS
PNEUMATIQUES (RACCORD TUYAU/MONTAGE SUR EMBASE)
SERVO-COMMANDE

ALUMINIUM ANODISÉ
RACCORD TUYAU

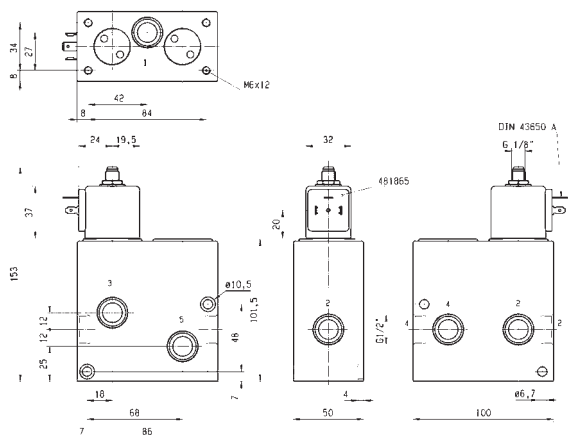
COMMANDE PAR IMPULSION

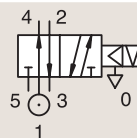

Raccord	Orifice Ø 1	Facteur d'Écoulement Qn l/min	Pression Différentielle			Temp. Fluide		Joint	Electrovannes Parker LUCIFER®			Puissance		Groupe Electrique	N° Schéma
			Min bar	Max AC bar	DC bar	Min °C	Max °C		Ref. Valve	Ref. Boîtier	Ref. Bobine	AC W	DC W		
1/8"- 1/4"	6	630	1	10	-	-10	75	NBR	345B34 ₁₂	4269	484990	11	-	4.0	3286
	6	630	1	-	10	-10	75	NBR	345B34 ₁₂	4269	485400	-	13	4.0	3286
1/4"	8	1000	1	15	-	-10	75	NBR	345B04	4269	484990	11	-	4.0	3309
	8	1000	1	-	15	-10	75	NBR	345B04	4269	485400	-	13	4.0	3309
	14	2500	1	15	-	-10	75	NBR	345B24	4269	484990	11	-	4.0	3315
	14	2500	1	-	15	-10	75	NBR	345B24	4269	485400	-	13	4.0	3315

Notes:

1. Avec régulateur de débit

2. Valve uniquement compatible avec air et gaz neutres



Dans cette page	Raccord	Orifice (mm)	Qn (l/min)	Pression Diff. Max. (bar)	Temp. Fluide (°C)	Temp. Amb. (°C)
de	1/8"-1/4"	6	630	10	-10	-10
à	1/4"	14	2500	15	75	50



Schéma 3286



Schéma 3309

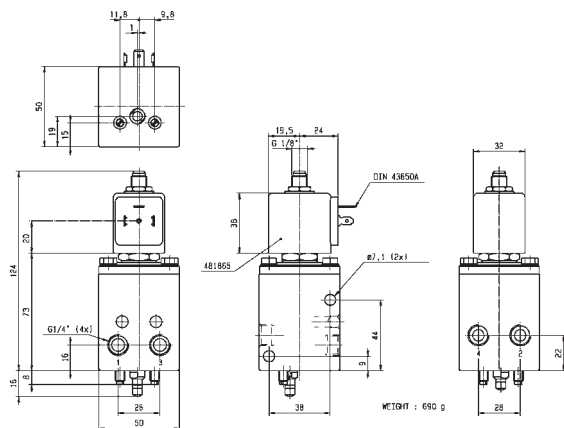

Schéma 3315

5/2

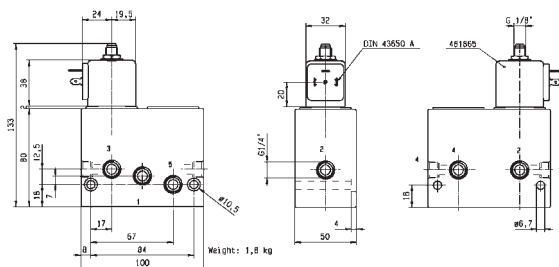
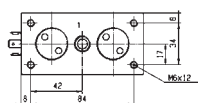
DISTRIBUTEURS 5 VOIES POUR COMMANDE D'ACTIONNEURS
PNEUMATIQUES (RACCORD TUYAU/MONTAGE SUR EMBASE)
SERVO-COMMANDE

ALUMINIUM ANODISÉ
RACCORD TUYAU

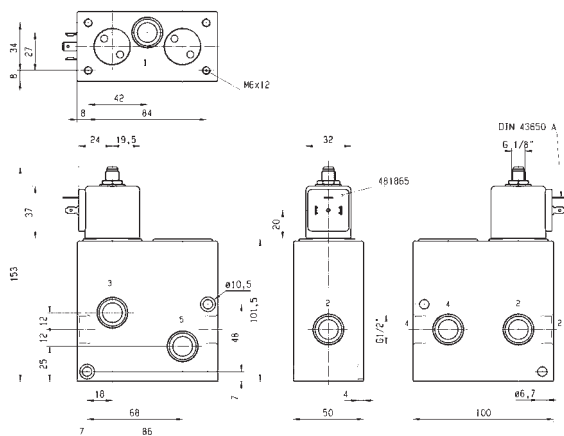
FERMÉE HORS TENSION

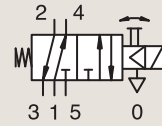

Raccord	Orifice Ø	Facteur d'Écoulement	Pression Différentielle			Temp. Fluide		Joint	Electrovannes Parker LUCIFER®			Puissance		Groupe Electrique	N° Schéma
			Min	Max	DC bar	Min	Max		Ref. Valve	Ref. Boîtier	Ref. Bobine	AC W	DC W		
BSP	1 mm	Qn l/min	bar	AC bar	DC bar	°C	°C								
1/8"	4	400	1	10	10	-10	75	NBR	341L9101	-	482605	4	5	1.1	3894
	4	400	1	10	10	-10	75	NBR	341L9101	-	482606	2	2.5	1.1	3894
	4	400	1	10	10	-10	75	NBR	341L9101	8993	488980	2	2.5	1.1	3894
	4	400	1	10	10	-10	75	NBR	341L9101	8993	495865	2	2.5	1.1	3894

ALUMINIUM ANODISÉ
RACCORD TUYAU

COMMANDE PAR 2 SOLÉNOIDES

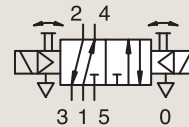

Raccord	Orifice Ø	Facteur d'Écoulement	Pression Différentielle Max.			Temp. Fluide		Joint	Electrovannes Parker LUCIFER®			Puissance		Groupe Electrique	N° Schéma
			Min	Max (MOPD)	DC bar	Min	Max		Ref. Valve	Ref. Boîtier	Ref. Bobine	AC W	DC W		
BSP	1 mm	Qn l/min	bar	AC bar	DC bar	°C	°C								
1/8"	4	315	2	10	10	-10	75	NBR	347L9101	-	482605	4	5	1.1	3896
	4	315	2	10	10	-10	75	NBR	347L9101	-	482606	2	2.5	1.1	3896
	4	315	2	10	10	-10	75	NBR	347L9101	8993	488980	2	2.5	1.1	3896
	4	315	2	10	10	-10	75	NBR	347L9101	8993	495865	2	2.5	1.1	3896



Dans cette page	Raccord	Orifice (mm)	Qn (l/min)	Pression Diff. Max. (bar)	Temp. Fluide (°C)	Temp. Amb. (°C)
de	1/8"	4	315	10	-10	-10
à	1/8"	4	400	10	75	50



Schéma 3894



Schéma 3896

5/2

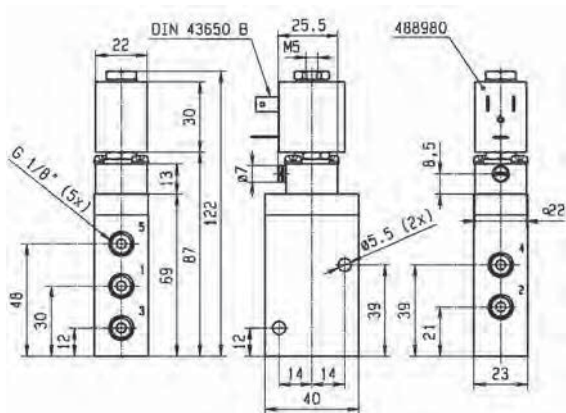
DISTRIBUTEURS 5 VOIES POUR COMMANDE D'ACTIONNEURS
PNEUMATIQUES (RACCORD TUYAU/MONTAGE SUR EMBASE)
SERVO-COMMANDE

ALUMINIUM ANODISÉ MONTAGE SUR EMBASE

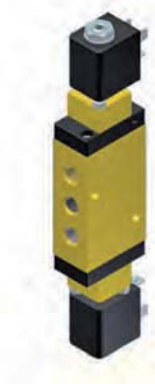
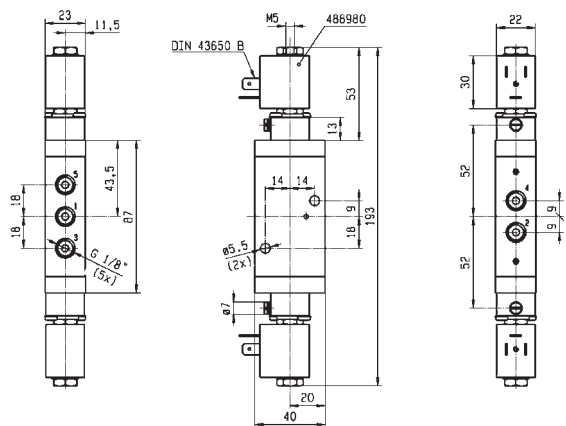
FERMÉE HORS TENSION

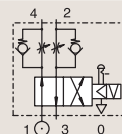

Raccord	Orifice Ø 1 mm	Facteur d'Écoulement Qn l/min	Pression Différentielle			Temp. Fluide		Joint	Electrovannes Parker LUCIFER®			Puissance		Groupe Electrique	N° Schéma
			Min bar	Max		Min °C	Max °C		Ref. Valve	Ref. Boîtier	Ref. Bobine	AC W	DC W		
				AC bar	DC bar										
SB	6	630	1	10	10	-10	75	FKM	341F34 ₁	2995	481865	8	9	2.1	3287
	6	630	1	10	10	-10	75	FKM	341F34 ₁	4270	481000	8	8	2.1	3287
	6	630	1	10	10	-10	75	FKM	341F3403	2995	481865	8	9	2.1	3287
	6	630	1	10	10	-10	75	FKM	341F3403	4270	481000	8	8	2.1	3287
	6	630	1	10	10	-25	75	NBR	341F3440	2995	481865	8	9	2.1	3287

Notes:

1.Avec régulateur de débit

ALUMINIUM ANODISÉ MONTAGE SUR EMBASE

COMMANDE PAR IMPULSION

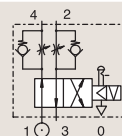

Raccord	Orifice Ø 1 mm	Facteur d'Écoulement Qn l/min	Pression Différentielle			Temp. Fluide		Joint	Electrovannes Parker LUCIFER®			Puissance		Groupe Electrique	N° Schéma
			Min bar	Max		Min °C	Max °C		Ref. Valve	Ref. Boîtier	Ref. Bobine	AC W	DC W		
				AC bar	DC bar										
SB	6	630	1	10	-	-10	75	FKM	345F34 ₁	4269	484990	11	-	4.0	3287
	6	630	1	-	10	-10	75	FKM	345F34 ₁	4269	485400	-	13	4.0	3287

Notes:

1.Avec régulateur de débit



Dans cette page	Raccord	Orifice (mm)	Qn (l/min)	Pression Diff. Max. (bar)	Temp. Fluide (°C)	Temp. Amb. (°C)
de	SB	6	630	10	-25	-25
à	SB	6	630	10	75	50



Schéma 3287

5/2

DISTRIBUTEURS 5 VOIES POUR COMMANDE D'ACTIONNEURS
PNEUMATIQUES (RACCORD TUYAU/MONTAGE SUR EMBASE)
SERVO-COMMANDE

ALUMINIUM ANODISÉ
MONTAGE SUR EMBASE

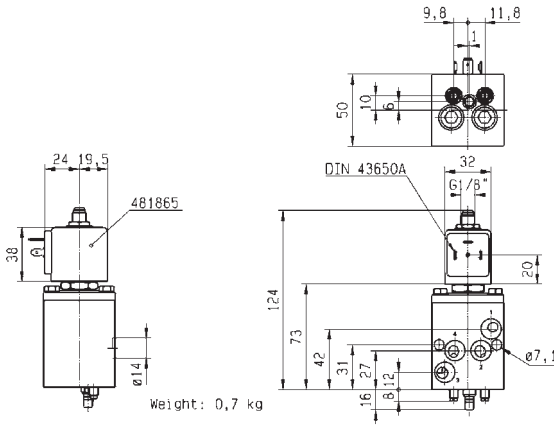
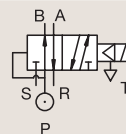

FERMÉE HORS TENSION

Raccord	Orifice Ø 1 mm	Facteur d'Écoulement Qn l/min	Pression Différentielle			Temp. Fluide		Joint	Electrovannes Parker LUCIFER®			IS	Puissance		Groupe Électrique	N° Schéma
			Min bar	Max		Min °C	Max °C		Ref. Valve	Ref. Boîtier	Ref. Bobine		AC W	DC W		
				AC bar	DC bar											
SB	4	400	1	-	10	-10	75	NBR	341L9201 ₁	-	482605	-	5	1.1	3895	
	4	400	1	10	10	-10	75	NBR	341L9201 ₁	-	482606	2	2.5	1.1	3895	
	4	400	1	10	10	-10	75	NBR	341L9201 ₁	8993	488980	2	2.5	1.1	3895	
	4	400	1	10	10	-10	75	NBR	341L9201 ₁	8993	495865	2	2.5	1.1	3895	
	15	5000	0.5	10	10	-10	75	FKM	E341L21 ₁	2995	481865	8	9	2.1/3.0	3299	
	15	5000	0.5	10	10	-10	75	FKM	E341L21 ₁	-	495905	8	8	2.1/3.0	3299	
	15	5000	0.5	-	10	-10	55	NBR	341L2190 ₁	2995	483580.01	*	-	0.5 to 3	7.0	8271
	15	5000	0.5	-	10	-10	75	NBR	341L2190 ₁	-	488660.01	*	-	0.3 to 3	7.0	8271
	15	5000	0.5	-	10	-10	75	NBR	341L2190 ₁	-	495910	*	-	0.3 to 3	7.0	8271

Notes:

1. Avec commande manuelle



Dans cette page	Raccord	Orifice (mm)	Qn (l/min)	Pression Diff. Max. (bar)	Temp. Fluide (°C)	Temp. Amb. (°C)
de	SB	4	400	10	-10	-10
à	SB	15	5000	10	75	50



Schéma 3299



Schéma 8271

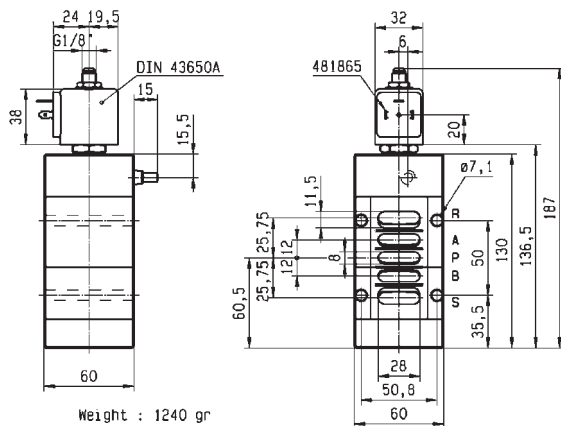

Schéma 3895

5/2

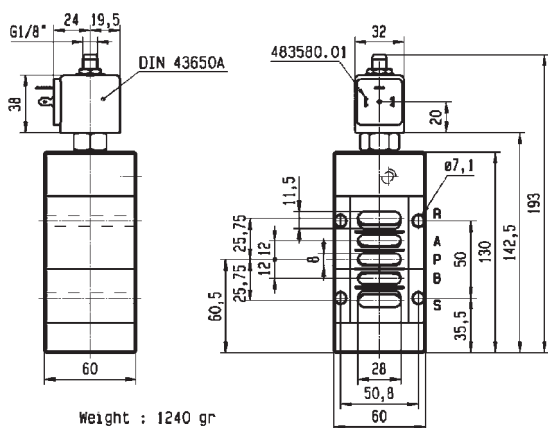
DISTRIBUTEURS 5 VOIES POUR COMMANDE D'ACTIONNEURS
PNEUMATIQUES (RACCORD TUYAU/MONTAGE SUR EMBASE)
SERVO-COMMANDE

ALUMINIUM ANODISÉ
MONTAGE SUR EMBASE

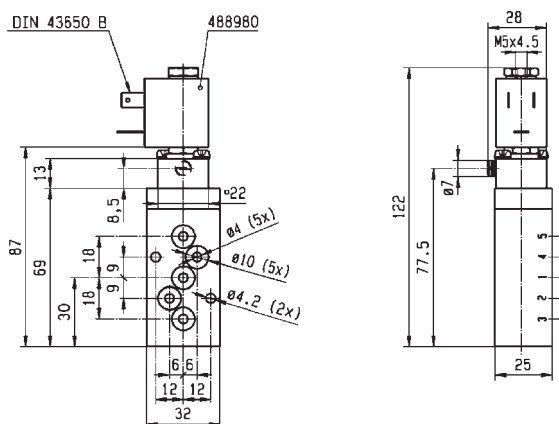
COMMANDE PAR 2 SOLÉNOIDES

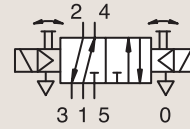

Raccord	Orifice Ø 1 mm	Facteur d'Écoulement Qn l/min	Pression Différentielle			Temp. Fluide		Joint	Electrovannes Parker LUCIFER®			Puissance		Groupe Electrique	N° Schéma
			Min	Max		Min	Max		Ref. Valve	Ref. Boîtier	Ref. Bobine	AC W	DC W		
			bar	AC bar	DC bar	°C	°C								
SB	4	315	2	10	10	-10	75	NBR	347L9201	-	482605	-	5	1.1	3897
	4	315	2	10	10	-10	75	NBR	347L9201	-	482606	2	2.5	1.1	3897
	4	315	2	10	10	-10	75	NBR	347L9201	8993	488980	2	2.5	1.1	3897
	4	315	2	10	10	-10	75	NBR	347L9201	8993	495865	2	2.5	1.1	3897

ALUMINIUM ANODISÉ
MONTAGE SUR EMBASE

COMMANDE PAR IMPULSION

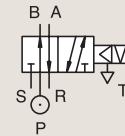

Raccord	Orifice Ø 1 mm	Facteur d'Écoulement Qn l/min	Pression Différentielle			Temp. Fluide		Joint	Electrovannes Parker LUCIFER®			Puissance		Groupe Electrique	N° Schéma
			Min	Max		Min	Max		Ref. Valve	Ref. Boîtier	Ref. Bobine	AC W	DC W		
			bar	AC bar	DC bar	°C	°C								
SB	15	5000	0.5	10	-	-10	75	NBR	345L21	4269	484990	11	-	4.0	3299
	15	5000	0.5	-	10	-10	75	NBR	345L21	4269	485400	-	13	4.0	3299

POM
CETOP

COMMANDE PAR 2 SOLÉNOIDES

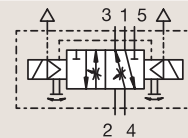

Raccord	Orifice Ø 1 mm	Facteur d'Écoulement Qn l/min	Pression Différentielle			Temp. Fluide		Joint	Electrovannes Parker LUCIFER®			Puissance		Groupe Electrique	N° Schéma
			Min	Max		Min	Max		Ref. Valve	Ref. Boîtier	Ref. Bobine	AC W	DC W		
			bar	AC bar	DC bar	°C	°C								
BSP 1/8"	6	800	1	10	10	-10	75	NBR	347L04	8993	488980	2	2.5	1.1	3694



Dans cette page	Raccord	Orifice (mm)	Qn (l/min)	Pression Diff. Max. (bar)	Temp. Fluide (°C)	Temp. Amb. (°C)
de	SB	4	315	10	-10	-10
à	4 mm	15	5000	10	75	50



Schéma 3897



Weight : 1240 gr

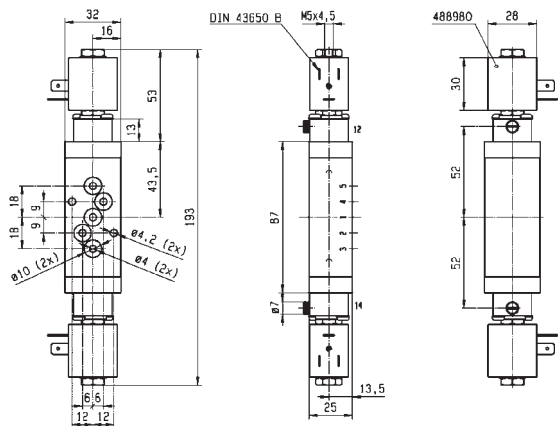
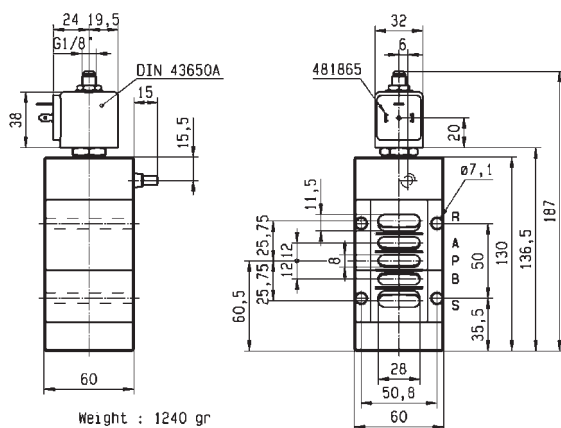

Schéma 3299



Schéma 3694

5/2

DISTRIBUTEURS 5 VOIES POUR COMMANDE D'ACTIONNEURS
PNEUMATIQUES (RACCORD TUYAU/MONTAGE SUR EMBASE)
SERVO-COMMANDE

ALLIAGE DE ZINC
RACCORD TUYAU

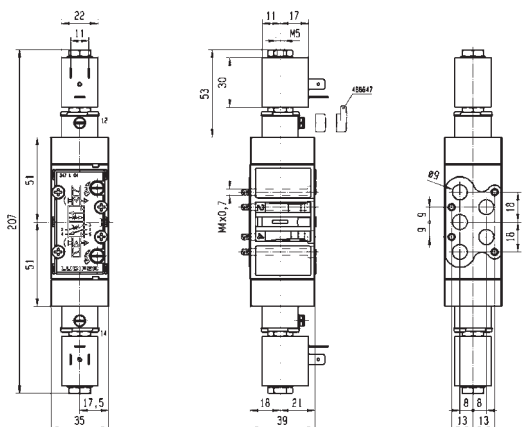
FERMÉE HORS TENSION

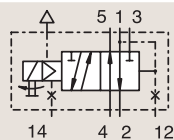

Raccord	Orifice Ø 1	Facteur d'Écoulement Qn l/min	Pression Différentielle			Temp. Fluide		Joint	Electrovannes Parker LUCIFER®			Puissance		Groupe Électrique	N° Schéma
			Min bar	Max AC bar	Max DC bar	Min °C	Max °C		Ref. Valve	Ref. Boîtier	Ref. Bobine	AC W	DC W		
1/4"	8	1400	1	10	10	-10	75	NBR	341L11	-	482605	4	5	1.1	3434
	8	1400	1	10	10	-10	75	NBR	341L11	-	482606	2	2.5	1.1	3434
	8	1400	1	10	10	-10	75	NBR	341L11	8993	488980	2	2.5	1.1	3434
	8	1400	1	10	10	-10	75	NBR	341L11	8993	495865	2	2.5	1.1	3434
	8	1400	1	10	10	-10	75	NBR	E341L1130	2995	481865	8	9	2.1/3.0	3539
	8	1400	1	10	10	-10	75	NBR	E341L1130	-	483371	8	8	2.1/3.0	3539
1/4" NPT	8	1400	1	10	10	-10	75	FKM	U341L1130	2995	481865	8	9	2.1	8297



Dans cette page	Raccord	Orifice (mm)	Qn (l/min)	Pression Diff. Max. (bar)	Temp. Fluide (°C)	Temp. Amb. (°C)
de	1/4"	8	1400	10	-10	-10
à	1/4"	8	1400	10	75	50



Schéma 3434



Schéma 3539

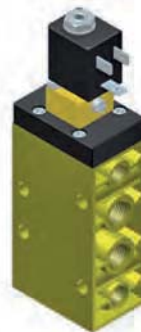
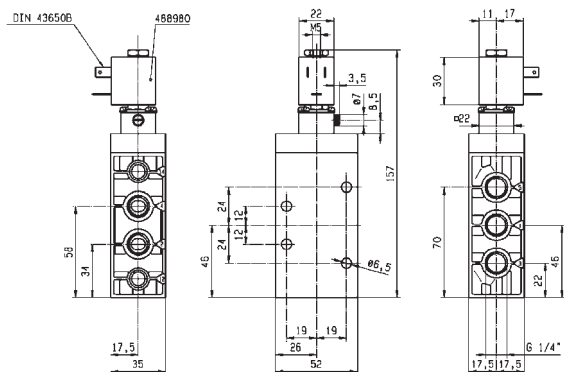

Schéma 8297

5/2

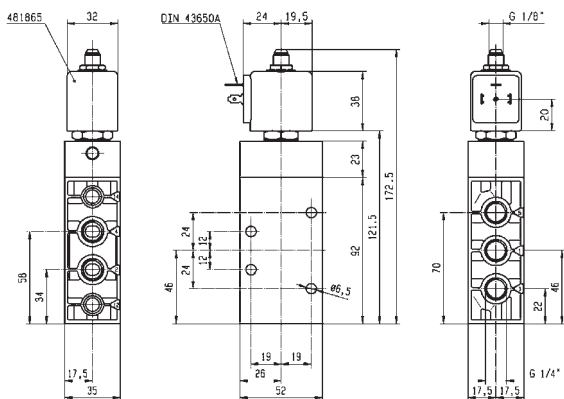
DISTRIBUTEURS 5 VOIES POUR COMMANDE D'ACTIONNEURS
PNEUMATIQUES (RACCORD TUYAU/MONTAGE SUR EMBASE)
SERVO-COMMANDE

ALLIAGE DE ZINC RACCORD TUYAU

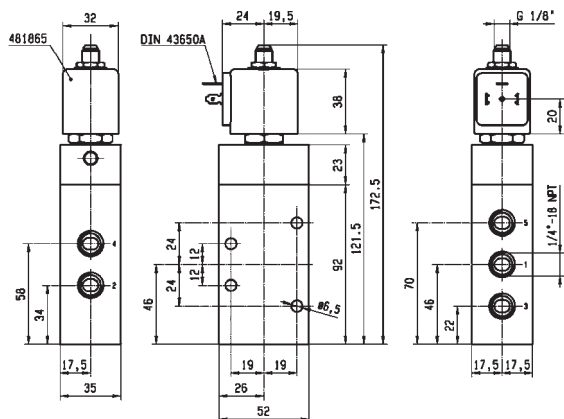
COMMANDE PAR 2 SOLÉNOIDES

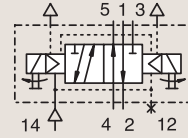

Raccord	Orifice Ø 1	Facteur d'Écoulement Qn l/min	Pression Différentielle			Temp. Fluide		Joint	Electrovannes Parker LUCIFER®			Puissance		Groupe Electrique	N° Schéma
			Min bar	Max AC bar	Max DC bar	Min °C	Max °C		Ref. Valve	Ref. Boîtier	Ref. Bobine	AC W	DC W		
1/4"	8	1400	1	10	10	-10	75	NBR	347L11 ₁	-	482605	4	5	1.1	3461
	8	1400	1	10	10	-10	75	NBR	347L11 ₁	-	482606	2	2.5	1.1	3461
	8	1400	1	10	10	-10	75	NBR	347L11 ₁	8993	488980	2	2.5	1.1	3461
	8	1400	1	10	10	-10	75	NBR	347L11 ₁	8993	495865	2	2.5	1.1	3461
	8	1400	2	10	10	-10	100	FKM	E347L1130 ₁	2995	481865	8	9	2.1/3.0	3541
	8	1400	2	10	10	-10	100	FKM	E347L1130 ₁	4270	481000	8	8	2.1/3.0	3541

Notes:

1.Avec Commande manuelle

POM CETOP

FERMÉE HORS TENSION

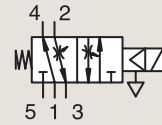

Raccord	Orifice Ø 1	Facteur d'Écoulement Qn l/min	Pression Différentielle			Temp. Fluide		Joint	Electrovannes Parker LUCIFER®			Puissance		Groupe Electrique	N° Schéma
			Min bar	Max AC bar	Max DC bar	Min °C	Max °C		Ref. Valve	Ref. Boîtier	Ref. Bobine	AC W	DC W		
-	6	800	1	10	10	-10	75	FKM	E341L02	2995	481865	8	9	2.1/3.0	3513
-	6	800	1	10	10	-10	75	FKM	E341L02	4270	481000	8	8	2.1/3.0	3513

Notes:

1.Avec Commande manuelle
2.Commande manuelle et régulateur de débit



Dans cette page	Raccord	Orifice (mm)	Qn (l/min)	Pression Diff. Max. (bar)	Temp. Fluide (°C)	Temp. Amb. (°C)
de	1/4"	6	800	10	-10	-10
à	1/4"	8	1400	10	100	50



Schéma 3461



Schéma 3541

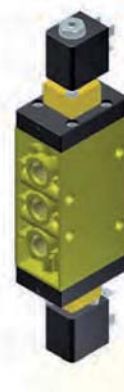
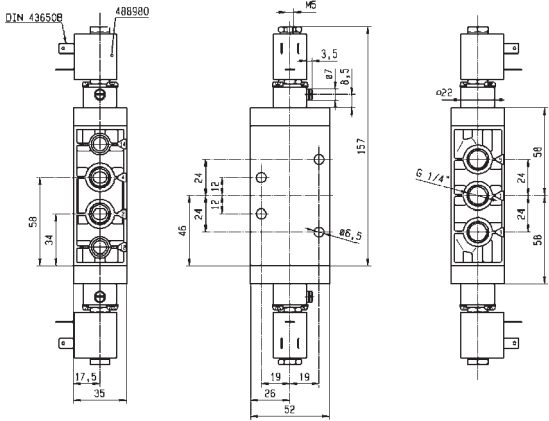

Schéma 3513

5/2

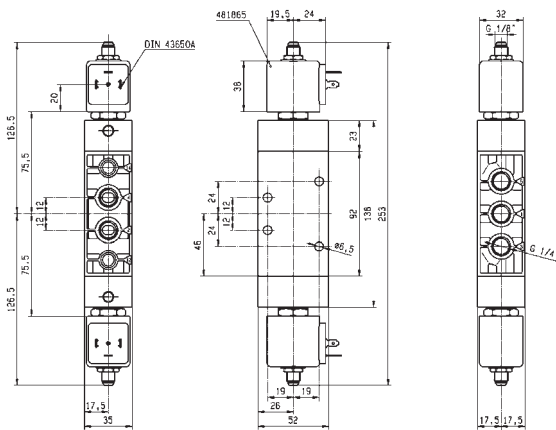
DISTRIBUTEURS 5 VOIES POUR COMMANDE D'ACTIONNEURS
PNEUMATIQUES (RACCORD TUYAU/MONTAGE SUR EMBASE)
SERVO-COMMANDE

POM
CETOP

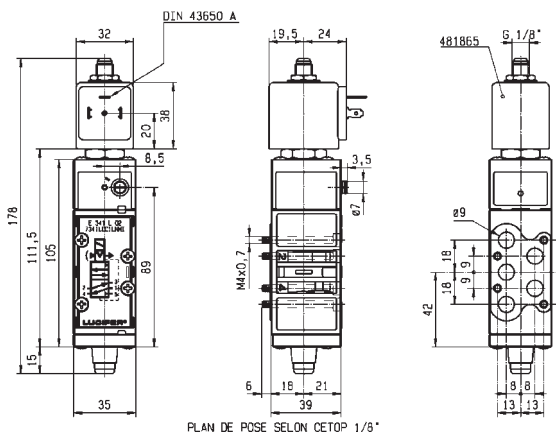
FERMÉE HORS TENSION

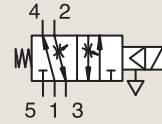

Raccord BSP	Orifice Ø 1 mm	Facteur d'Écoulement Qn l/min	Pression Différentielle			Temp. Fluide		Joint	Electrovannes Parker LUCIFER®			IS		Puissance AC W	DC W	Groupe Electrique	N° Schéma
			Min bar	Max AC bar	Max DC bar	Min °C	Max °C		Ref. Valve	Ref. Boîtier	Ref. Bobine	AC W	DC W				
-	8	800	1	10	10	-10	75	FKM	341L04 ₂	-	482605	4	5	1.1	3437		
	8	800	1	10	10	-10	75	FKM	341L04 ₂	-	482606	2	2.5	1.1	3437		
	8	800	1	10	10	-10	75	FKM	341L04 ₂	8993	488980	2	2.5	1.1	3437		
	8	800	1	10	10	-10	75	FKM	341L04 ₂	8993	495865	2	2.5	1.1	3437		
1/8"	6	800	1	-	10	-10	75	NBR	341L0197	2995	482740	-	1.6	6.0/8.0	8021		
	6	800	1	10	10	-10	75	NBR	341L0197	-	495900	2.5	2	6.0/8.0	8021		
	6	800	1	-	10	-10	75	NBR	341L0197	-	495910	*	0.3 to 3	6.0/8.0	8021		
	6	800	1	-	10	-10	75	NBR	341L0197	2995	496125	-	1.6	6.0/8.0	8021		
	6	800	1	10	10	-10	75	NBR	341L05 ₁	-	482605	4	5	1.1	3430		
	6	800	1	10	10	-10	75	NBR	341L05 ₁	-	482606	2	2.5	1.1	3430		
	6	800	1	10	10	-10	75	NBR	341L05 ₁	8993	488980	2	2.5	1.1	3430		
	6	800	1	10	10	-10	75	NBR	341L05 ₁	8993	495865	2	2.5	1.1	3430		
	6	800	1	10	-	-10	75	FKM	E341L01 ₂	2995	482722	10	-	2.1/3.0	3255		
	6	800	1	10	10	-10	75	FKM	E341L01 ₂	-	483371	8	8	2.1/3.0	3255		
	6	800	1	10	10	-10	75	FKM	E341L01 ₂	2995.33	491514	11	12	2.1/3.0	3255		

Notes:

- 1.Avec Commande manuelle
- 2.Commande manuelle et régulateur de débit



Schéma 3255



Dans cette page	Raccord	Orifice (mm)	Qn (l/min)	Pression Diff. Max. (bar)	Temp. Fluide (°C)	Temp. Amb. (°C)
de	1/8"	6	800	10	-10	-20
à	1/8"	8	800	10	75	50

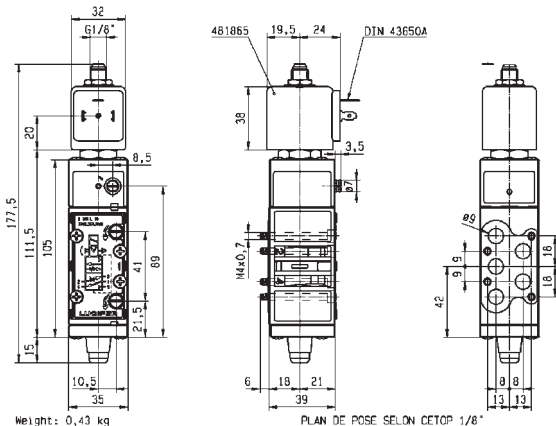
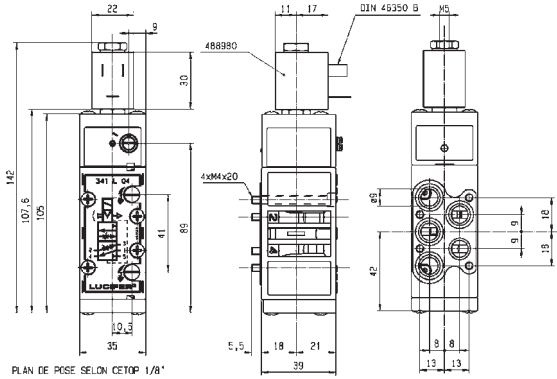

PLAN DE POSE SELON CETOP 1/8"



Schéma 3437



Schéma 8021



PLAN DE POSE SELON CETOP 1/8"

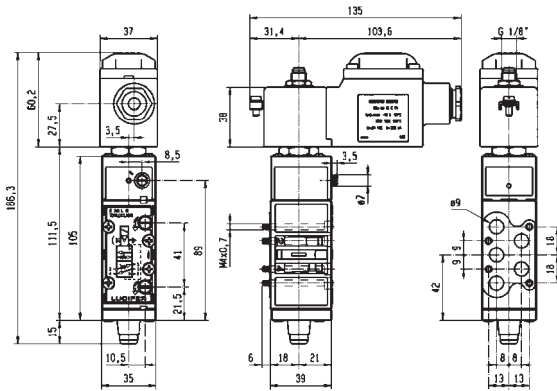
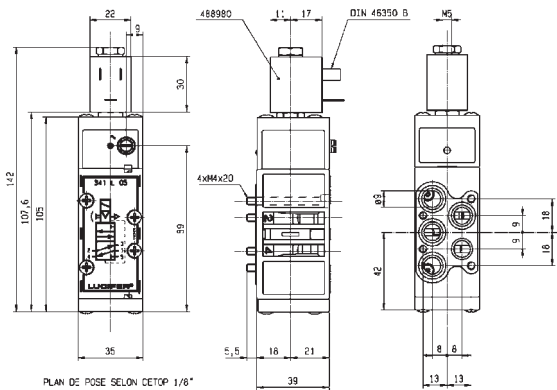

Schéma 3430

5/2

DISTRIBUTEURS 5 VOIES POUR COMMANDE D'ACTIONNEURS
PNEUMATIQUES (RACCORD TUYAU/MONTAGE SUR EMBASE)
SERVO-COMMANDE

POM
CETOP

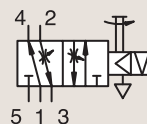

COMMANDE PAR IMPULSION

Raccord	Orifice Ø 1 mm	Facteur d'Écoulement Qn l/min	Pression Différentielle			Temp. Fluide		Joint	Electrovannes Parker LUCIFER®			Puissance		Groupe Electrique	N° Schéma
			Min bar	Max AC bar DC bar		Min °C	Max °C		Ref. Valve	Ref. Boîtier	Ref. Bobine	AC W	DC W		
BSP 1/8"	6	800	1	-	10	-10	75	FKM	345L01 ₁	4269	485400	-	13	4.0	3255

Notes:

1. Commande manuelle et régulateur de débit



Dans cette page	Raccord	Orifice (mm)	Qn (l/min)	Pression Diff. Max. (bar)	Temp. Fluide (°C)	Temp. Amb. (°C)
de	1/8"	6	800	10	-10	-10
à	1/8"	6	800	10	75	50

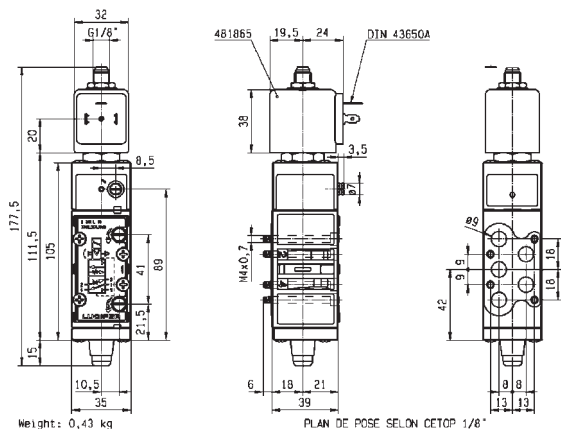

Weight: 0.43 kg

PLAN DE POSE SELON CETOP 1/8"



Schéma 3255

5/2

DISTRIBUTEURS 5 VOIES POUR COMMANDE D'ACTIONNEURS
PNEUMATIQUES (RACCORD TUYAU/MONTAGE SUR EMBASE)
PILOTAGE EXTERNE



Process



Equipement Industriel

ALUMINIUM ANODISÉ
MONTAGE SUR EMBASE

FERMÉE HORS TENSION

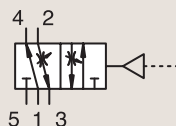

Raccord	Orifice Ø 1 mm	Facteur d'Écoulement Qn l/min 800	Pression Différentielle			Temp. Fluide		Joint	Electrovannes Parker LUCIFER®			Puissance		Groupe Electrique	N° Schéma
			Min bar	Max AC bar	Max DC bar	Min °C	Max °C		Ref. Valve	Ref. Boîtier	Ref. Bobine	AC W	DC W		
SB	7	800	1	10	10	-10	75	FKM/NBR	541L01	-	-	-	-	-	3254



Dans cette page	Raccord	Orifice (mm)	Qn (l/min)	Pression Diff. Max. (bar)	Temp. Fluide (°C)	Temp. Amb. (°C)
de	1/8"	7	800	10	-10	-10
à	1/8"	7	800	10	75	50

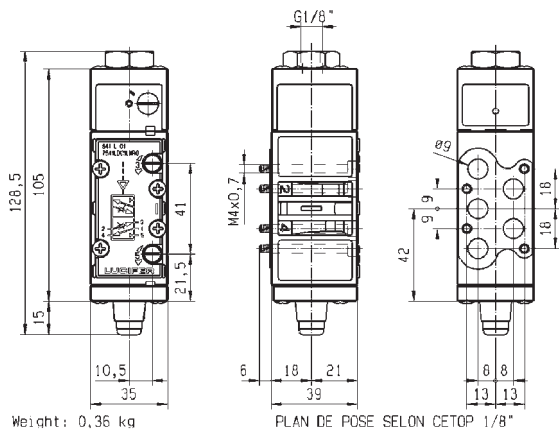

Weight: 0,36 kg

PLAN DE POSE SELON CETOP 1/8"

Schéma 3254

DISTRIBUTEURS 3 & 5 VOIES POUR COMMANDE D'ACTIONNEURS PNEUMATIQUES



DISTRIBUTEURS 3 & 5 VOIES POUR COMMANDE D'ACTIONNEURS PNEUMATIQUES (RACCORD TUYAU)



3/2
5/2

Commande	Corps de Valve	Fonction	Raccord	Orifice (mm)	Qn (l/min)	MOPD (bar)	Temp. Fluide Max. (°C)	Page Valves Parker	Page Valves Parker LUCIFER®
Commande Directe	Laiton/Raccord tuyau	Fermée hors tension	1/8"	1.2 à 1.5	70	10	75	-	302
			1/8"-1/4"	2.5	220	7	75	-	302
			1/4"	1 à 4.5	500	16	120	-	302
		Ouverte hors tension	1/4"	2.5	220	7	75	-	308
		Universelle	1/4"	6	680	10	75	-	308
	Contrôlée par Impulsion Electrique	1/4"	2.5	220	7	100	-	310	
	Laiton/Montage sur embase	Fermée hors tension	5 mm	2.5	180	2	75	-	312
		Universelle	1/8"	2	140	7	120	-	312
Aluminium anodisé/Raccord tuyau	Universelle	1/4"	6	680	10	80	-	314	
Servo-commande	Aluminium anodisé/Raccord tuyau/Tiroir	Fermée hors tension	1/8"	4 à 15	600	10	80	-	316
			1/4"	7 à 8	1400	10	80	-	318
			1/2"	12	3000	10	50	-	322
		Double Bobines	1/8"	4	400	10	80	-	324
			1/4"	7 à 8	1400	10	80	-	326
			1/2"	12	3000	10	50	-	328
		Contrôlée par Impulsion Electrique	1/8"	4	600	10	80	-	328
Réarmement manuel	Laiton/Raccord tuyau	Universelle	1/4"	6	680	10	65	-	330

3/2

DISTRIBUTEURS 3 & 5 VOIES POUR COMMANDE D'ACTIONNEURS PNEUMATIQUES (RACCORD TUYAU) COMMANDE DIRECTE



Equipement Commercial



Equipement Industriel



Process

LAITON RACCORD TUYAU

FERMÉE HORS TENSION

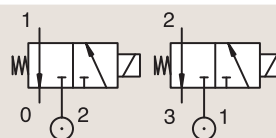

Raccord BSP	Orifice Ø 1 mm	Flow factor Qn l/min	Pression Différentielle			Temp. Fluide		Joint	Electrovannes PARKER LUCIFER®			Zone ATEX	Mode de Protection	Puissance		Groupe Electrique	N° Schéma
			Min bar	Max AC bar DC bar		Min °C	Max °C		Ref. Valve	Ref. Boîtier	Ref. Bobine			AC W	DC W		
1/8"	1.2	50	0	10	10	-10	75	FKM	131M15	8993	488980	-	-	2	2.5	1.1	3382
	1.5	70	0	7	7	-10	75	FKM	131M14	8993	488980	-	-	2	2.5	1.1	3382
1/8"- 1/4"	2.5	220	0	7	7	-40	75	PUR	E131K0358 ₁	2995	481865	-	-	8	9	2.1	3510
	2.5	220	0	7	7	-40	75	PUR	E131K0358 ₁	4270	481000	-	-	8	8	2.1	3510
1/4"	1	36	0	-	10	-10	55	FKM	131K0490	2995	483580.01	0-20	Ex ia IIC T6	-	0.5 to 3	7.0	7058
	1	36	0	-	10	-10	75	FKM	131K0490	-	488660.01	0-20	Ex ia IIC T6	-	0.3 to 3	7.0	7058
	1	36	0	-	10	-10	75	FKM	131K0490	-	495910	0-20	Ex ia IIC T4 to T6	-	0.3 to 3	7.0	7058

Notes:

1.Avec Commande manuelle



Dans cette page	Raccord	Orifice (mm)	Qn (l/min)	Pression Diff. Max. (bar)	Temp. Fluide (°C)	Temp. Amb. (°C)
de	1/8"	1	36	7	-40	-40
à	1/4"	2.5	220	10	75	50



Schéma 3382



Schéma 3510

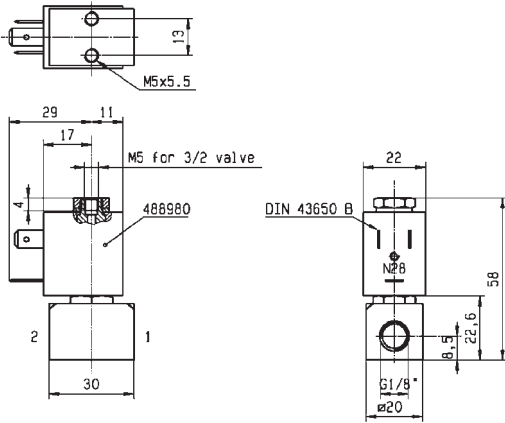

Schéma 7058

3/2

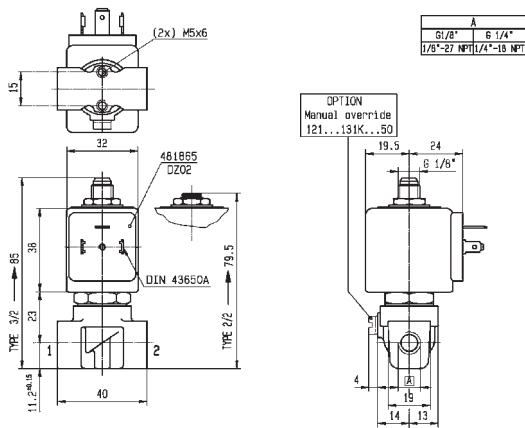
DISTRIBUTEURS 3 & 5 VOIES POUR COMMANDE D'ACTIONNEURS PNEUMATIQUES (RACCORD TUYAU) COMMANDE DIRECTE

LAITON
RACCORD TUYAU

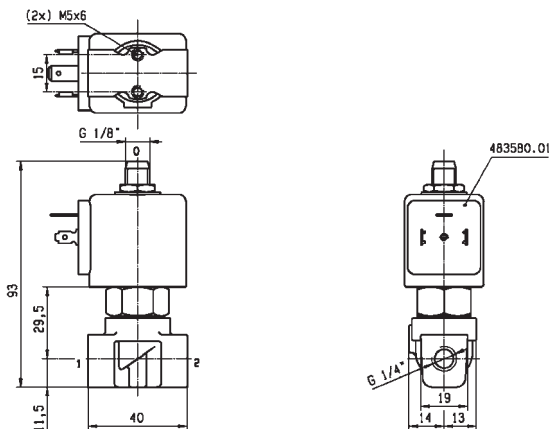
FERMÉE HORS TENSION

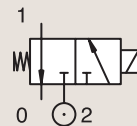

Raccord BSP	Orifice Ø 1 mm	Flow factor Qn l/min	Pression Différentielle			Temp. Fluide		Joint	Electrovannes PARKER LUCIFER®			Zone ATEX	Mode de Protection		Puissance		Groupe Electrique	N° Schéma
			Min bar	Max AC bar	Max DC bar	Min °C	Max °C		Ref. Valve	Ref. Boîtier	Ref. Bobine		AC W	DC W				
1/4"	1.5	80	0	-	7	-20	75	PUR	131K0497	2995	482740	-	-	-	1.6	6.0/8.0	8023	
	1.5	80	0	7	7	-20	75	PUR	131K0497	-	495900	1-21	Ex d mb IIC T4 to T6	2.5	2	6.0/8.0	8023	
	1.5	80	0	-	7	-20	75	PUR	131K0497	-	495910	0-20	Ex ia IIC T4 to T6	-	0.3 to 3	6.0/8.0	8023	
	1.5	80	0	-	7	-20	75	PUR	131K0497	2995	496125	2-22	Ex nAC IIC T5/T6	-	1.6	6.0/8.0	8023	
	1.5	80	0	16	16	-10	100	FKM	E131K04	2995	481865	-	-	8	9	2.0	3510	
	1.5	80	0	16	16	-10	120	FKM	E131K04	4270	481000	-	-	8	8	2.0	3510	
	1.5	80	0	16	16	-10	120	FKM	E131K04	4270	486265	-	-	14	14	2.0	3510	
	1.5	80	0	15	15	-10	100	FKM	E131K0450 ₁	2995	481865	-	-	8	9	2.1	3510	
	1.5	80	0	15	15	-10	120	FKM	E131K0450 ₁	4270	481000	-	-	8	8	2.1	3510	
	2	140	0	10	10	-10	100	FKM	E131K06	2995	481865	-	-	8	9	2.0	8119	
	2	140	0	10	10	-10	120	FKM	E131K06	4270	481000	-	-	8	8	2.0	8119	
	2	140	0	10	10	-10	120	FKM	E131K06	4270	486265	-	-	14	14	2.0	8119	
	2	140	0	10	10	-10	100	FKM	E131K0650 ₁	2995	481865	-	-	8	9	2.1	3510	
	2	140	0	10	10	-10	120	FKM	E131K0650 ₁	4270	481000	-	-	8	8	2.1	3510	

Notes:

1. Avec Commande manuelle



Dans cette page	Raccord	Orifice (mm)	Qn (l/min)	Pression Diff. Max. (bar)	Temp. Fluide (°C)	Temp. Amb. (°C)
de	1/4"	1.5	80	7	-20	-20
à	1/4"	2	140	16	120	50



Schéma 8023



Schéma 3510

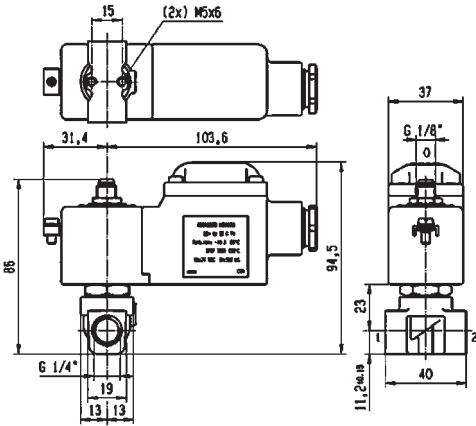

Schéma 8119

3/2

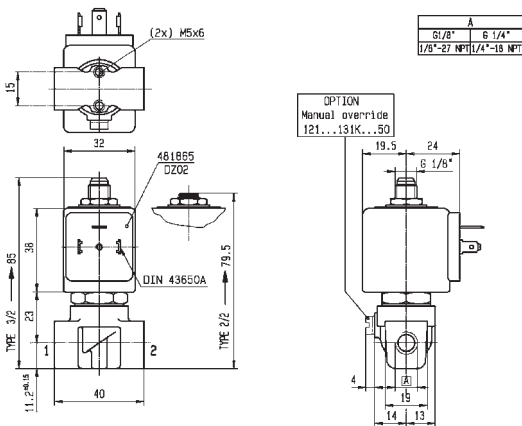
DISTRIBUTEURS 3 & 5 VOIES POUR COMMANDE D'ACTIONNEURS PNEUMATIQUES (RACCORD TUYAU) COMMANDE DIRECTE

LAITON

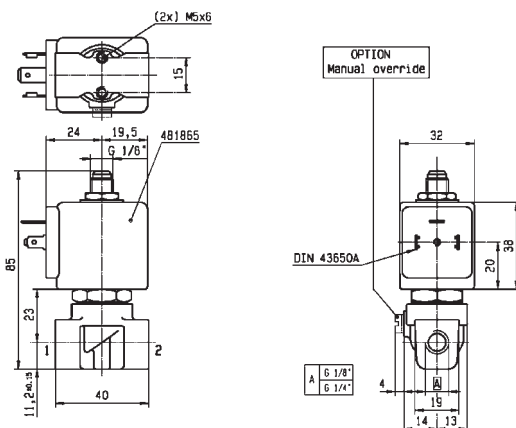
RACCORD TUYAU

FERMÉE HORS TENSION

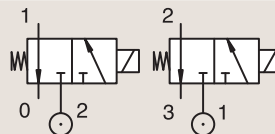

Raccord	Orifice Ø	Flow factor	Pression Différentielle			Temp. Fluide		Joint	Electrovannes PARKER LUCIFER®			Zone ATEX	Mode de Protection	Puissance		Groupe Electrique	N° Schéma
			Min	Max	DC bar	Min	Max		Ref. Valve	Ref. Boîtier	Ref. Bobine			AC W	DC W		
BSP	1																
	mm	Qn l/min	bar	AC bar	DC bar	°C	°C										
1/4"	2.5	220	0.1	7	7	-10	75	FKM	E131E03 ₂	2995	481865	-	-	8	9	2.0	3525
	2.5	220	0.1	7	7	-10	75	FKM	E131E03 ₂	4270	481000	-	-	8	8	2.0	3525
	2.5	220	0.1	7	7	-10	75	FKM	E131E03 ₂	4270	486265	-	-	14	14	2.0	3525
	2.5	220	0	7	7	-40	75	PUR	E131K0308	2995	481865	-	-	8	9	2.1	3510
	2.5	220	0	7	7	-40	75	PUR	E131K0308	4270	481000	-	-	8	8	2.1	3510
	2.5	220	0	7	7	-10	100	FKM	E131K0350 ₁	2995	481865	-	-	8	9	2.1	3510
	2.5	220	0	7	7	-10	120	FKM	E131K0350 ₁	4270	481000	-	-	8	8	2.1	3510
	4.5	500	0	2	2	-10	75	FKM	131T2101 ₁	2995	481865	-	-	8	9	2.1	3223
	4.5	500	0	2	2	-10	75	FKM	131T2101 ₁	4270	481000	-	-	8	8	2.1	3223

Notes:

- 1. Avec Commande manuelle
- 2. Echappement rapide

DISTRIBUTEURS PNEUMATIQUES 3 & 5 VOIES



Dans cette page	Raccord	Orifice (mm)	Qn (l/min)	Pression Diff. Max. (bar)	Temp. Fluide (°C)	Temp. Amb. (°C)
de	1/4"	2.5	220	2	-40	-40
à	1/4"	4.5	500	7	120	50



Schéma 3525



Schéma 3510

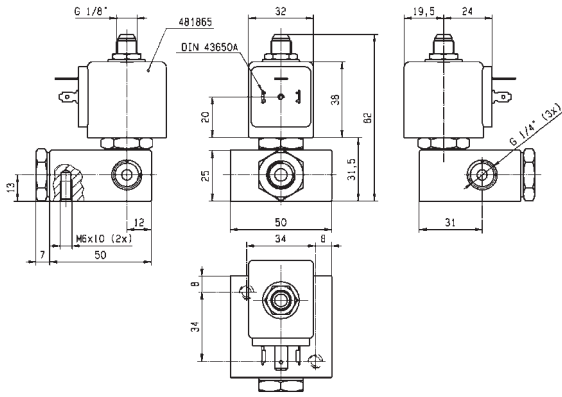

Schéma 3223

3/2

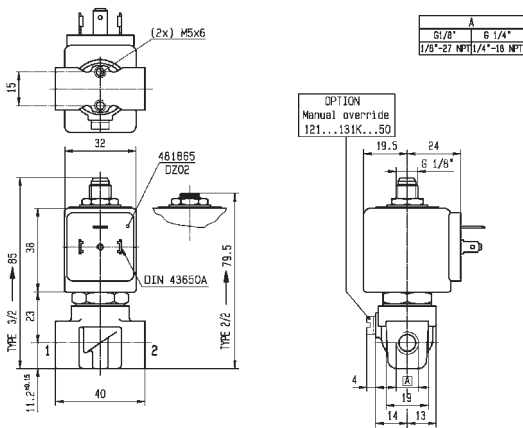
DISTRIBUTEURS 3 & 5 VOIES POUR COMMANDE D'ACTIONNEURS PNEUMATIQUES (RACCORD TUYAU) COMMANDE DIRECTE

LAITON

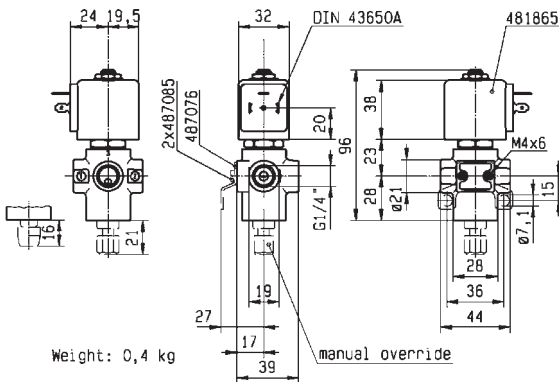
RACCORD TUYAU

OUVERTE HORS TENSION

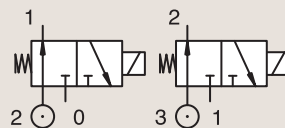

Raccord	Orifice Ø	Flow factor	Pression Différentielle			Temp. Fluide		Joint	Electrovannes PARKER LUCIFER®			Zone ATEX	Mode de Protection	Puissance		Groupe Electrique	N° Schéma
			Min	Max	DC bar	Min	Max		Ref. Valve	Ref. Boîtier	Ref. Bobine			AC W	DC W		
BSP	1																
	mm	Qn l/min	bar	AC bar	DC bar	°C	°C										
1/4"	2.5	220	0	7	3.5	-10	75	FKM	132T29	2995	481865	-	-	8	9	2.0	3223
	2.5	220	0	7	3.5	-10	75	FKM	132T29	4270	481000	-	-	8	8	2.0	3223
	2.5	220	0	-	7	-10	75	FKM	132T29	4270	486265	-	-	-	14	2.0	3223

LAITON

RACCORD TUYAU

UNIVERSELLE

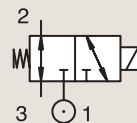

Raccord	Orifice Ø	Flow factor	Pression Différentielle			Temp. Fluide		Joint	Electrovannes PARKER LUCIFER®			Zone ATEX	Mode de Protection	Puissance		Groupe Electrique	N° Schéma
			Min	Max	DC bar	Min	Max		Ref. Valve	Ref. Boîtier	Ref. Bobine			AC W	DC W		
BSP	1																
	mm	Qn l/min	bar	AC bar	DC bar	°C	°C										
1/4" NPT	6	680	0	10	10	-25	65	NBR	U133X0111	-	492310	1-21	Ex e mb II T3 to T6	6	6	9.0/10.1/10.2	7422
	6	680	0	-	10	-25	75	NBR	U133X0111	-	492965.01	0-20	Ex ia IIC T6	-	0.3 to 3	9.0/10.1/10.2	7422
	6	680	0	10	10	-25	65	NBR	U133X01111D ₁	-	483270	1-21	Ex d IIC T4 to T6	8	8	11.0	7438

Notes:

1. Courant continu seulement. La chute de tension maximale admissible est égale à 15% de la valeur de tension nominale (DIN 19251)



Dans cette page	Raccord	Orifice (mm)	Qn (l/min)	Pression Diff. Max. (bar)	Temp. Fluide (°C)	Temp. Amb. (°C)
de	1/4"	2.5	220	3.5	-25	-25
à	1/4"	6	680	10	75	50



Schéma 3223



Schéma 7422

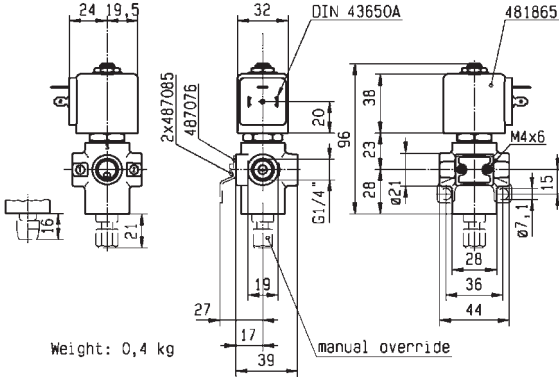

Schéma 7438

3/2

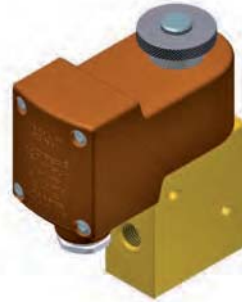
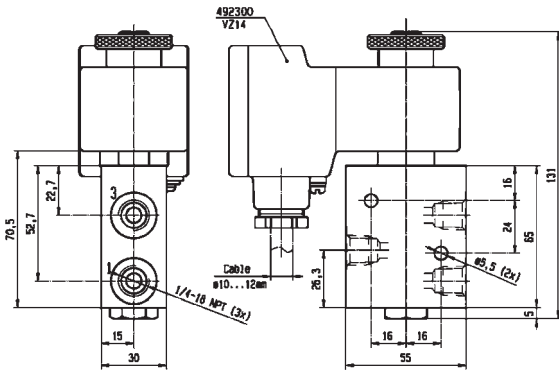
DISTRIBUTEURS 3 & 5 VOIES POUR COMMANDE D'ACTIONNEURS PNEUMATIQUES (RACCORD TUYAU) COMMANDE DIRECTE

LAITON

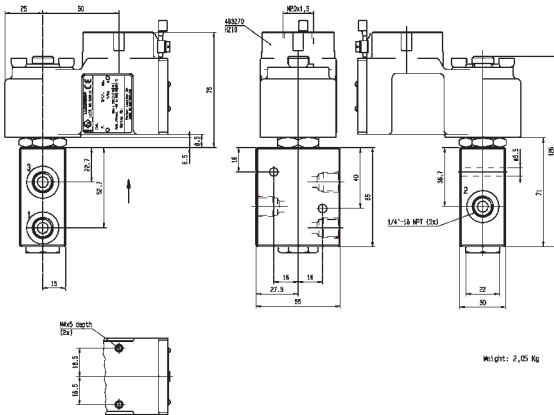
RACCORD TUYAU

UNIVERSELLE

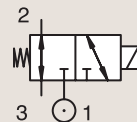

Raccord	Orifice Ø 1 mm	Flow factor Qn l/min	Pression Différentielle			Temp. Fluide		Joint	Electrovannes PARKER LUCIFER®			Zone ATEX	Mode de Protection	Puissance		Groupe Electrique	N° Schéma
			Min bar	Max AC bar	Max DC bar	Min °C	Max °C		Ref. Valve	Ref. Boîtier	Ref. Bobine			AC W	DC W		
1/4" NPT	6	680	0	-	10	-25	65	NBR	U133X0131	-	492310	1-21	Ex e mb II T3 to T6	-	6	10.1/10.2	8280
	6	680	0	-	10	-25	65	NBR	U133X0131	-	496700	1-21	Ex d mb IIC T4 to T6	-	6	10.1/10.2	8280

Notes:

1.Courant continu seulement. La chute de tension maximale admissible est égale à 15% de la valeur de tension nominale (DIN 19251)

LAITON

RACCORD TUYAU

CONTROLE PAR IMPULSION

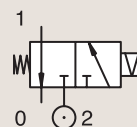

Raccord	Orifice Ø 1 mm	Flow factor Qn l/min	Pression Différentielle			Temp. Fluide		Joint	Electrovannes PARKER LUCIFER®			Zone ATEX	Mode de Protection	Puissance		Groupe Electrique	N° Schéma
			Min bar	Max AC bar	Max DC bar	Min °C	Max °C		Ref. Valve	Ref. Boîtier	Ref. Bobine			AC W	DC W		
1/4" BSP	2.5	220	0	-	7	-10	100	FKM	135K03	4269	485400	-	-	-	13	4.0	3510



Dans cette page	Raccord	Orifice (mm)	Qn (l/min)	Pression Diff. Max. (bar)	Temp. Fluide (°C)	Temp. Amb. (°C)
de	1/4"	2.5	220	7	-25	-25
à	1/4"	6	680	10	100	50



Schéma 8280



Schéma 3510

3/2

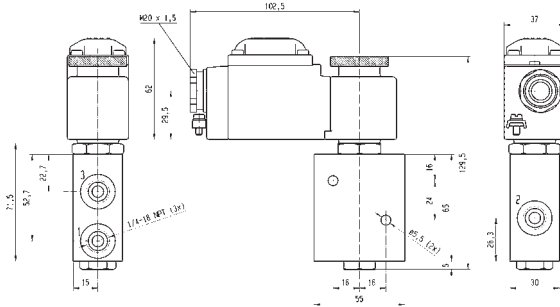
DISTRIBUTEURS 3 & 5 VOIES POUR COMMANDE D'ACTIONNEURS PNEUMATIQUES (RACCORD TUYAU) COMMANDE DIRECTE

LAITON

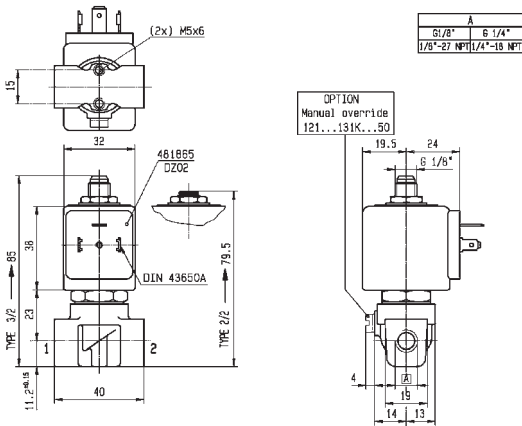
MONTAGE SUR EMBASE

FERMÉE HORS TENSION

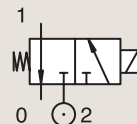

Raccord	Orifice Ø 1 mm	Flow factor Qn l/min	Pression Différentielle			Temp. Fluide		Joint	Electrovannes PARKER LUCIFER®			Zone ATEX	Mode de Protection	Puissance		Groupe Electrique	N° Schéma
			Min	Max		Min	Max		Ref. Valve	Ref. Boîtier	Ref. Bobine			AC W	DC W		
			bar	AC bar	DC bar	°C	°C										
SB	2.5	180	0	-	2	-20	75	PUR	131F4397	2995	482740	-	-	-	1.6	6.0/8.0	8022
	2.5	180	0	2	2	-20	75	PUR	131F4397	-	495900	1-21	Ex d mb IIC T4 to T6	2.5	2	6.0/8.0	8022
	2.5	180	0	-	2	-20	75	PUR	131F4397	-	495910	0-20	Ex ia IIC T4 to T6	-	0.3 to 3	6.0/8.0	8022
	2.5	180	0	-	2	-20	75	PUR	131F4397	2995	496125	2-22	Ex nAC IIC T5/T6	-	1.6	6.0/8.0	8022

LAITON

MONTAGE SUR EMBASE

UNIVERSELLE

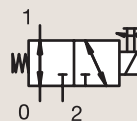

Raccord	Orifice Ø 1 mm	Flow factor Qn l/min	Pression Différentielle			Temp. Fluide		Joint	Electrovannes PARKER LUCIFER®			Zone ATEX	Mode de Protection	Puissance		Groupe Electrique	N° Schéma
			Min	Max		Min	Max		Ref. Valve	Ref. Boîtier	Ref. Bobine			AC W	DC W		
			bar	AC bar	DC bar	°C	°C										
SB	2	140	0	7	7	-10	100	FKM	133F4650 ₁	2995	481865	-	-	8	9	2.1	3509
	2	140	0	7	7	-10	120	FKM	133F4650 ₁	4270	481000	-	-	8	8	2.1	3509

Notes:

1. Avec Commande manuelle



Dans cette page	Raccord	Orifice (mm)	Qn (l/min)	Pression Diff. Max. (bar)	Temp. Fluide (°C)	Temp. Amb. (°C)
de	1/8"	2	140	2	-20	-20
à	5 mm	2.5	180	7	120	50



Schéma 8022



OPTION
Manual override
121...131F...50

Schéma 3509

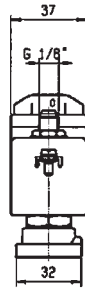
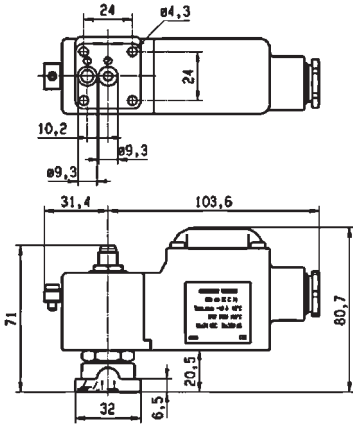
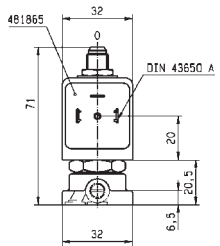
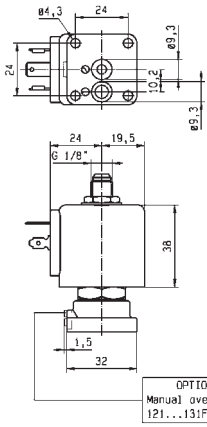
3/2

DISTRIBUTEURS 3 & 5 VOIES POUR COMMANDE D'ACTIONNEURS PNEUMATIQUES (RACCORD TUYAU) COMMANDE DIRECTE

ALUMINIUM ANODISÉ
RACCORD TUYAU

UNIVERSELLE

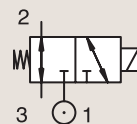

Raccord BSP	Orifice Ø 1 mm	Flow factor Qn l/min	Pression Différentielle			Temp. Fluide		Joint	Electrovannes PARKER LUCIFER®			Zone ATEX	Mode de Protection	Puissance		Groupe Electrique	N° Schéma
			Min bar	Max AC bar	Max DC bar	Min °C	Max °C		Ref. Valve	Ref. Boîtier	Ref. Bobine			AC W	DC W		
1/4"	6	680	0	10	10	-25	75	NBR	133X01	-	492310	1-21	Ex e mb II T3 to T6	6	6	9.0/10.1/10.2	6960
	6	680	0	-	10	-25	65	NBR	133X01	-	492965.01	0-20	Ex ia IIC T6	-	0.3 to 3	9.0/10.1/10.2	6960
	6	680	0	10	10	-25	65	NBR	133X01	-	496700	1-21	Ex d mb IIC T4 to T6	6	6	9.0/10.1/10.2	6960
	6	680	0	10	10	-25	65	NBR	133X01	-	496895	-	-	8	8	9.0/10.1/10.2	6960
	6	680	0	10	10	-25	80	FKM	133X01001D	-	483270	1-21	Ex d IIC T4 to T6	8	8	11.0	7031
1/4" NPT	6	680	0	10	10	-25	65	NBR	U133X01	-	496700	1-21	Ex d mb IIC T4 to T6	6	6	9.0/10.1/10.2	7422



Dans cette page	Raccord	Orifice (mm)	Qn (l/min)	Pression Diff. Max. (bar)	Temp. Fluide (°C)	Temp. Amb. (°C)
de	1/4"	6	680	10	-25	-25
à	1/4"	6	680	10	80	50



Schéma 6960



Schéma 7031

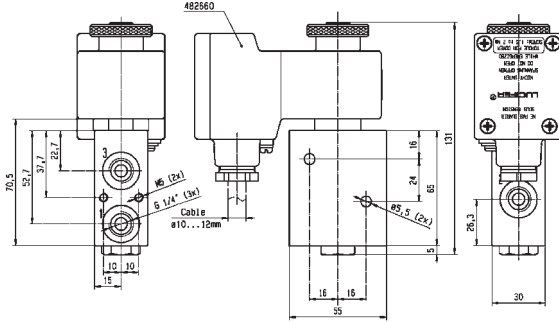

Schéma 7422

5/2

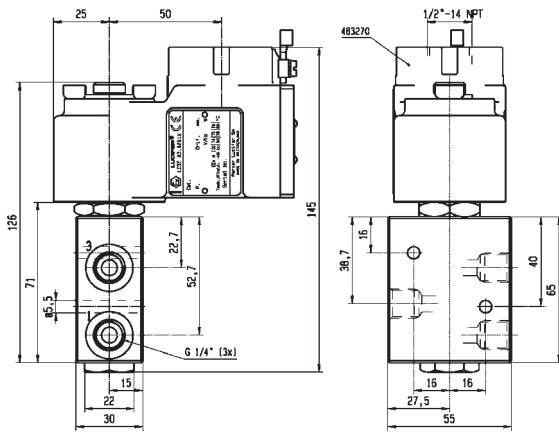
DISTRIBUTEURS 3 & 5 VOIES POUR COMMANDE D'ACTIONNEURS PNEUMATIQUES (RACCORD TUYAU) SERVO-COMMANDE

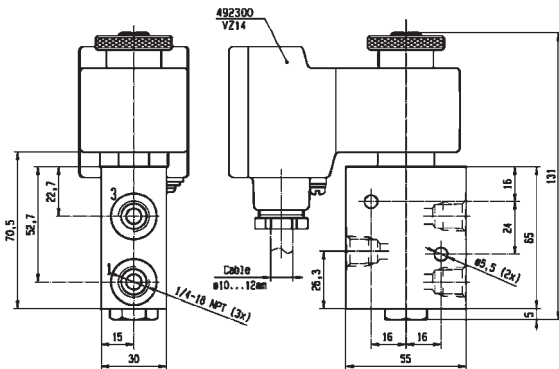

Process

ALUMINIUM ANODISÉ RACCORD TUYAU

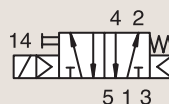

FERMÉE HORS TENSION

Raccord BSP	Orifice Ø 1	Flow factor Qn l/min	Pression Différentielle			Temp. Fluide		Joint	Electrovannes PARKER LUCIFER®			Zone ATEX	Mode de Protection	Puissance		Groupe Electrique	N° Schéma
			Min	Max	DC bar	Min	Max		Ref. Valve	Ref. Boîtier	Ref. Bobine			AC W	DC W		
1/8"	4	600	2	10	10	-25	50	NBR	341P01 ₁	-	482606	1-21	Ex mb IIC T4/T5	2	2.5	1.1	7302
	4	600	2	10	10	-25	80	NBR	341P01 ₁	8993	488980	-	-	2	2.5	1.1	7302
	4	600	2	10	10	-25	80	NBR	341P21 ₁₂	2995	481865	-	-	8	9	2.1	7296
	4	600	2	10	10	-25	80	NBR	341P21 ₁₂	4270	481000	-	-	8	8	2.1	7296
	4	600	2	10	10	-40	65	NBR/PUR	341P2108 ₁	2995	481865	-	-	8	9	2.1	7296
	4	600	2	10	10	-40	65	NBR/PUR	341P2108 ₁	4270	481000	-	-	8	8	2.1	7296
	4	600	2	-	10	-20	65	NBR/PUR	341P2197 ₁	2995	482740	-	-	-	1.6	6.0/8.0	8027
	4	600	2	10	10	-20	65	NBR/PUR	341P2197 ₁	-	495900	1-21	Ex d mb IIC T4 to T6	2.5	2	6.0/8.0	8027
	4	600	2	-	10	-20	65	NBR/PUR	341P2197 ₁	-	495910	0-20	Ex ia IIC T4 to T6	-	0.3 to 3	6.0/8.0	8027
	4	600	2	-	10	-20	65	NBR/PUR	341P2197 ₁	2995	496125	2-22	Ex nAC IIC T5/T6	-	1.6	6.0/8.0	8027

Notes:

- 1.Avec Commande manuelle
- 2.Joint du clapet de pilotage en FKM



Dans cette page	Raccord	Orifice (mm)	Qn (l/min)	Pression Diff. Max. (bar)	Temp. Fluide (°C)	Temp. Amb. (°C)
de	1/8"	4	600	10	-40	-40
à	1/8"	4	600	10	80	50



Schéma 7302



Schéma 7296

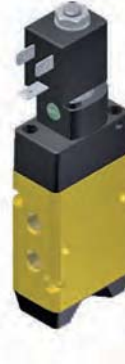
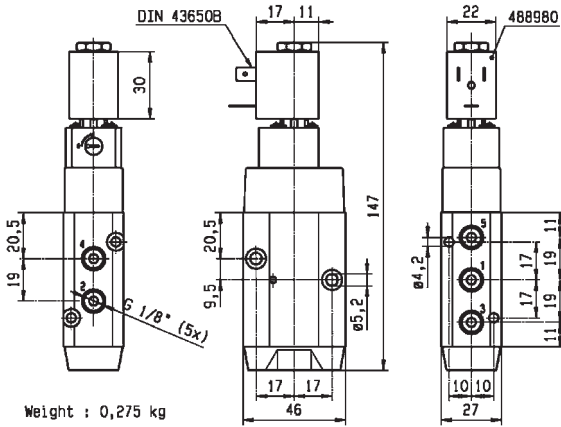

Schéma 8027

5/2

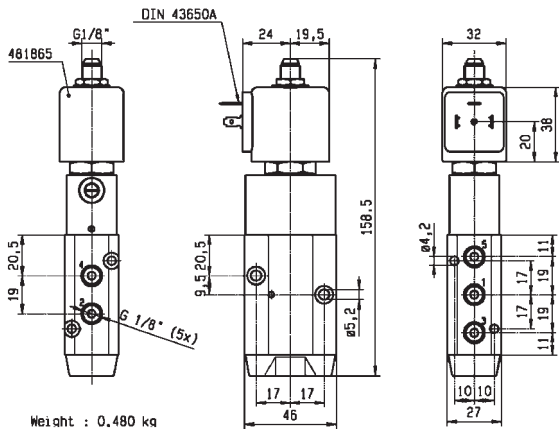
DISTRIBUTEURS 3 & 5 VOIES POUR COMMANDE D'ACTIONNEURS PNEUMATIQUES (RACCORD TUYAU) SERVO-COMMANDE

ALUMINIUM ANODISÉ RACCORD TUYAU

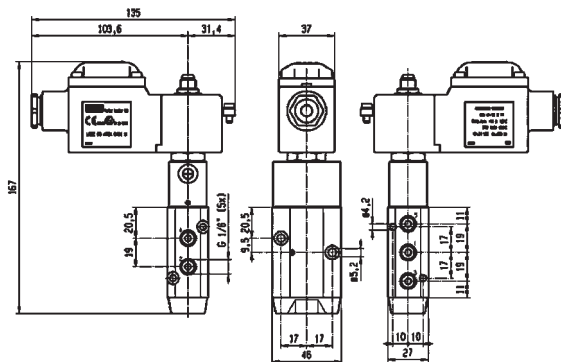
FERMÉE HORS TENSION

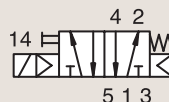

Raccord BSP	Orifice Ø 1	Flow factor Qn l/min	Pression Différentielle			Temp. Fluide		Joint	Electrovannes PARKER LUCIFER®			Zone ATEX	Mode de Protection	Puissance		Groupe Electrique	N° Schéma
			Min	Max	DC bar	Min	Max		Ref. Valve	Ref. Boîtier	Ref. Bobine			AC W	DC W		
1/8"	15	600	2	-	10	-10	55	NBR	341P2190 ₁	2995	483580.01	0-20	Ex ia IIC T6	-	0.5 to 3	7.0	7351
	15	600	2	-	10	-10	75	NBR	341P2190 ₁	-	488660.01	0-20	Ex ia IIC T6	-	0.3 to 3	7.0	7351
	15	600	2	-	10	-10	75	NBR	341P2190 ₁	-	495910	0-20	Ex ia IIC T4 to T6	-	0.3 to 3	7.0	7351
1/4"	7	1250	2.5	10	10	-10	50	NBR	341P03 ₁	-	496131	-	-	3	3	1.2	8218
	7	1250	2.5	10	10	-10	50	NBR	341P03 ₁	-	496482	-	-	3	3	1.2	8218
	7	1250	2.5	10	10	-10	50	NBR	341P03 ₁	-	496637	22	Ex tD A22 IP65 - T95°C	3	3	1.2	8218
	7	1250	2.5	10	10	-10	50	NBR	341P33 _{1,2}	2995	481865	-	-	8	9	2.1	8219
	7	1250	2.5	10	10	-10	50	NBR	341P33 _{1,2}	-	495870	2-22	Ex nAC IIC T3/T4	8	9	2.1	8219
	7	1250	2.5	10	10	-10	50	NBR	341P33 _{1,2}	-	495905	1-21	Ex d mb IIC T4	8	8	2.1	8219
	8	1400	2	10	10	-25	80	NBR	341P02 ₁	-	482606	1-21	Ex mb IIC T4/T5	2	2.5	1.1	7314
	8	1400	2	10	10	-25	80	NBR	341P02 ₁	8993	488980	-	-	2	2.5	1.1	7314

Notes:

- 1. Avec Commande manuelle
- 2. Joint du clapet de pilotage en FKM

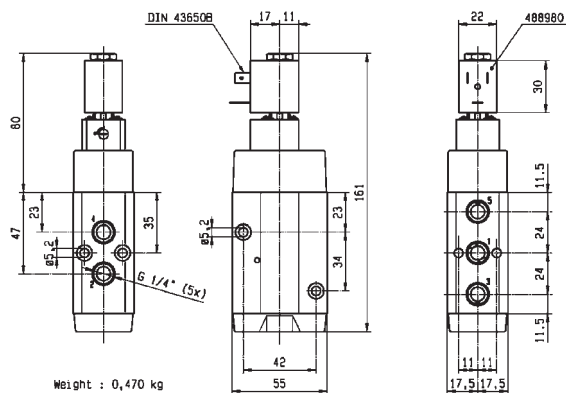

Weight : 0,470 kg



Schéma 7314



Dans cette page	Raccord	Orifice (mm)	Qn (l/min)	Pression Diff. Max. (bar)	Temp. Fluide (°C)	Temp. Amb. (°C)
de	1/8"	7	600	10	-25	-25
à	1/4"	15	1400	10	80	50



Schéma 7351



Schéma 8218

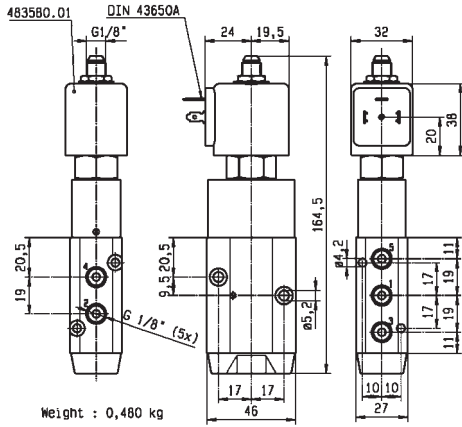

Schéma 8219

5/2

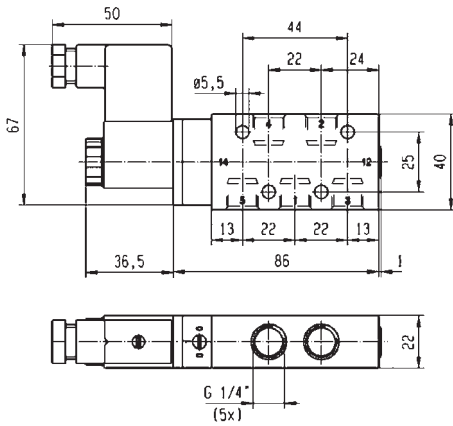
DISTRIBUTEURS 3 & 5 VOIES POUR COMMANDE D'ACTIONNEURS PNEUMATIQUES (RACCORD TUYAU) SERVO-COMMANDE

ALUMINIUM ANODISÉ
RACCORD TUYAU

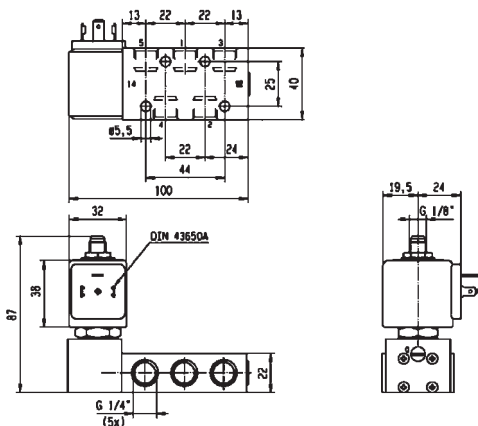
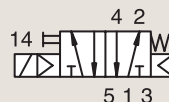

FERMÉE HORS TENSION

Raccord BSP	Orifice Ø 1 mm	Flow factor Qn l/min	Pression Différentielle			Temp. Fluide		Joint	Electrovannes PARKER LUCIFER®			Zone ATEX	Mode de Protection	Puissance		Groupe Electrique	N° Schéma
			Min bar	Max AC bar	Max DC bar	Min °C	Max °C		Ref. Valve	Ref. Boîtier	Ref. Bobine			AC W	DC W		
1/4"	8	1400	2	10	10	-25	80	NBR	341P22 _{1,2}	2995	481865	-	-	8	9	2.1	7319
	8	1400	2	10	10	-25	80	NBR	341P22 _{1,2}	4270	481000	-	-	8	8	2.1	7319
	8	1400	2	-	10	-25	55	NBR	341P2290	2995	483580.01	0-20	Ex ia IIC T6	-	0.5 to 3	7.0	7352
	8	1400	2	-	10	-25	75	NBR	341P2290	-	488660.01	0-20	Ex ia IIC T6	-	0.3 to 3	7.0	7352
	8	1400	2	-	10	-25	75	NBR	341P2290	-	495910	0-20	Ex ia IIC T4 to T6	-	0.3 to 3	7.0	7352
	8	1400	2	-	10	-20	80	NBR/ PUR	341P2297 ₁	2995	482740	-	-	-	1.6	6.0/8.0	8030
	8	1400	2	10	10	-20	80	NBR/ PUR	341P2297 ₁	-	495900	1-21	Ex d mb IIC T4 to T6	2.5	2	6.0/8.0	8030
	8	1400	2	-	10	-20	80	NBR/ PUR	341P2297 ₁	-	495910	0-20	Ex ia IIC T4 to T6	-	0.3 to 3	6.0/8.0	8030
8	1400	2	-	10	-20	80	NBR/ PUR	341P2297 ₁	2995	496125	2-22	Ex nAC IIC T5/T6	-	1.6	6.0/8.0	8030	

Notes:

1. Avec Commande manuelle
2. Joint du clapet de pilotage en FKM



Dans cette page	Raccord	Orifice (mm)	Qn (l/min)	Pression Diff. Max. (bar)	Temp. Fluide (°C)	Temp. Amb. (°C)
de	1/4"	8	1400	10	-25	-25
à	1/4"	8	1400	10	80	50



Schéma 7319



Schéma 7352

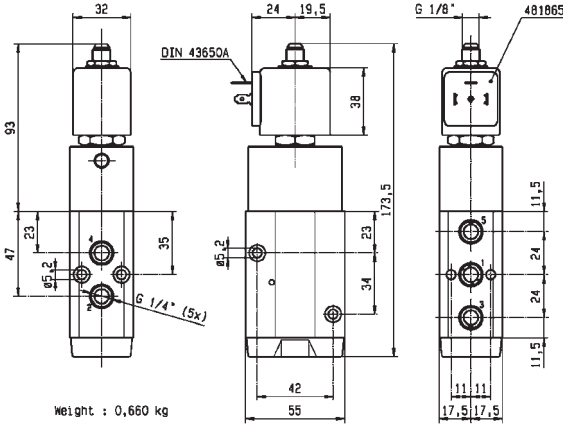

Schéma 8030

5/2

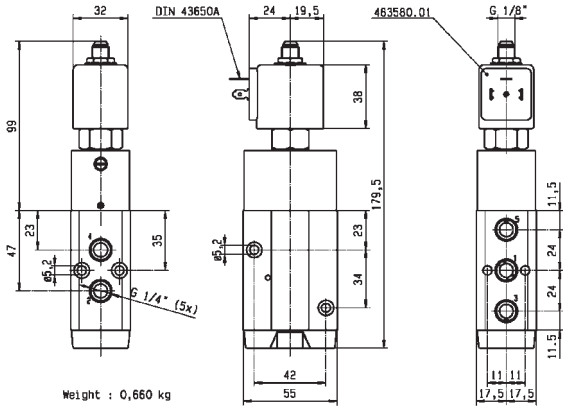
DISTRIBUTEURS 3 & 5 VOIES POUR COMMANDE D'ACTIONNEURS PNEUMATIQUES (RACCORD TUYAU) SERVO-COMMANDE

ALUMINIUM ANODISÉ

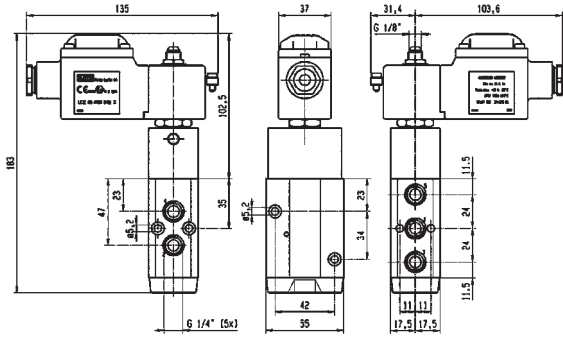
RACCORD TUYAU

FERMÉE HORS TENSION

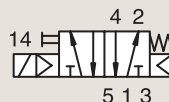

Raccord BSP	Orifice Ø 1 mm	Flow factor Qn l/min	Pression Différentielle			Temp. Fluide		Joint	Electrovannes PARKER LUCIFER®			Zone ATEX	Mode de Protection		Puissance		Groupe Electrique	N° Schéma
			Min bar	Max AC bar	Max DC bar	Min °C	Max °C		Ref. Valve	Ref. Boîtier	Ref. Bobine		AC W	DC W				
1/2"	12	3000	2.5	10	10	-10	50	NBR	341P04 ₁	-	496131	-	-	3	3	1.2	8220	
	12	3000	2.5	10	10	-10	50	NBR	341P04 ₁	-	496482	-	-	3	3	1.2	8220	
	12	3000	2.5	10	10	-10	50	NBR	341P04 ₁	-	496637	22	Ex tD A22 IP65 - T95°C	3	3	1.2	8220	
	12	3000	2.5	10	10	-10	50	NBR	341P34 ₁	2995	481865	-	-	8	9	2.1	8221	
	12	3000	2.5	10	10	-10	50	NBR	341P34 ₁	2995	495870	2-22	Ex nAC IIC T3/T4	8	9	2.1	8221	
	12	3000	2.5	10	10	-10	50	NBR	341P34 ₁	-	495905	1-21	Ex d mb IIC T4	8	8	2.1	8221	

Notes:

1. Avec Commande manuelle



Dans cette page	Raccord	Orifice (mm)	Qn (l/min)	Pression Diff. Max. (bar)	Temp. Fluide (°C)	Temp. Amb. (°C)
de	1/2"	12	3000	10	-10	-10
à	1/2"	12	3000	10	50	50



Schéma 8220



Schéma 8221

5/2

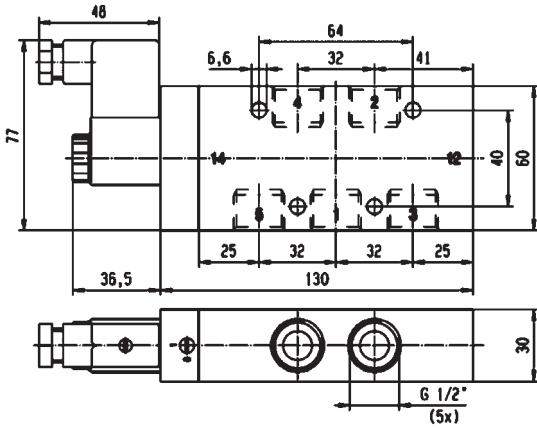
DISTRIBUTEURS 3 & 5 VOIES POUR COMMANDE D'ACTIONNEURS PNEUMATIQUES (RACCORD TUYAU) SERVO-COMMANDE

ALUMINIUM ANODISÉ
RACCORD TUYAU

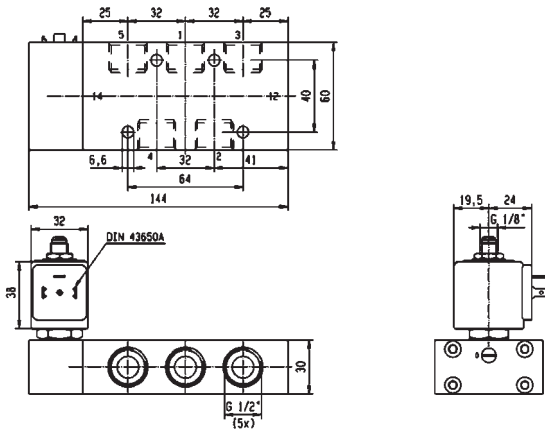
COMMANDE PAR 2 SOLENOIDES

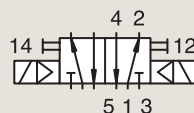

Raccord BSP	Orifice Ø 1	Flow factor Qn l/min	Pression Différentielle			Temp. Fluide		Joint	Electrovannes PARKER LUCIFER®			Zone ATEX	Mode de Protection	Puissance		Groupe Electrique	N° Schéma
			Min bar	Max AC bar	Max DC bar	Min °C	Max °C		Ref. Valve	Ref. Boîtier	Ref. Bobine			AC W	DC W		
1/8"	4	400	2	10	10	-25	80	NBR	347P01 ₁	-	482606	1-21	Ex mb IIC T4/T5	2	2.5	1.1	7306
	4	400	2	10	10	-25	80	NBR	347P01 ₁	8993	488980	-	-	2	2.5	1.1	7306
	4	400	2	10	10	-25	80	NBR	347P21 ₁₂	2995	481865	-	-	8	9	2.1	7298
	4	400	2	10	10	-25	80	NBR	347P21 ₁₂	4270	481000	-	-	8	8	2.1	7298
	4	400	2	-	10	-25	55	NBR	347P2190	2995	483580.01	0-20	Ex ia IIC T6	-	0.5 to 3	7.0	7353
	4	400	2	-	10	-25	75	NBR	347P2190	-	488660.01	0-20	Ex ia IIC T6	-	0.3 to 3	7.0	7353
	4	400	2	-	10	-25	75	NBR	347P2190	-	495910	0-20	Ex ia IIC T4 to T6	-	0.3 to 3	7.0	7353
	4	400	2	-	10	-20	65	NBR/ PUR	347P2197 ₁	2995	482740	-	-	-	1.6	6.0/8.0	8028
	4	400	2	10	10	-20	65	NBR/ PUR	347P2197 ₁	-	495900	1-21	Ex d mb IIC T4 to T6	2.5	2	6.0/8.0	8028
	4	400	2	-	10	-20	65	NBR/ PUR	347P2197 ₁	-	495910	0-20	Ex ia IIC T4 to T6	-	0.3 to 3	6.0/8.0	8028
4	400	2	-	10	-20	65	NBR/ PUR	347P2197 ₁	2995	496125	2-22	Ex nAC IIC T5/T6	-	1.6	6.0/8.0	8028	

Notes:

1. Avec Commande manuelle
2. Joint du clapet de pilotage en FKM



Schéma 8028



Dans cette page	Raccord	Orifice (mm)	Qn (l/min)	Pression Diff. Max. (bar)	Temp. Fluide (°C)	Temp. Amb. (°C)
de	1/8"	4	400	10	-25	-25
à	1/8"	4	400	10	80	50

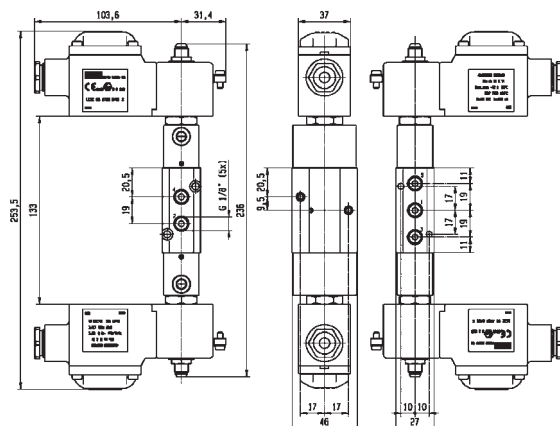

Schéma 7306



Schéma 7298

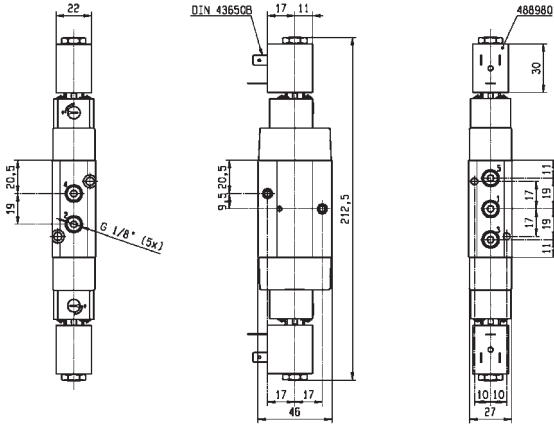

Schéma 7353

5/2

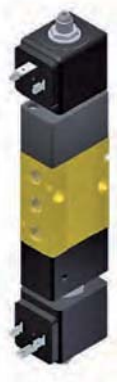
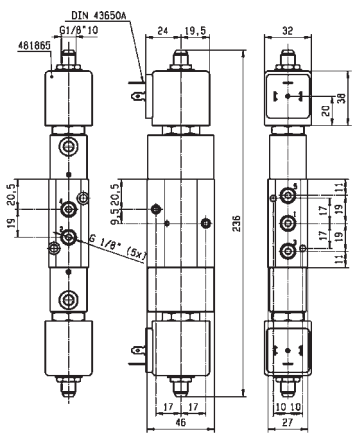
DISTRIBUTEURS 3 & 5 VOIES POUR COMMANDE D'ACTIONNEURS PNEUMATIQUES (RACCORD TUYAU) SERVO-COMMANDE

ALUMINIUM ANODISÉ RACCORD TUYAU

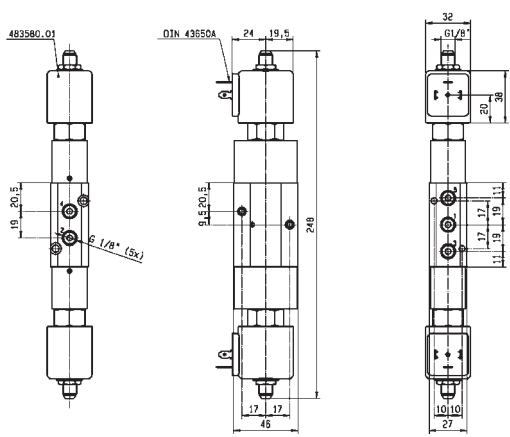
COMMANDE PAR 2 SOLENOIDES

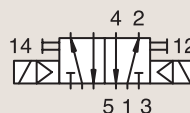

Raccord BSP	Orifice Ø 1 mm	Flow factor Qn l/min	Pression Différentielle			Temp. Fluide		Joint	Electrovannes PARKER LUCIFER®			Zone ATEX	Mode de Protection	Puissance		Groupe Electrique	N° Schéma
			Min bar	Max AC bar	Max DC bar	Min °C	Max °C		Ref. Valve	Ref. Boîtier	Ref. Bobine			AC W	DC W		
1/4"	7	1250	2.5	10	10	-10	50	NBR	347P03 ₁	-	496131	-	-	3	3	1.2	8222
	7	1250	2.5	10	10	-10	50	NBR	347P03 ₁	-	496482	-	-	3	3	1.2	8222
	7	1250	2.5	10	10	-10	50	NBR	347P03 ₁	-	496637	22	Ex tD A22 IP65 - T95°C	3	3	1.2	8222
	7	1250	2.5	10	10	-10	50	NBR	347P33 ₁	2995	481865	-	-	8	9	2.1	8223
	7	1250	2.5	10	10	-10	50	NBR	347P33 _{1,2}	2995	495870	2-22	Ex nAC IIC T3/T4	8	9	2.1	8223
	7	1250	2.5	10	10	-10	50	NBR	347P33 _{1,2}	-	495905	1-21	Ex d mb IIC T4	8	8	2.1	8223
	8	1400	2	10	10	-25	80	NBR	347P02 ₁	-	482606	1-21	Ex mb IIC T4/T5	2	2.5	1.1	7316
	8	1400	2	10	10	-25	80	NBR	347P02 ₁	8993	488980	-	-	2	2.5	1.1	7316
	8	1400	2	10	10	-25	80	NBR	347P22 _{1,2}	2995	481865	-	-	8	9	2.1	7321
8	1400	2	10	10	-25	80	NBR	347P22 _{1,2}	4270	481000	-	-	8	8	2.1	7321	

Notes:

1. Avec Commande manuelle
2. Joint du clapet de pilotage en FKM



Schéma 7321



Dans cette page	Raccord	Orifice (mm)	Qn (l/min)	Pression Diff. Max. (bar)	Temp. Fluide (°C)	Temp. Amb. (°C)
de	1/4"	7	1250	10	-25	-25
à	1/4"	8	1400	10	80	50

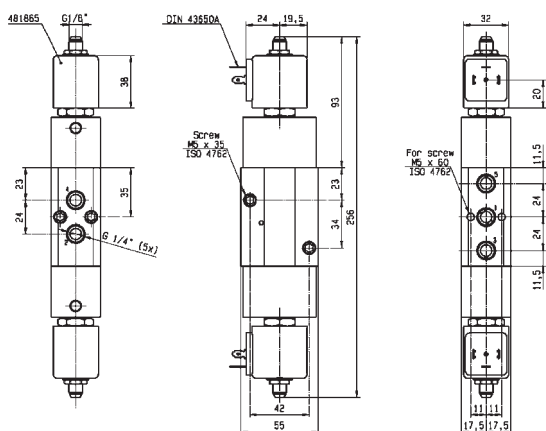

Schéma 8222



Schéma 8223

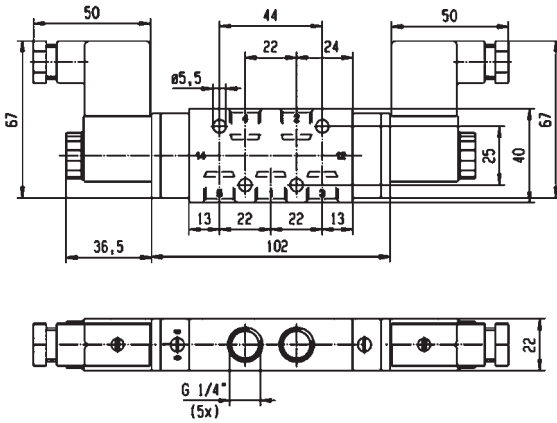

Schéma 7316

5/2

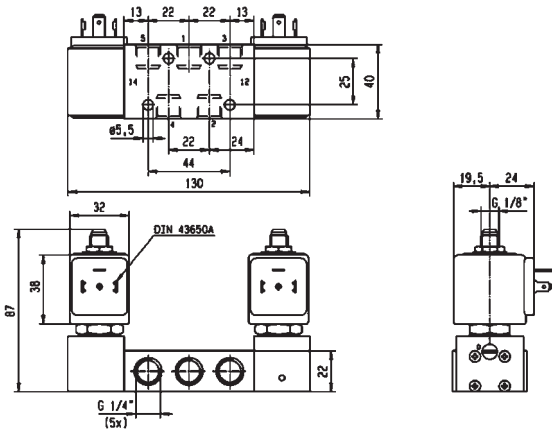
DISTRIBUTEURS 3 & 5 VOIES POUR COMMANDE D'ACTIONNEURS PNEUMATIQUES (RACCORD TUYAU) SERVO-COMMANDE

ALUMINIUM ANODISÉ

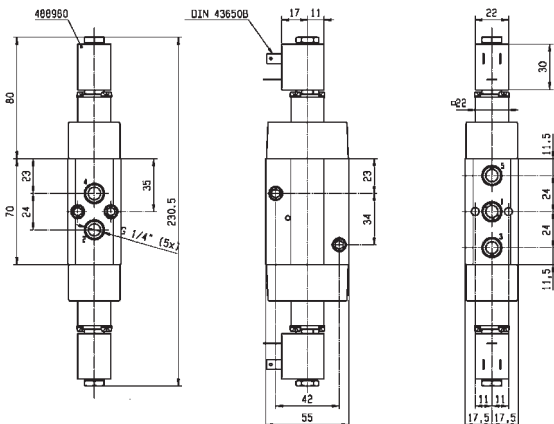
RACCORD TUYAU

COMMANDE PAR 2 SOLENOIDES

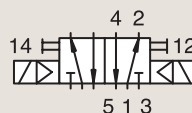

Raccord	Orifice Ø	Flow factor	Pression Différentielle			Temp. Fluide		Joint	Electrovannes PARKER LUCIFER®			Zone ATEX	Mode de Protection	Puissance		Groupe Electrique	N° Schéma
			Min	Max	DC bar	Min	Max		Ref. Valve	Ref. Boîtier	Ref. Bobine			AC W	DC W		
BSP	1																
	mm	Qn l/min	bar	AC bar	DC bar	°C	°C										
1/2"	12	3000	2.5	10	10	-10	50	NBR	347P04 ₁	-	496131	-	-	3	3	1.2	8224
	12	3000	2.5	10	10	-10	50	NBR	347P04 ₁	-	496482	-	-	3	3	1.2	8224
	12	3000	2.5	10	10	-10	50	NBR	347P04 ₁	-	496637	22	Ex tD A22 IP65 - T95°C	3	3	1.2	8224
	12	3000	2.5	10	10	-10	50	NBR	347P34 _{1,2}	2995	481865	-	-	8	9	2.1	8225
	12	3000	2.5	10	10	-10	50	NBR	347P34 _{1,2}	2995	495870	2-22	Ex nAC IIC T3/T4	8	9	2.1	8225
	12	3000	2.5	10	10	-10	50	NBR	347P34 _{1,2}	-	495905	1-21	Ex d mb IIC T4	8	8	2.1	8225

Notes:

1. Avec Commande manuelle
2. Joint du clapet de pilotage en FKM

ALUMINIUM ANODISÉ

RACCORD TUYAU

CONTROLE PAR IMPULSION

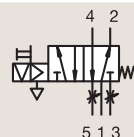

Raccord	Orifice Ø	Flow factor	Pression Différentielle			Temp. Fluide		Joint	Electrovannes PARKER LUCIFER®			Zone ATEX	Mode de Protection	Puissance		Groupe Electrique	N° Schéma
			Min	Max	DC bar	Min	Max		Ref. Valve	Ref. Boîtier	Ref. Bobine			AC W	DC W		
BSP	1																
	mm	Qn l/min	bar	AC bar	DC bar	°C	°C										
1/8"	4	600	2	-	10	-25	80	NBR	345P21	4269	485400	-	-	-	13	4.0	8123

3/2

DISTRIBUTEURS 3 & 5 VOIES POUR COMMANDE D'ACTIONNEURS PNEUMATIQUES (RACCORD TUYAU) RÉARMEMENT MANUEL



Process

LAITON RACCORD TUYAU

UNIVERSELLE

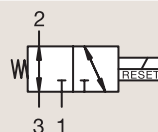

Raccord	Orifice Ø	Flow factor Qn l/min	Pression Différentielle			Temp. Fluide		Joint	Electrovannes PARKER LUCIFER®			Zone ATEX	Mode de Protection	Puissance		Groupe Electrique	N° Schéma
			Min bar	Max		Min °C	Max °C		Ref. Valve	Ref. Boîtier	Ref. Bobine			AC W	DC W		
				AC bar	DC bar												
1/4" NPT	6	680	0	10	10	-25	65	NBR	U033X0111	-	492310	1-21	Ex e mb II T3 to T6	6	6	10.1/10.2/12.0	7641
	6	680	0	10	10	-25	65	NBR	U033X0111	-	496700	1-21	Ex d mb IIC T4 to T6	6	6	10.1/10.2/12.0	7641



Dans cette page	Raccord	Orifice (mm)	Qn (l/min)	Pression Diff. Max. (bar)	Temp. Fluide (°C)	Temp. Amb. (°C)
de	1/4"	6	680	10	-25	-25
à	1/4"	6	680	10	65	65



Schéma 7641

DISTRIBUTEURS 3 & 5 VOIES POUR COMMANDE D'ACTIONNEURS PNEUMATIQUES



DISTRIBUTEURS 3 & 5 VOIES POUR COMMANDE D'ACTIONNEURS PNEUMATIQUES (NAMUR)

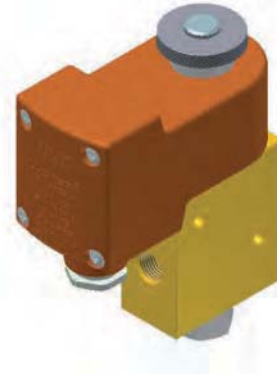
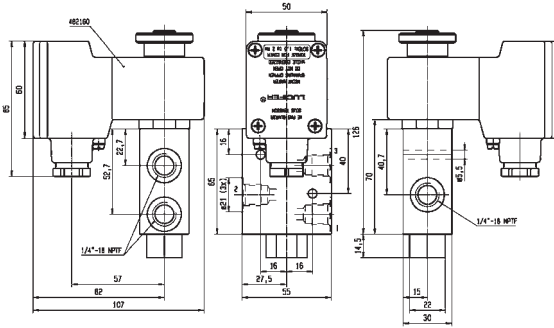

Air

3/2
5/2
5/3

Commande	Corps de Valve	Fonction	Raccord	Orifice (mm)	Facteur d'Écoulement Qn(l/min)	Pression Différentielle (bar)	Temp. Max. Fluide (°C)	Page Valves Parker	Page Valves Parker LUCIFER®
Commande Directe	Aluminium anodisé/ NAMUR	Fermée hors tension	1/4"	6	680	10	75	-	334
Servo-commande	Aluminium anodisé/ NAMUR/Tiroir	Commande par Solénoïde-rappel par ressort	1/8"-1/4"	4 à 8	1400	10	80	-	340
			1/4"	7 à 8	1400	10	80	-	336
			1/2"	12	3000	10	50	-	336
		Double Bobines	1/8"-1/4"	4	400	10	80	-	352
			1/4"	7 à 8	1400	10	120	-	354
			1/2"	12	3000	10	120	-	356
		W1 fermée en position centrale	1/8"-1/4"	4	400	10	80	-	358
			1/4"	4 à 7	1250	10	120	-	358
		W3 à l'échappement en position centrale	1/4"	7	1250	10	50	-	360
		Controlée par Impulsion Electrique	1/8"-1/4"	4	600	10	80	-	362
Pilotage externe	Aluminium anodisé/ NAMUR/Clapet	Commande par Solénoïde-rappel par ressort	1/8"-1/4"	4	355	10	75	-	362
	Aluminium anodisé/ NAMUR	W1 fermée en position centrale	1/4"	7	1250	10	50	-	372
			Commande par air - rappel par ressort	1/8"-1/4"	4	600	10	80	-
		1/4"	7	1250	10	50	-	366	
		1/2"	12	3000	10	50	-	366	
Commande et rappel par air	1/4"	7	1250	10	50	-	370		

3/2

DISTRIBUTEURS 3 & 5 VOIES POUR COMMANDE D'ACTIONNEURS PNEUMATIQUES (NAMUR) COMMANDE DIRECTE



Process

**ALUMINIUM ANODISÉ
NAMUR**

FERMÉE HORS TENSION

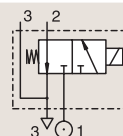

Raccord BSP	Orifice Ø 1	Facteur d'Écoulement Qn l/min	Pression Différentielle			Temp. Fluide		Joint	Electrovannes PARKER LUCIFER®			Zone ATEX	Mode de Protection	Puissance		Groupe Electrique	N° Schéma
			Min bar	Max AC bar	Max DC bar	Min °C	Max °C		Ref. Valve	Ref. Boîtier	Ref. Bobine			AC W	DC W		
1/4"	6	680	0	10	10	-25	75	NBR	131X1101	-	492310	1-21	Ex e mb II T3 to T6	6	6	9.0/10.1	7336
	6	680	0	-	10	-25	75	NBR	131X1101	-	492965.01	0-20	Ex ia IIC T6	-	0.3 to 3	9.0/10.1	7336
	6	680	0	10	10	-25	75	NBR	131X1101	-	496700	1-21	Ex d mb IIC T4 to T6	6	6	9.0/10.1	7336
	6	680	0	10	10	-25	75	NBR	131X1101	-	496895	-	-	8	8	9.0/10.1	7336
	6	680	0	-	10	-25	65	NBR	131X1131 ₁	-	492310	1-21	Ex e mb II T3 to T6	-	6	10.1/10.2	7336
	6	680	0	-	10	-25	65	NBR	131X1131 ₁	-	496700	1-21	Ex d mb IIC T4 to T6	-	6	10.1/10.2	7336
	6	680	0	-	10	-25	65	NBR	131X1131 ₁	-	496895	-	-	-	8	10.1/10.2	7336
1/4" NPT	6	680	0	-	10	-25	75	NBR	U131X1101	-	492965.01	0-20	Ex ia IIC T6	-	0.3 to 3	10.1/10.2	7336
	6	680	0	10	10	-25	65	NBR	U131X1101	-	496700	1-21	Ex d mb IIC T4 to T6	6	6	10.1/10.2	7336
	6	680	0	10	10	-25	65	NBR	U131X1101	-	496895	-	-	8	8	10.1/10.2	7336

Notes:

1. Courant continu seulement. La chute de tension maximale admissible est égale à 15% de la valeur de tension nominal (DIN19251)



Dans cette page	Raccord	Orifice (mm)	Qn (l/min)	Pression Diff. Max. (bar)	Temp. Fluide (°C)	Temp. Amb. (°C)
de	1/4"	6	680	10	-25	-25
à	1/4"	6	680	10	75	65



Schéma 7336

3/2

DISTRIBUTEURS 3 & 5 VOIES POUR COMMANDE D'ACTIONNEURS PNEUMATIQUES (NAMUR) SERVO-COMMANDE

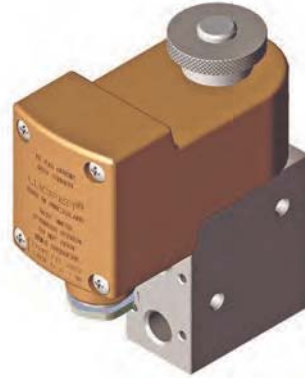
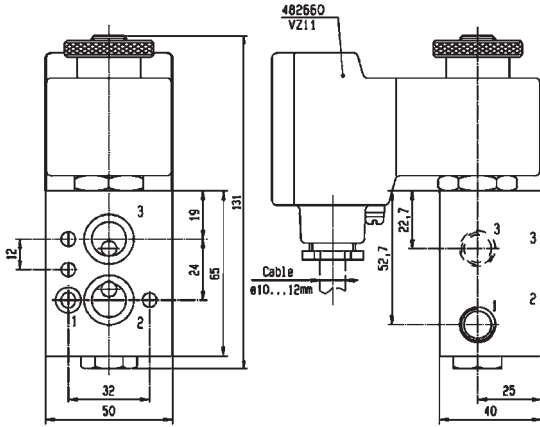

Process

ALUMINIUM ANODISÉ NAMUR

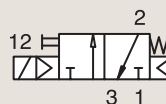

COMMANDE PAR SOLENOÏDE-RAPPEL PAR RESSORT

Raccord BSP	Orifice Ø 1 mm	Facteur d'Écoulement Qn l/min	Pression Différentielle			Temp. Fluide		Joint	Electrovannes PARKER LUCIFER®			Zone ATEX	Mode de Protection	Puissance		Groupe Electrique	N° Schéma
			Min bar	Max AC bar	Max DC bar	Min °C	Max °C		Ref. Valve	Ref. Boîtier	Ref. Bobine			AC W	DC W		
1/4"	7	1250	2.5	10	10	-10	50	NBR	331N03 ₁	-	496131	-	-	3	3	1.2	8056
	7	1250	2.5	10	10	-10	50	NBR	331N03 ₁	-	496482	-	-	3	3	1.2	8056
	7	1250	2.5	10	10	-10	50	NBR	331N03 ₁	-	496637	22	Ex tD A22 IP65 - T95°C	3	3	1.2	8056
1/2"	12	3000	2	10	10	-10	50	NBR	331N04 ₁	-	496131	-	-	3	3	1.2	8060
	12	3000	2	10	10	-10	50	NBR	331N04 ₁	-	496482	-	-	3	3	1.2	8060
	12	3000	2	10	10	-10	50	NBR	331N04 ₁	-	496637	22	Ex tD A22 IP65 - T95°C	3	3	1.2	8060
	12	3000	2	10	10	-10	50	NBR	331N0402	-	496131	-	-	3	3	1.2	8251
	12	3000	2	10	10	-10	50	NBR	331N0402	-	496482	-	-	3	3	1.2	8251

Notes:

1. Avec Commande manuelle



Dans cette page	Raccord	Orifice (mm)	Qn (l/min)	Pression Diff. Max. (bar)	Temp. Fluide (°C)	Temp. Amb. (°C)
de	1/4"	7	1250	10	-10	-10
à	1/2"	12	3000	10	50	50



Schéma 8056



Schéma 8060

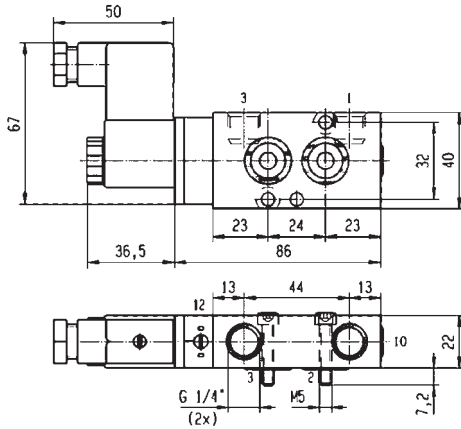

Schéma 8251

3/2

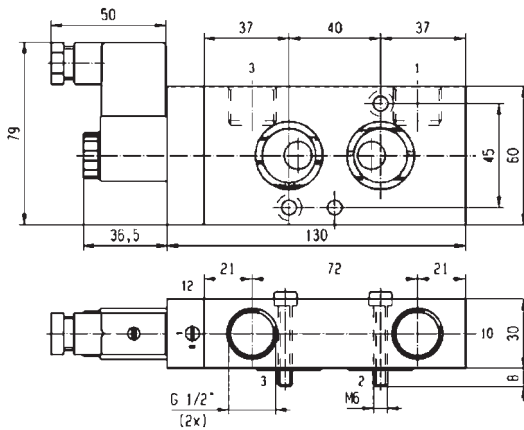
DISTRIBUTEURS 3 & 5 VOIES POUR COMMANDE D'ACTIONNEURS PNEUMATIQUES (NAMUR) SERVO-COMMANDE

ALUMINIUM ANODISÉ

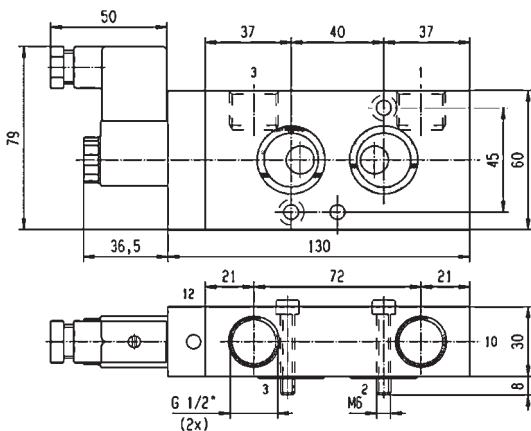
NAMUR

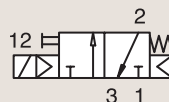

COMMANDE PAR SOLENOÏDE-RAPPEL PAR RESSORT

Raccord	Orifice Ø	Facteur d'Écoulement	Pression Différentielle			Temp. Fluide		Joint	Electrovannes PARKER LUCIFER®			Zone ATEX	Mode de Protection	Puissance		Groupe Électrique	N° Schéma
			Min	Max	DC bar	Min	Max		Ref. Valve	Ref. Boîtier	Ref. Bobine			AC W	DC W		
BSP	1	Qn l/min	bar	AC bar	DC bar	°C	°C										
1/2"	12	3000	2.5	10	10	-10	50	NBR	331N34 ₁₂	2995	481865	-	-	8	9	2.1	8210
	12	3000	2.5	10	10	-10	50	NBR	331N34 ₁₂	2995	495870	2-22 Ex nAC IIC T3/T4		8	9	2.1	8210
	12	3000	2.5	10	10	-10	50	NBR	331N34 ₁₂	-	495905	1-21 Ex d mb IIC T4		8	8	2.1	8210
	12	3000	2.5	10	10	-10	50	NBR	331N3402 ₂	2995	481865	-	-	8	9	2.1	8252

Notes:

- 1. Avec Commande manuelle
- 2. Clopet de pilotage FKM



Dans cette page	Raccord	Orifice (mm)	Qn (l/min)	Pression Diff. Max. (bar)	Temp. Fluide (°C)	Temp. Amb. (°C)
de	1/2"	12	3000	10	-10	-10
à	1/2"	12	3000	10	50	50



Schéma 8210



Schéma 8252

3/2-5/2

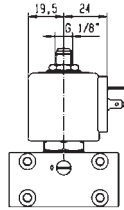
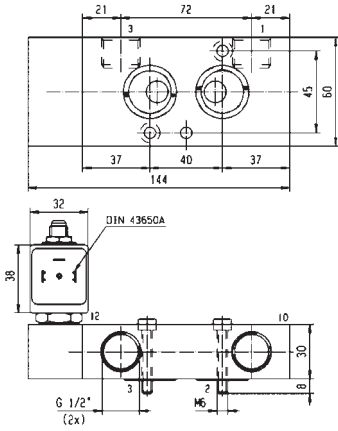
DISTRIBUTEURS 3 & 5 VOIES POUR COMMANDE D'ACTIONNEURS PNEUMATIQUES (NAMUR) SERVO-COMMANDE

**ALUMINIUM ANODISÉ
NAMUR**

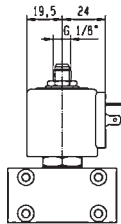
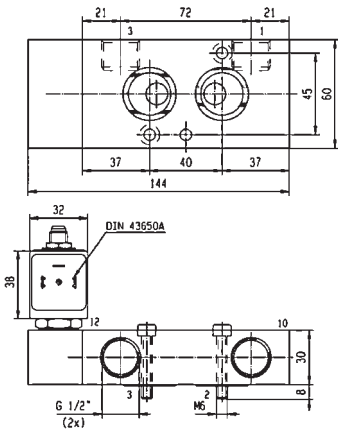
COMMANDE PAR SOLENOÏDE-RAPPEL PAR RESSORT

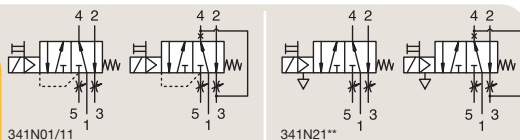

Raccord BSP	Orifice Ø 1	Facteur d'Écoulement Qn l/min	Pression Différentielle		Temp. Fluide		Joint	Electrovannes PARKER LUCIFER®			Zone ATEX	Mode de Protection	Puissance		Groupe Electrique	N° Schéma	
			Min AC bar	Max DC bar	Min °C	Max °C		Ref. Valve	Ref. Boîtier	Ref. Bobine			AC W	DC W			
1/8"- 1/4"	4	600	2	10	10	-25	80	NBR	341N01 ₁₂	8993	488980	-	-	2	2.5	1.1	7301
	4	600	2	10	10	-25	80	NBR	341N11 ₁₂	8993	488980	-	-	2	2.5	1.1	7300
	4	600	2	10	10	-25	80	FKM/NBR	341N21 ₁	2995	481865	-	-	8	9	2.1	7311
	4	600	2	10	10	-25	80	FKM/NBR	341N21 ₁	4270	481000	-	-	8	8	2.1	7311
	4	600	2	-	10	-25	55	FKM/NBR	341N2190 ₁	2995	483580.01	0-20	Ex ia IIC T6	-	0.5 to 3	7.0/8.0	7874
	4	600	2	-	10	-25	55	FKM/NBR	341N2190 ₁	-	495910	0-20	Ex ia IIC T4 to T6	-	0.3 to 3	7.0/8.0	7874

Notes:

- 1.Avec Commande manuelle
- 2.Avec échappement collecté



Schéma 7874



Dans cette page	Raccord	Orifice (mm)	Qn (l/min)	Pression Diff. Max. (bar)	Temp. Fluide (°C)	Temp. Amb. (°C)
de	1/8"-1/4"	4	600	10	-25	-25
à	1/8"-1/4"	4	600	10	80	50

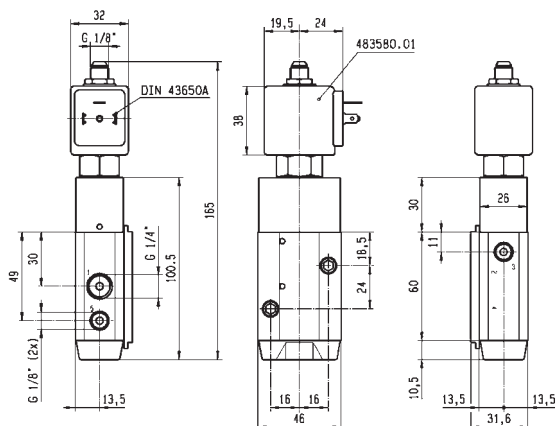

Schéma 7301



Schéma 7300

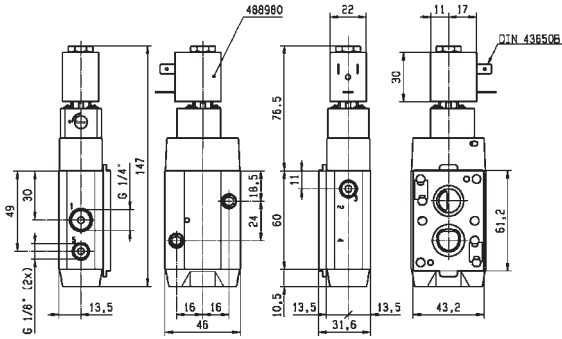

Schéma 7311

3/2-5/2

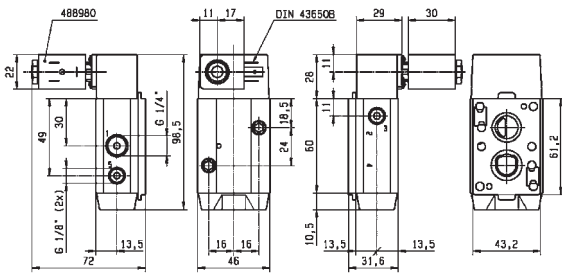
**DISTRIBUTEURS 3 & 5 VOIES POUR COMMANDE
D'ACTIONNEURS PNEUMATIQUES (NAMUR)
SERVO-COMMANDE**

**ALUMINIUM ANODISÉ
NAMUR**

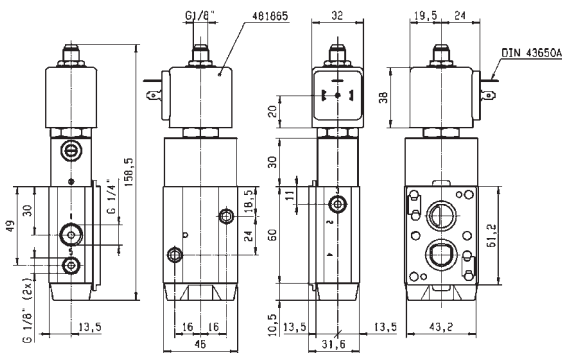
COMMANDE PAR SOLENOÏDE-RAPPEL PAR RESSORT

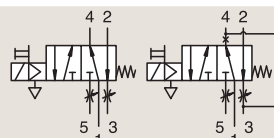

Raccord BSP	Orifice Ø 1	Facteur d'Écoulement Qn l/min	Pression Différentielle		Temp. Fluide		Joint	Electrovannes PARKER LUCIFER®			Zone ATEX	Mode de Protection	Puissance		Groupe Électrique	N° Schéma	
			Min AC bar	Max DC bar	Min °C	Max °C		Ref. Valve	Ref. Boîtier	Ref. Bobine			AC W	DC W			
1/8"- 1/4"	4	600	2	10	10	-25	80	NBR	341N31 ₁₄	2995	481865	-	-	8	9	2.1	7295
	4	600	2	10	10	-25	80	NBR	341N31 ₁₄	2995	495870	2-22	Ex nAC IIC T3/T4	8	9	2.1	7295
	4	600	2	10	10	-25	65	NBR	341N31 ₁₄	-	495905	1-21	Ex d mb IIC T4	8	8	2.1	7295
	4	600	2	10	10	-25	80	NBR	341N3102 ₄	2995	481865	-	-	8	9	2.1	7295
	4	600	2	10	10	-40	65	PUR	341N3108 ₁	2995	481865	-	-	8	9	2.1	7295
	4	600	2	10	10	-40	65	PUR	341N3108 ₁	4270	481000	-	-	8	8	2.1	7295
	4	600	2	10	10	-40	65	PUR	341N3128	2995	481865	-	-	8	9	2.1	7295
	4	600	2	10	10	-40	65	PUR	341N3128	4270	481865	-	-	8	9	2.1	7295
	4	600	2	-	10	-25	80	FKM/NBR	341N3130 ₁₃	2995	481865	-	-	-	9	2.1	7295
	4	600	2	-	10	-25	80	FKM/NBR	341N3130 ₁₃	-	492190	1-21	Ex e mb IIC T3/T4	-	9	2.1	7295
	4	600	2	-	10	-25	80	FKM/NBR	341N3130 ₁₃	-	495905	1-21	Ex d mb IIC T4	-	8	2.1	7295
	4	600	2	-	10	-10	55	NBR	341N3190	2995	483580.01	0-20	Ex ia IIC T6	-	0.5 to 3	7.0	7349
	4	600	2	-	10	-10	75	NBR	341N3190	-	488660.01	0-20	Ex ia IIC T6	-	0.3 to 3	7.0	7349
	4	600	2	-	10	-10	75	NBR	341N3190	-	495910	0-20	Ex ia IIC T4 to T6	-	0.3 to 3	7.0	7349
	4	600	2	-	10	-25	65	NBR/PUR	341N3196	2995	482740	-	-	-	1.6	6.0/8.0	8017
	4	600	2	10	10	-25	65	NBR/PUR	341N3196	-	495900	1-21	Ex d mb IIC T4 to T6	2.5	2	6.0/8.0	8017
	4	600	2	-	10	-25	65	NBR/PUR	341N3196	-	495910	0-20	Ex ia IIC T4 to T6	-	0.3 to 3	6.0/8.0	8017
	4	600	2	-	10	-25	65	NBR/PUR	341N3196	2995	496125	2-22	Ex nAC IIC T5/T6	-	1.6	6.0/8.0	8017
	4	600	2	-	10	-25	65	NBR/PUR	341N3197 ₁	2995	482740	-	-	-	1.6	6.0/8.0	8017
	4	600	2	10	10	-25	65	NBR/PUR	341N3197 ₁	-	495900	1-21	Ex d mb IIC T4 to T6	2.5	2	6.0/8.0	8017
4	600	2	-	10	-25	65	NBR/PUR	341N3197 ₁	-	495910	0-20	Ex ia IIC T4 to T6	-	0.3 to 3	6.0/8.0	8017	
4	600	2	-	10	-25	65	NBR/PUR	341N3197 ₁	2995	496125	2-22	Ex nAC IIC T5/T6	-	1.6	6.0/8.0	8017	

Notes:

1. Avec Commande manuelle
2. Avec échappement collecté
3. Courant continu seulement. La chute de tension maximale admissible est égale à 15% de la valeur de tension nominale (DIN 19251)
4. Clapet de pilotage FKM



Dans cette page	Raccord	Orifice (mm)	Qn (l/min)	Pression Diff. Max. (bar)	Temp. Fluide (°C)	Temp. Amb. (°C)
de	1/8"-1/4"	4	600	10	-40	-25
à	1/8"-1/4"	4	600	10	80	50



Schéma 7295



Schéma 7349

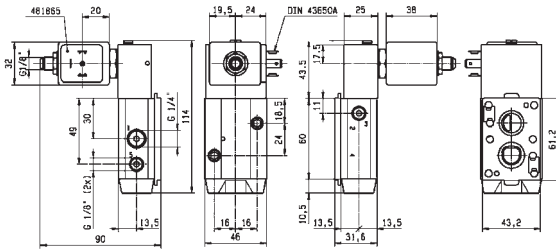

Schéma 8017

3/2-5/2

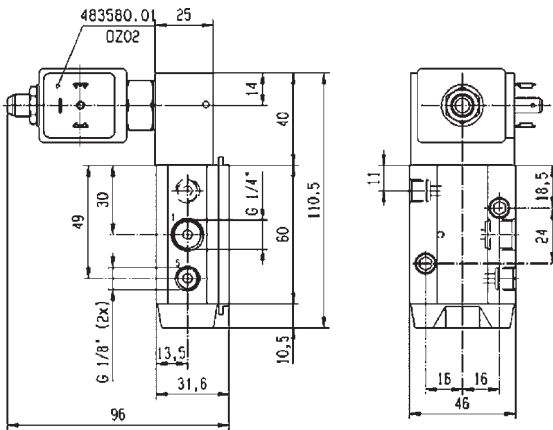
**DISTRIBUTEURS 3 & 5 VOIES POUR COMMANDE
D'ACTIONNEURS PNEUMATIQUES (NAMUR)
SERVO-COMMANDE**

ALUMINIUM ANODISÉ

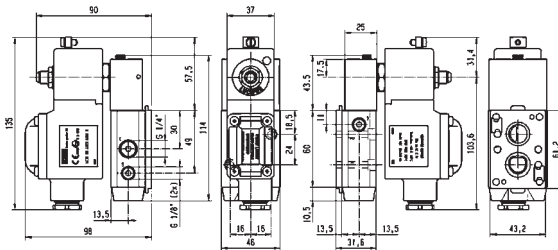
NAMUR

COMMANDE PAR SOLENOÏDE-RAPPEL PAR RESSORT

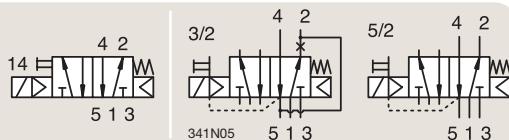

Raccord BSP	Orifice Ø 1	Facteur d'Écoulement Qn l/min	Pression Différentielle		Temp. Fluide		Joint	Electrovannes PARKER LUCIFER®			Zone ATEX	Mode de Protection	Puissance		Groupe Électrique	N° Schéma	
			Min bar	Max AC bar	DC bar	Min °C		Max °C	Ref. Valve	Ref. Boîtier			Ref. Bobine	AC W			DC W
1/8"- 1/4"	8	1400	2	-	10	-25	55	NBR	341N3290	2995	483580.01	0-20	Ex ia IIC T6	-	0.5 to 3	7.0	7350
	8	1400	2	-	10	-25	75	NBR	341N3290	-	488660.01	0-20	Ex ia IIC T6	-	0.3 to 3	7.0	7350
	8	1400	2	-	10	-25	75	NBR	341N3290	-	495910	0-20	Ex ia IIC T4 to T6	-	0.3 to 3	7.0	7350
	8	1400	2	-	10	-20	80	NBR/PUR	341N3296	2995	482740	-	-	-	1.6	6.0/8.0	8029
	8	1400	2	10	10	-20	80	NBR/PUR	341N3296	-	495900	1-21	Ex d mb IIC T4 to T6	2.5	2	6.0/8.0	8029
	8	1400	2	-	10	-20	80	NBR/PUR	341N3296	-	495910	0-20	Ex ia IIC T4 to T6	-	0.3 to 3	6.0/8.0	8029
	8	1400	2	-	10	-20	80	NBR/PUR	341N3296	2995	496125	2-22	Ex nAC IIC T5/T6	-	1.6	6.0/8.0	8029
	8	1400	2	-	10	-20	80	NBR/PUR	341N3297 ₁	2995	482740	-	-	-	1.6	6.0/8.0	8029
	8	1400	2	10	10	-20	80	NBR/PUR	341N3297 ₁	-	495900	1-21	Ex d mb IIC T4 to T6	2.5	2	6.0/8.0	8029
	8	1400	2	-	10	-20	80	NBR/PUR	341N3297 ₁	-	495910	0-20	Ex ia IIC T4 to T6	-	0.3 to 3	6.0/8.0	8029
1/4"	7	1250	2.5	10	10	-10	50	NBR	341N05 ₁	-	496131	-	-	3	3	1.2	8162
	7	1250	2.5	10	10	-10	50	NBR	341N05 ₁	-	496482	-	-	3	3	1.2	8162
	7	1250	2.5	10	10	-10	50	NBR	341N05 ₁	-	496637	22	Ex tD A22 IP65 - T95°C	3	3	1.2	8162

Notes:

1. Avec Commande manuelle

3/2-5/2

DISTRIBUTEURS 3 & 5 VOIES POUR COMMANDE D'ACTIONNEURS PNEUMATIQUES (NAMUR) SERVO-COMMANDE

ALUMINIUM ANODISÉ
NAMUR

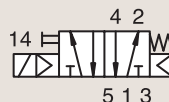

COMMANDE PAR SOLENOÏDE-RAPPEL PAR RESSORT

Raccord BSP	Orifice Ø 1 mm	Facteur d'Écoulement Qn l/min	Pression Différentielle			Temp. Fluide		Joint	Electrovannes PARKER LUCIFER®			Zone ATEX	Mode de Protection	Puissance		Groupe Electrique	N° Schéma
			Min bar	Max AC bar	Max DC bar	Min °C	Max °C		Ref. Valve	Ref. Boîtier	Ref. Bobine			AC W	DC W		
1/4"	7	1200	2.5	10	10	-10	50	NBR	341N0502	-	496131	-	-	3	3	1.2	8253
	7	1200	2.5	10	10	-10	50	NBR	341N0502	-	496482	-	-	3	3	1.2	8253
	7	1200	2.5	10	10	-10	50	NBR	341N35 ₁₃	2995	481865	-	-	8	9	2.1	8213
	7	1200	2.5	10	10	-10	50	NBR	341N35 ₁₃	2995	495870	2-22	Ex nAC IIC T3/T4	8	9	2.1	8213
	7	1200	2.5	10	10	-10	50	NBR	341N35 ₁₃	-	495905	1-21	Ex d mb IIC T4	8	8	2.1	8213
	7	1200	2.5	10	10	-10	50	NBR	341N3502 ₃	2995	481865	-	-	8	9	2.1	8254
	7	1200	2.5	10	10	-10	50	NBR	341N3502 ₃	4270	481000	-	-	8	8	2.1	8254
	8	1400	2	10	10	-25	80	NBR	341N02 ₁₂	8993	488980	-	-	2	2.5	1.1	7313

Notes:

1. Avec Commande manuelle
2. Avec échappement collecté
3. Clapet de pilotage en FKM



Schéma 7313



Dans cette page	Raccord	Orifice (mm)	Qn (l/min)	Pression Diff. Max. (bar)	Temp. Fluide (°C)	Temp. Amb. (°C)
de	1/4"	7	1200	10	-25	-25
à	1/4"	8	1400	10	80	50

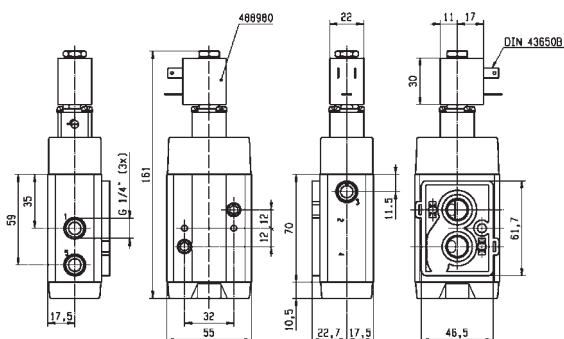

Schéma 8253



Schéma 8213

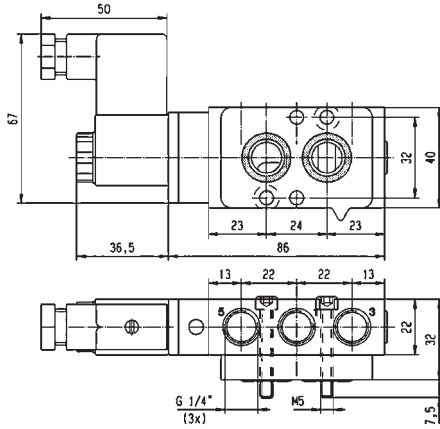

Schéma 8254

3/2-5/2

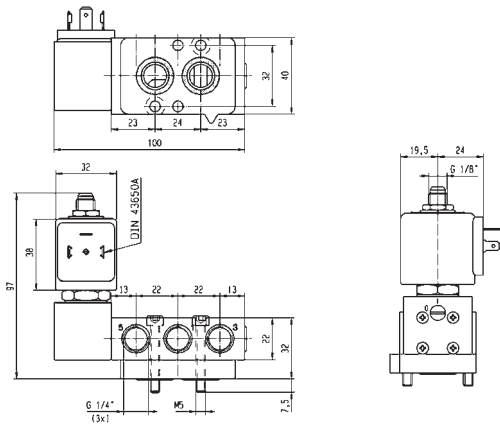
**DISTRIBUTEURS 3 & 5 VOIES POUR COMMANDE
D'ACTIONNEURS PNEUMATIQUES (NAMUR)
SERVO-COMMANDE**

ALUMINIUM ANODISÉ

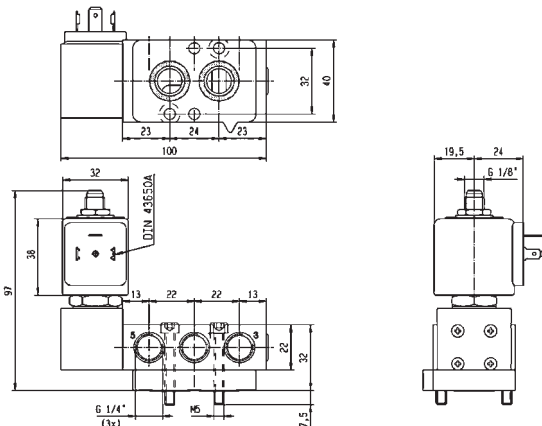
NAMUR

COMMANDE PAR SOLENOÏDE-RAPPEL PAR RESSORT

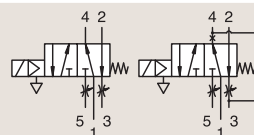

Raccord BSP	Orifice Ø 1 mm	Facteur d'Écoulement Qn l/min	Pression Différentielle			Temp. Fluide		Joint	Electrovannes PARKER LUCIFER®			Zone ATEX	Mode de Protection	Puissance		Groupe Electrique	N° Schéma
			Min	Max	Max	Min	Max		Ref. Valve	Ref. Boîtier	Ref. Bobine			AC W	DC W		
1/4"	8	1400	2	10	10	-25	80	NBR	341N12 ₁₂	8993	488980	-	-	2	2.5	1.1	7312
	8	1400	2	10	10	-25	80	NBR	341N22 ₁₃	2995	481865	-	-	8	9	2.1	7318
	8	1400	2	10	10	-25	80	NBR	341N22 ₁₃	4270	481000	-	-	8	8	2.1	7318
	8	1400	2	10	10	-25	80	NBR	341N32 ₁₃	2995	481865	-	-	8	9	2.1	7317
	8	1400	2	10	10	-25	80	NBR	341N32 ₁₃	2995	495870	2-22	Ex nAC IIC T3/T4	8	9	2.1	7317
	8	1400	2	10	10	-25	80	NBR	341N32 ₁₃	-	495905	1-21	Ex d mb IIC T4	8	8	2.1	7317
	8	1400	2	10	10	-25	80	NBR	341N3202 ₃	2995	481865	-	-	8	9	2.1	7317
	8	1400	2	10	10	-25	80	NBR	341N3202 ₃	2995	495870	2-22	Ex nAC IIC T3/T4	8	9	2.1	7317
8	1400	2	10	10	-25	80	NBR	341N3202 ₃	-	495905	1-21	Ex d mb IIC T4	8	8	2.1	7317	

Notes:

1. Avec Commande manuelle
2. Avec échappement collecté
3. Clapet du pilotage en FKM



Dans cette page	Raccord	Orifice (mm)	Qn (l/min)	Pression Diff. Max. (bar)	Temp. Fluide (°C)	Temp. Amb. (°C)
de	1/4"	8	1400	10	-25	-25
à	1/4"	8	1400	10	80	50



Schéma 7312



Schéma 7318

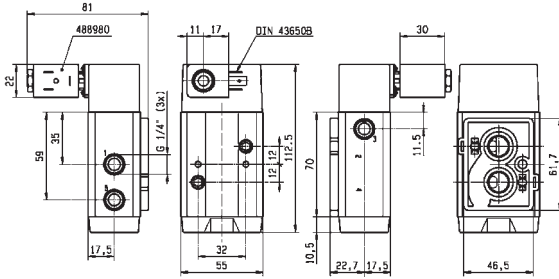

Schéma 7317

5/2

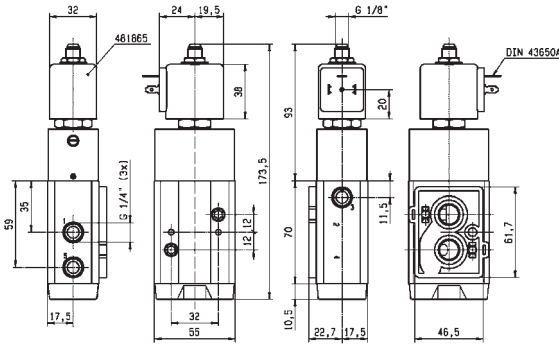
DISTRIBUTEURS 3 & 5 VOIES POUR COMMANDE D'ACTIONNEURS PNEUMATIQUES (NAMUR) SERVO-COMMANDE

ALUMINIUM ANODISÉ

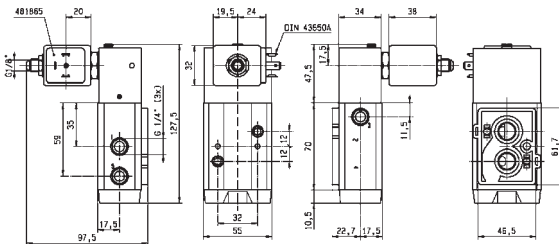
NAMUR

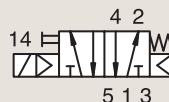

COMMANDE PAR SOLENOÏDE-RAPPEL PAR RESSORT

Raccord BSP	Orifice Ø 1 mm	Facteur d'Écoulement Qn l/min	Pression Différentielle		Temp. Fluide		Joint	Electrovannes PARKER LUCIFER®			Zone ATEX	Mode de Protection	Puissance		Groupe Electrique	N° Schéma	
			Min bar	Max AC bar	DC bar	Min °C		Max °C	Ref. Valve	Ref. Boîtier			Ref. Bobine	AC W			DC W
1/4"	7	1250	2.5	10	10	-10	50	NBR	341N03 ₁	-	496131	-	-	3	3	1.2	8063
	7	1250	2.5	10	10	-10	50	NBR	341N03 ₁	-	496482	-	-	3	3	1.2	8063
	7	1250	2.5	10	10	-10	50	NBR	341N03 ₁	-	496637	22	Ex tD A22 IP65 - T95°C	3	3	1.2	8063
1/2"	12	3000	2	10	10	-10	50	NBR	341N04 ₁	-	496131	-	-	3	3	1.2	8065
	12	3000	2	10	10	-10	50	NBR	341N04 ₁	-	496482	-	-	3	3	1.2	8065
	12	3000	2	10	10	-10	50	NBR	341N04 ₁	-	496637	22	Ex tD A22 IP65 - T95°C	3	3	1.2	8065
	12	3000	2.5	10	10	-10	50	NBR	341N34 ₁₂	2995	481865	-	-	8	9	2.1	8211
	12	3000	2.5	10	10	-10	50	NBR	341N34 ₁₂	2995	495870	2-22	Ex nAC IIC T3/T4	8	9	2.1	8211
	12	3000	2.5	10	10	-10	50	NBR	341N34 ₁₂	-	495905	1-21	Ex d mb IIC T4	8	8	2.1	8211

Notes:

1. Avec Commande manuelle
2. Clapet du pilotage en FKM



Dans cette page	Raccord	Orifice (mm)	Qn (l/min)	Pression Diff. Max. (bar)	Temp. Fluide (°C)	Temp. Amb. (°C)
de	1/4"	7	1250	10	-10	-10
à	1/2"	12	3000	10	50	50



Schéma 8063



Schéma 8065

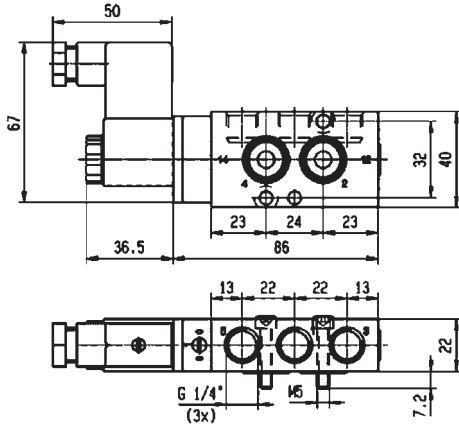

Schéma 8211

5/2

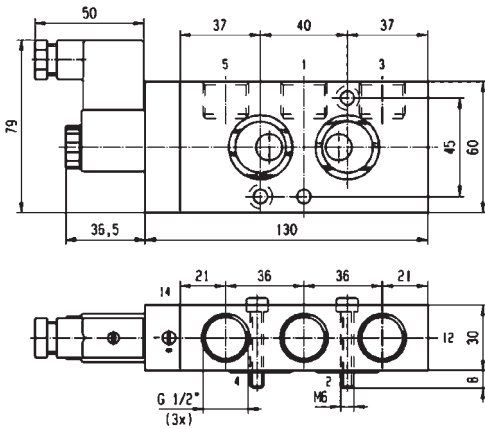
DISTRIBUTEURS 3 & 5 VOIES POUR COMMANDE D'ACTIONNEURS PNEUMATIQUES (NAMUR) SERVO-COMMANDE

ALUMINIUM ANODISÉ
NAMUR

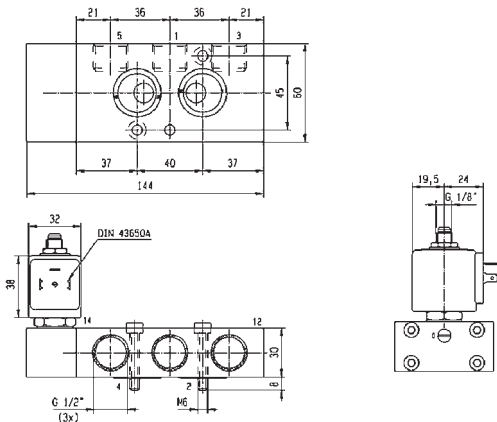
COMMANDE PAR 2 SOLENOIDES

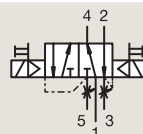

Raccord BSP	Orifice Ø 1 mm	Facteur d'Écoulement Qn l/min	Pression Différentielle			Temp. Fluide		Joint	Electrovannes PARKER LUCIFER®			Zone ATEX	Mode de Protection	Puissance		Groupe Electrique	N° Schéma
			Min bar	Max AC bar	Max DC bar	Min °C	Max °C		Ref. Valve	Ref. Boîtier	Ref. Bobine			AC W	DC W		
1/8"- 1/4"	4	400	2	10	10	-25	50	NBR	347N11 ₁₂₃	-	482606	1-21	Ex mb IIC T4/T5	2	2.5	1.1	7305
	4	400	2	10	10	-25	80	NBR	347N11 ₁₂₃	8993	488980	-	-	2	2.5	1.1	7305
	4	400	2	10	10	-25	80	NBR	347N31 ₁₃	2995	481865	-	-	8	9	2.1	7297
	4	400	2	10	10	-25	80	NBR	347N31 ₁₃	2995	495870	2-22	Ex nAC IIC T3/T4	8	9	2.1	7297
	4	400	2	10	10	-25	80	NBR	347N31 ₁₃	-	495905	1-21	Ex d mb IIC T4	8	8	2.1	7297
	4	400	2	-	10	-25	55	NBR	347N3190 ₃	2995	483580.01	0-20	Ex ia IIC T6	-	0.5 to 3	7.0	8141
	4	400	2	-	10	-25	65	NBR/PUR	347N3197 ₁	2995	482740	-	-	-	1.6	3.0/6.0/8.0	7297
	4	400	2	10	10	-25	65	NBR/FKM	347N3197 ₁	-	495900	1-21	Ex d mb IIC T4 to T6	2.5	2	3.0/6.0/8.0	7297
	4	400	2	-	10	-25	65	NBR/PUR	347N3197 ₁	-	495910	0-20	Ex ia IIC T4 to T6	-	0.3 to 3	3.0/6.0/8.0	7297
	4	400	2	-	10	-25	65	NBR/PUR	347N3197 ₁	2995	496125	2-22	Ex nAC IIC T5/T6	-	1.6	3.0/6.0/8.0	7297

Notes:

1. Avec commande manuelle
2. Avec échappement collecté
3. Clapet du pilotage en FKM



Dans cette page	Raccord	Orifice (mm)	Qn (l/min)	Pression Diff. Max. (bar)	Temp. Fluide (°C)	Temp. Amb. (°C)
de	1/8"-1/4"	4	400	10	-25	-25
à	1/8"-1/4"	4	400	10	80	50



Schéma 7305



Schéma 7297

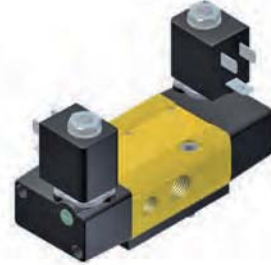
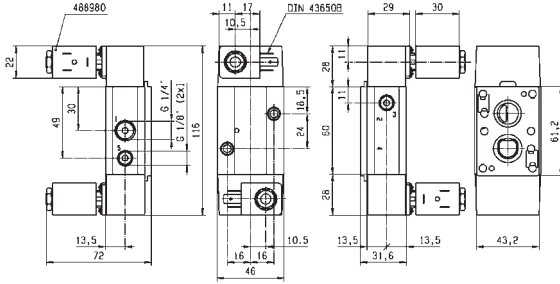

Schéma 8141

5/2

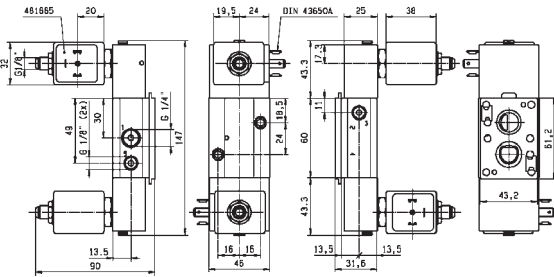
DISTRIBUTEURS 3 & 5 VOIES POUR COMMANDE D'ACTIONNEURS PNEUMATIQUES (NAMUR) SERVO-COMMANDE

ALUMINIUM ANODISÉ

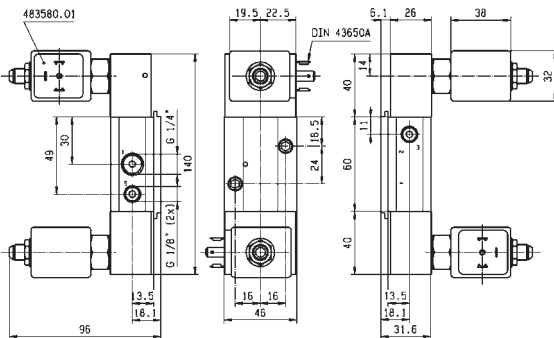
NAMUR

COMMANDE PAR 2 SOLENOIDES

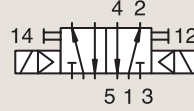

Raccord BSP	Orifice Ø 1	Facteur d'Écoulement Qn l/min	Pression Différentielle		Temp. Fluide		Joint	Electrovannes PARKER LUCIFER®			Zone ATEX	Mode de Protection	Puissance		Groupe Electrique	N° Schéma
			Min bar	Max AC bar DC bar	Min °C	Max °C		Ref. Valve	Ref. Boîtier	Ref. Bobine			AC W	DC W		
1/4"	7	1250	1.5	10 10	-10	50	NBR	347N03 ₁	-	496131	-	-	3	3	1.2	8057
	7	1250	1.5	10 10	-10	50	NBR	347N03 ₁	-	496482	-	-	3	3	1.2	8057
	7	1250	1.5	10 10	-10	50	NBR	347N03 ₁	-	496637	22	Ex tD A22 IP65 - T95°C	3	3	1.2	8057
	7	1250	2.5	10 10	-10	120	NBR	347N33 ₁₃	2995	481865	-	-	8	9	2.1	8209
	7	1250	2.5	10 10	-10	120	NBR	347N33 ₁₃	2995	495870	2-22	Ex nAC IIC T3/T4	8	9	2.1	8209
	7	1250	2.5	10 10	-10	120	NBR	347N33 ₁₃	-	495905	1-21	Ex d mb IIC T4	8	8	2.1	8209
	8	1400	2	10 10	-10	65	NBR	347N12 ₁₂	-	482606	1-21	Ex mb IIC T4/T5	2	2.5	1.1	7315
	8	1400	2	10 10	-25	80	NBR	347N12 ₁₂	8993	488980	-	-	2	2.5	1.1	7315
	8	1400	2	10 10	-25	80	NBR	347N32 ₁₃	2995	481865	-	-	8	9	2.1	7320
	8	1400	2	10 10	-25	80	NBR	347N32 ₁₃	2995	495870	2-22	Ex nAC IIC T3/T4	8	9	2.1	7320
8	1400	2	10 10	-25	80	NBR	347N32 ₁₃	-	495905	1-21	Ex d mb IIC T4	8	8	2.1	7320	

Notes:

- 1. Avec Commande manuelle
- 2. Avec échappement collecté
- 3. Clapet du pilote en FKM



Schéma 7320



Dans cette page	Raccord	Orifice (mm)	Qn (l/min)	Pression Diff. Max. (bar)	Temp. Fluide (°C)	Temp. Amb. (°C)
de	1/4"	7	1250	10	-25	-25
à	1/4"	8	1400	10	120	50

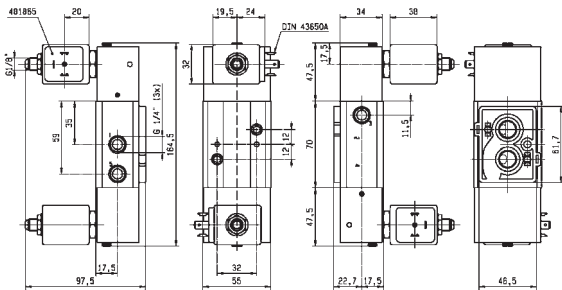

Schéma 8057



Schéma 8209

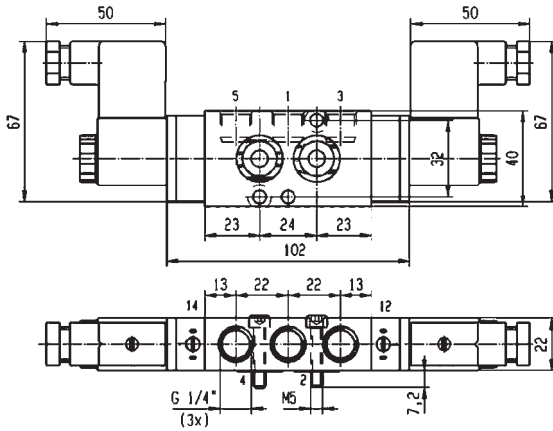

Schéma 7315

5/2

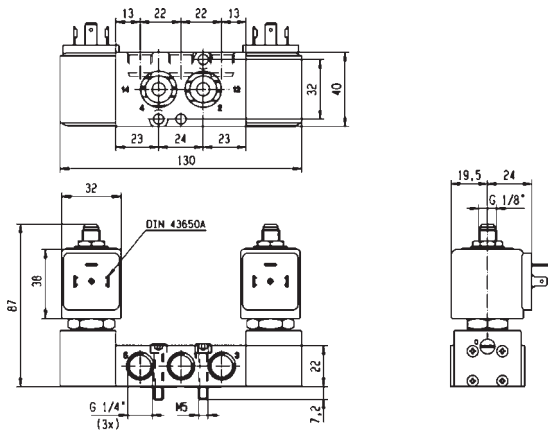
DISTRIBUTEURS 3 & 5 VOIES POUR COMMANDE D'ACTIONNEURS PNEUMATIQUES (NAMUR) SERVO-COMMANDE

ALUMINIUM ANODISÉ

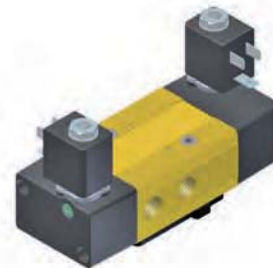
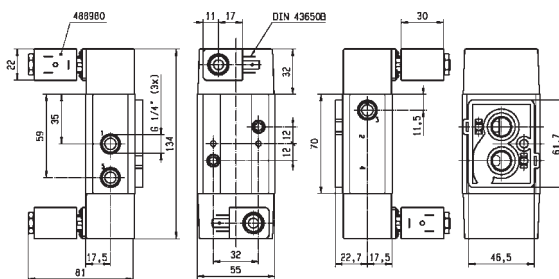
NAMUR

COMMANDE PAR 2 SOLENOIDES

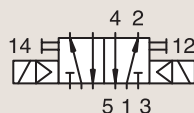

Raccord BSP	Orifice Ø 1 mm	Facteur d'Écoulement Qn l/min	Pression Différentielle			Temp. Fluide		Joint	Electrovannes PARKER LUCIFER®			Zone ATEX	Mode de Protection	Puissance		Groupe Electrique	N° Schéma
			Min bar	Max AC bar	Max DC bar	Min °C	Max °C		Ref. Valve	Ref. Boîtier	Ref. Bobine			AC W	DC W		
1/2"	12	3000	1.5	10	10	-10	50	NBR	347N04 ₁	-	496131	-	-	3	3	1.2	8154
	12	3000	1.5	10	10	-10	50	NBR	347N04 ₁	-	496482	-	-	3	3	1.2	8154
	12	3000	1.5	10	10	-10	50	NBR	347N04 ₁	-	496637	22	Ex tD A22 IP65 - T95°C	3	3	1.2	8154
	12	3000	2.5	10	10	-10	120	NBR	347N34 ₁₂	2995	481865	-	-	8	9	2.1	8212
	12	3000	2.5	10	10	-10	120	NBR	347N34 ₁₂	2995	495870	2-22	Ex nAC IIC T3/T4	8	9	2.1	8212
	12	3000	2.5	10	10	-10	120	NBR	347N34 ₁₂	-	495905	1-21	Ex d mb IIC T4	8	8	2.1	8212

Notes:

1. Avec Commande manuelle
2. Clapet de pilote en FKM



Dans cette page	Raccord	Orifice (mm)	Qn (l/min)	Pression Diff. Max. (bar)	Temp. Fluide (°C)	Temp. Amb. (°C)
de	1/2"	12	3000	10	-10	-10
à	1/2"	12	3000	10	120	50



Schéma 8154



Schéma 8212

5/3

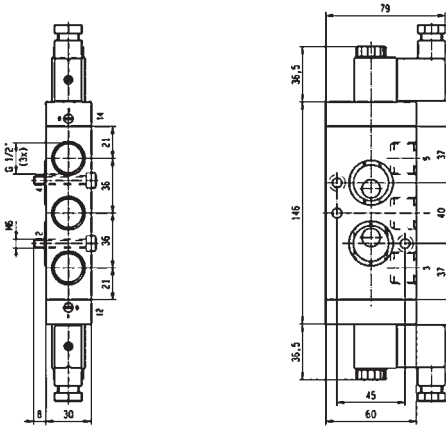
DISTRIBUTEURS 3 & 5 VOIES POUR COMMANDE D'ACTIONNEURS PNEUMATIQUES (NAMUR) SERVO-COMMANDE

ALUMINIUM ANODISÉ
NAMUR

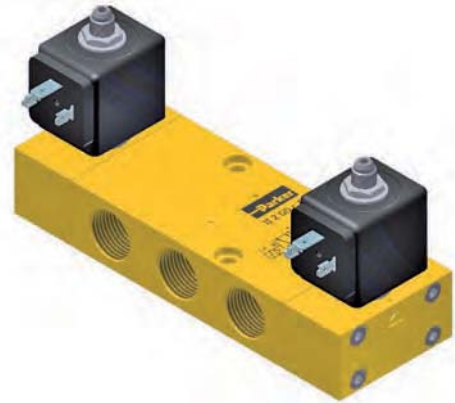
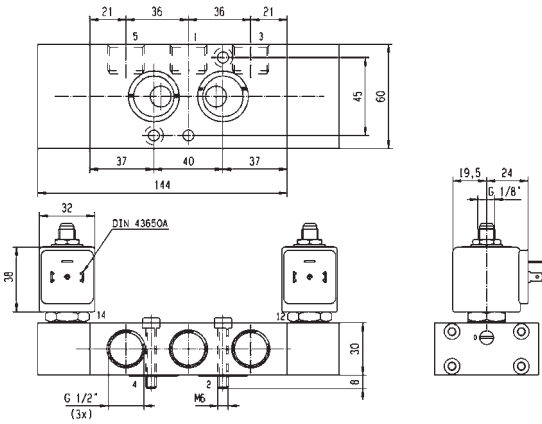
W1 FERMÉE EN POSITION CENTRALE

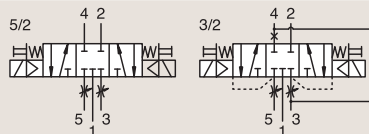

Raccord BSP	Orifice Ø 1	Facteur d'Écoulement Qn l/min	Pression Différentielle		Temp. Fluide		Joint	Electrovannes PARKER LUCIFER®			Zone ATEX	Mode de Protection	Puissance		Groupe Électrique	N° Schéma	
			Min bar	Max DC bar	Min °C	Max °C		Ref. Valve	Ref. Boîtier	Ref. Bobine			AC W	DC W			
1/8"- 1/4"	4	400	2	10	10	-25	80	NBR	342N11 ₁₂	-	482606	1-21	Ex mb IIC T4/T5	2	2.5	1.1	7305
	4	400	2	10	10	-25	80	NBR	342N11 ₁₂	8993	488980	-	-	2	2.5	1.1	7305
1/4"	4	400	2	-	10	-10	65	NBR	342N3197 ₁	-	495910	0-20	Ex ia IIC T4 to T6	-	0.3 to 3	6.0/8.0	7297
	7	1250	3	10	10	-10	50	NBR	342N03 ₁	-	496131	-	-	3	3	1.2	8057
	7	1250	3	10	10	-10	50	NBR	342N03 ₁	-	496482	-	-	3	3	1.2	8057
	7	1250	3	10	10	-10	50	NBR	342N03 ₁	-	496637	22	Ex tD A22 IP65 - T95°C	3	3	1.2	8057
	7	1250	2.5	10	10	-10	120	NBR	342N33 ₁	2995	481865	-	-	8	9	2.1	8209
	7	1250	2.5	10	10	-10	120	NBR	342N33 ₁	2995	495870	2-22	Ex nAC IIC T3/T4	8	9	2.1	8209
	7	1250	2.5	10	10	-10	120	NBR	342N33 ₁	-	495905	1-21	Ex d mb IIC T4	8	8	2.1	8209

Notes:

- 1. Avec Commande manuelle
- 2. Avec échappement collecté



Schéma 8209



Dans cette page	Raccord	Orifice (mm)	Qn (l/min)	Pression Diff. Max. (bar)	Temp. Fluide (°C)	Temp. Amb. (°C)
From	1/8"-1/4"	4	400	10	-25	-25
To	1/4"	7	1250	10	120	50

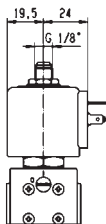
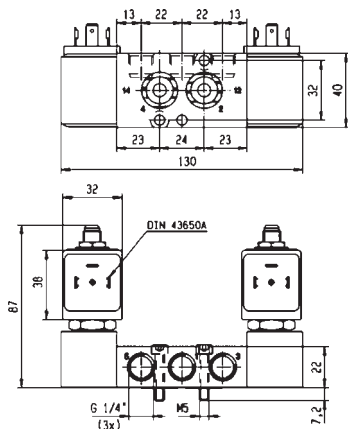

Schéma 7305



Schéma 7297

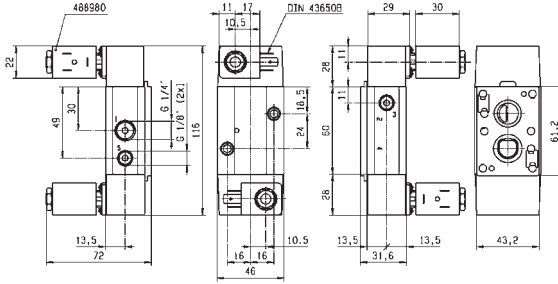

Schéma 8057

5/3

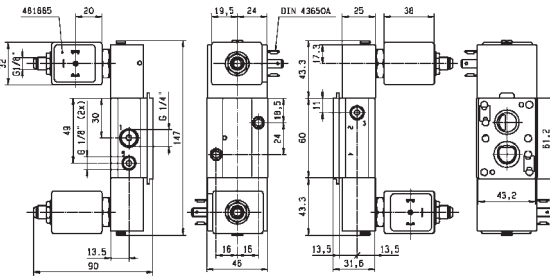
DISTRIBUTEURS 3 & 5 VOIES POUR COMMANDE D'ACTIONNEURS PNEUMATIQUES (NAMUR) SERVO-COMMANDE

ALUMINIUM ANODISÉ

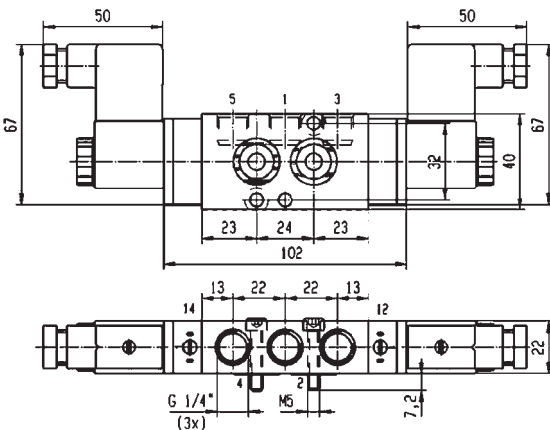
NAMUR

W3 À L'ÉCHAPPEMENT EN POSITION CENTRALE



Raccord BSP	Orifice Ø 1 mm	Facteur d'Écoulement Qn l/min	Pression Différentielle		Temp. Fluide		Joint	Electrovannes PARKER LUCIFER®			Zone ATEX	Mode de Protection	Puissance		Groupe Electrique	N° Schéma
			Min bar	Max AC DC bar	Min °C	Max °C		Ref. Valve	Ref. Boîtier	Ref. Bobine			AC W	DC W		
1/4"	7	1250	3	10 10	-10 50	NBR	343N03 ₁	-	496131	-	-	3	3	1.2	8057	
	7	1250	3	10 10	-10 50	NBR	343N03 ₁	-	496482	-	-	3	3	1.2	8057	
	7	1250	3	10 10	-10 50	NBR	343N03 ₁	-	496637	22	Ex tD A22 IP65 - T95°C	3	3	1.2	8057	

Notes:

1. Avec Commande manuelle



Dans cette page	Raccord	Orifice (mm)	Qn (l/min)	Pression Diff. Max. (bar)	Temp. Fluide (°C)	Temp. Amb. (°C)
de	1/4"	7	1250	10	-10	-10
à	1/4"	7	1250	10	50	50



Schéma 8057

3/2-5/2

**DISTRIBUTEURS 3 & 5 VOIES POUR COMMANDE
D'ACTIONNEURS PNEUMATIQUES (NAMUR)
SERVO-COMMANDE**

ALUMINIUM ANODISÉ

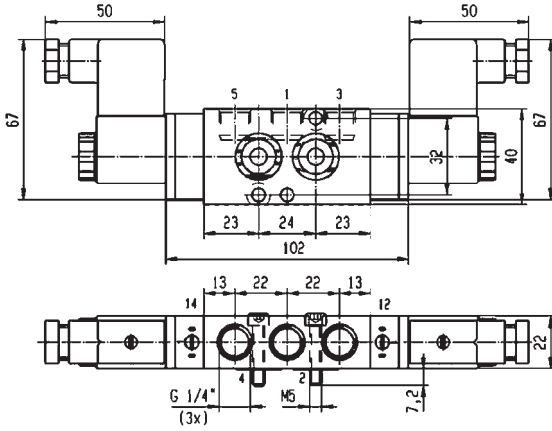
NAMUR

CONTROLÉE PAR IMPULSION ELECTRIQUE

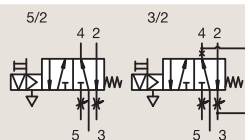

Raccord	Orifice Ø	Facteur d'Écoulement	Pression Différentielle		Temp. Fluide		Joint	Electrovannes PARKER LUCIFER®			Zone ATEX	Mode de Protection	Puissance		Groupe Electrique	N° Schéma	
			Min	Max	Min	Max		Ref. Valve	Ref. Boîtier	Ref. Bobine			AC W	DC W			
BSP	1	Qn l/min	bar	AC bar	DC bar	°C	°C										
1/8"- 1/4"	4	600	2	-	10	-25	80	NBR	345N31 ₁₂	4269	485400	-	-	-	13	4.0	7295

Notes:

- 1.Avec Commande manuelle
- 2.Joint du clapet de pilotage en FKM

ALUMINIUM ANODISÉ

NAMUR

COMMANDE PAR SOLENOÏDE-RAPPEL PAR RESSORT

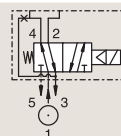

Raccord	Orifice Ø	Facteur d'Écoulement	Pression Différentielle		Temp. Fluide		Joint	Electrovannes PARKER LUCIFER®			Zone ATEX	Mode de Protection	Puissance		Groupe Electrique	N° Schéma	
			Min	Max	Min	Max		Ref. Valve	Ref. Boîtier	Ref. Bobine			AC W	DC W			
BSP	1	Qn l/min	bar	AC bar	DC bar	°C	°C										
1/8"- 1/4"	4	355	1	10	10	-10	75	NBR	341L9504 ₁₂	-	482605	1-21	Ex mb IIC T4	4	5	1.1	7009
	4	355	1	10	10	-10	75	NBR	341L9504 ₁₂	-	482606	1-21	Ex mb IIC T4/T5	2	2.5	1.1	7009
	4	355	1	10	10	-10	75	NBR	341L9504 ₁₂	8993	488980	-	-	2	2.5	1.1	7009
	4	355	1	10	10	-10	75	NBR	341L9504 ₁₂	8993	495865	2-22	Ex nAC IIC T5	2	2.5	1.1	7009
	4	355	1	10	10	-10	75	NBR	341L9534 ₁₂	2995	481865	-	-	8	9	2.1/7.0	3990
	4	355	1	10	10	-10	75	NBR	341L9534 ₁₂	2995	495870	2-22	Ex nAC IIC T3/T4	8	9	2.1/7.0	3990
	4	355	1	10	10	-10	75	NBR	341L9534 ₁₂	-	495905	1-21	Ex d mb IIC T4	8	8	2.1/7.0	3990

Notes:

- 1.Avec Commande manuelle
- 2.Joint du clapet de pilotage en FKM



Dans cette page	Raccord	Orifice (mm)	Qn (l/min)	Pression Diff. Max. (bar)	Temp. Fluide (°C)	Temp. Amb. (°C)
de	1/8"-1/4"	4	355	10	-25	-25
à	1/8"-1/4"	4	600	10	80	50



Schéma 7295



Weight : 310 gr

Schéma 7009

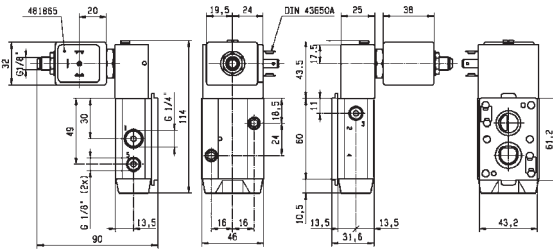
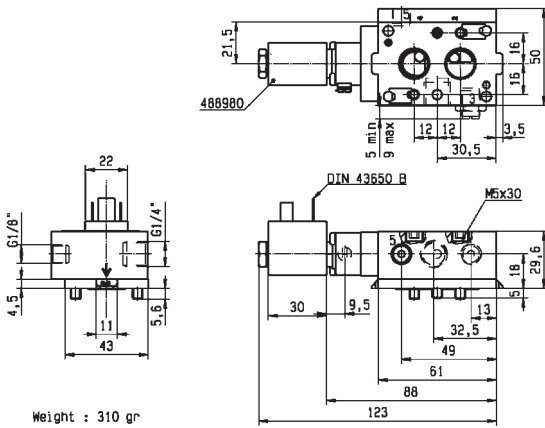

Schéma 3990

3/2-5/2

**DISTRIBUTEURS 3 & 5 VOIES POUR COMMANDE
D'ACTIONNEURS PNEUMATIQUES (NAMUR)
SERVO-COMMANDE**

**ALUMINIUM ANODISÉ
NAMUR**

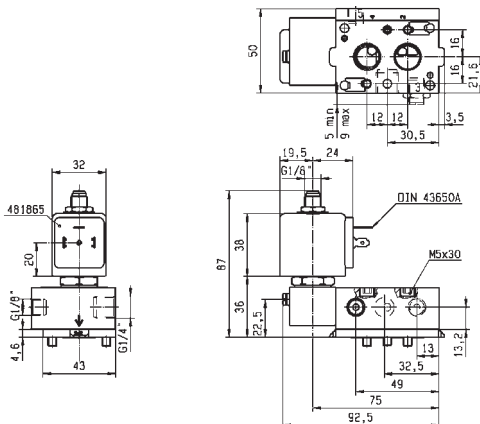
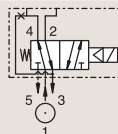

COMMANDE PAR SOLENOÏDE-RAPPEL PAR RESSORT

Raccord BSP	Orifice Ø 1 mm	Facteur d'Écoulement Qn l/min	Pression Différentielle			Temp. Fluide		Joint	Electrovannes PARKER LUCIFER®			Zone ATEX	Mode de Protection	Puissance		Groupe Electrique	N° Schéma
			Min bar	Max AC bar	Max DC bar	Min °C	Max °C		Ref. Valve	Ref. Boîtier	Ref. Bobine			AC W	DC W		
1/8"- 1/4"	4	355	2	-	10	-10	55	NBR	341L9594 _{1,2}	2995	483580.01	0-20	Ex ia IIC T6	-	0.5 to 3	7.0	3992
	4	355	1	-	10	-10	75	NBR	341L9594 _{1,2}	-	495910	0-20	Ex ia IIC T4 to T6	-	0.3 to 3	7.0	3992
	4	355	2	-	10	-10	75	NBR/PUR	341L9597 ₁	2995	482740	-	-	-	1.6	6.0/8.0	8025
	4	355	2	10	10	-10	75	NBR/PUR	341L9597 ₁	-	495900	1-21	Ex d mb IIC T4 to T6	2.5	2	6.0/8.0	8025
	4	355	2	-	10	-10	75	NBR/PUR	341L9597 ₁	-	495910	0-20	Ex ia IIC T4 to T6	-	0.3 to 3	6.0/8.0	8025
	4	355	2	-	10	-10	75	NBR/PUR	341L9597 ₁	2995	496125	2-22	Ex nAC IIC T5/T6	-	1.6	6.0/8.0	8025
	4	355	2	-	10	-25	55	NBR/PUR	341L9598 ₁	2995	483580.01	0-20	Ex ia IIC T6	-	0.5 to 3	7.0	3992

Notes:

- 1. Avec Commande manuelle
- 2. Joint du clapet de pilotage en FKM



Dans cette page	Raccord	Orifice (mm)	Qn (l/min)	Pression Diff. Max. (bar)	Temp. Fluide (°C)	Temp. Amb. (°C)
de	1/8"-1/4"	4	355	10	-25	-25
à	1/8"-1/4"	4	355	10	75	50



Schéma 3992



Schéma 8025

5/3

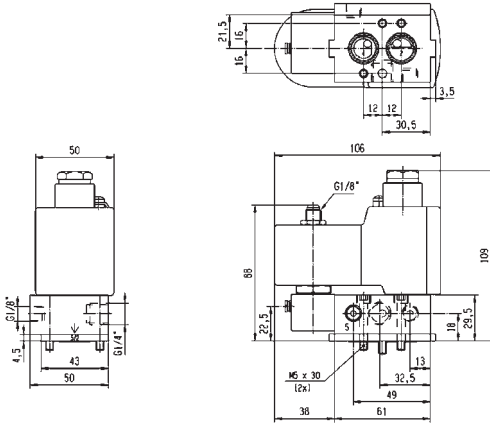
DISTRIBUTEURS 3 & 5 VOIES POUR COMMANDE D'ACTIONNEURS PNEUMATIQUES (NAMUR) PILOTAGE EXTERNE

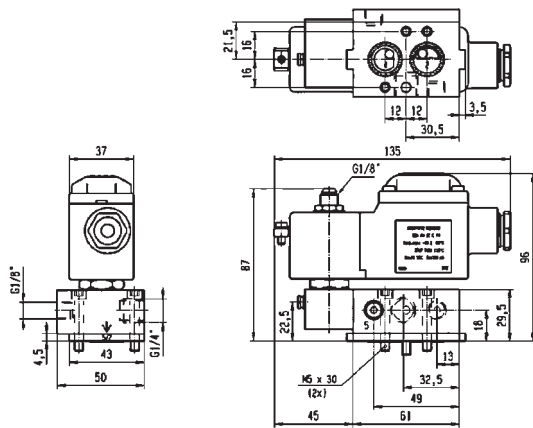

Process

ALUMINIUM ANODISÉ NAMUR

COMMANDE PAR AIR-RAPPEL PAR RESSORT

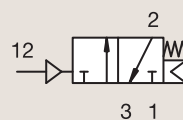

Raccord	Orifice Ø	Facteur d'Écoulement	Pression Différentielle			Temp. Fluide		Joint	Electrovannes PARKER LUCIFER®			Zone ATEX	Mode de Protection	Puissance		Groupe Electrique	N° Schéma
			Min	Max		Min	Max		Ref. Valve	Ref. Boîtier	Ref. Bobine			AC W	DC W		
BSP	1 mm	Qn l/min	bar	AC bar	DC bar	Min °C	Max °C										
1/4"	7	1250	2.5	10	10	-10	50	NBR	531N03	-	-	-	-	-	-	-	8058
1/2"	12	3000	2.5	10	10	-10	50	NBR	531N04	-	-	-	-	-	-	-	8061



Dans cette page	Raccord	Orifice (mm)	Qn (l/min)	Pression Diff. Max. (bar)	Temp. Fluide (°C)	Temp. Amb. (°C)
de	1/4"	7	1250	10	-10	-10
à	1/2"	12	3000	10	50	50



Schéma 8058



Schéma 8061

3/2-5/2

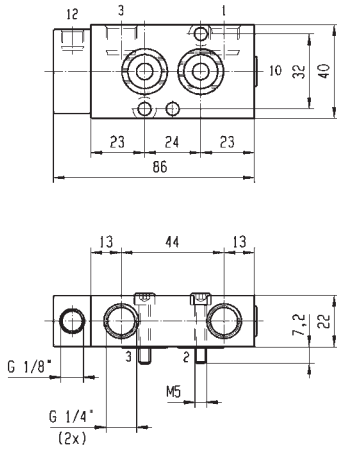
**DISTRIBUTEURS 3 & 5 VOIES POUR COMMANDE
D'ACTIONNEURS PNEUMATIQUES (NAMUR)
PILOTAGE EXTERNE**

ALUMINIUM ANODISÉ

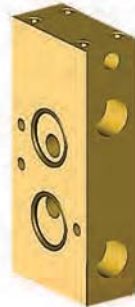
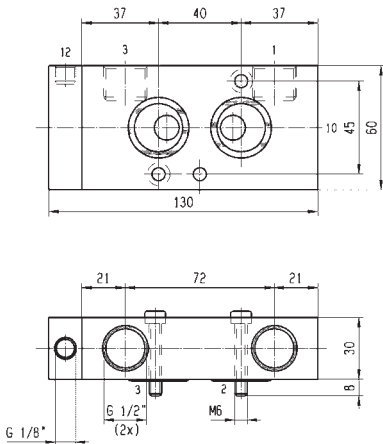
NAMUR

COMMANDE PAR AIR-RAPPEL PAR RESSORT

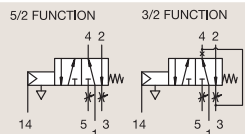

Raccord	Orifice Ø	Facteur d'Écoulement	Pression Différentielle			Temp. Fluide		Joint	Electrovannes PARKER LUCIFER®			Zone ATEX	Mode de Protection	Puissance		Groupe Electrique	N° Schéma
			Min	Max		Min	Max		Ref. Valve	Ref. Boîtier	Ref. Bobine			AC W	DC W		
BSP	1	Qn l/min	bar	AC	DC	°C	°C										
	mm			bar	bar												
1/8"- 1/4"	4	600	2	10	10	-25	80	NBR	541N01	-	-	-	-	-	-	-	7309
	4	600	2	10	10	-40	50	NBR	541N0108	-	-	-	-	-	-	-	7309



Dans cette page	Raccord	Orifice (mm)	Qn (l/min)	Pression Diff. Max. (bar)	Temp. Fluide (°C)	Temp. Amb. (°C)
de	1/8"-1/4"	4	600	10	-40	-40
à	1/8"-1/4"	4	600	10	80	50



Schéma 7309

5/2

DISTRIBUTEURS 3 & 5 VOIES POUR COMMANDE D'ACTIONNEURS PNEUMATIQUES (NAMUR) PILOTAGE EXTERNE

ALUMINIUM ANODISÉ

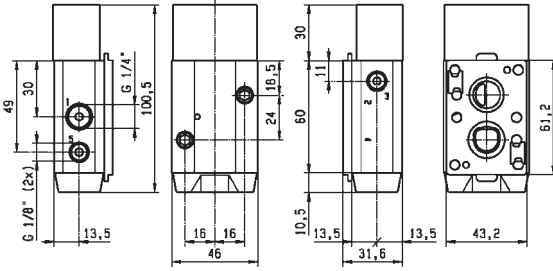
NAMUR

5/2 FUNCTION

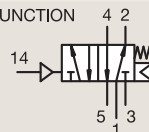

COMMANDE PAR AIR - RAPPEL PAR RESSORT

Raccord	Orifice Ø	Facteur d'Écoulement	Pression Différentielle			Temp. Fluide		Joint	Electrovannes PARKER LUCIFER®			Zone ATEX	Mode de Protection	Puissance		Groupe Electrique	N° Schéma
			Min	Max	Max	Min	Max		Ref. Valve	Ref. Boîtier	Ref. Bobine			AC W	DC W		
BSP	1	Qn l/min	bar	AC bar	DC bar	°C	°C										
1/4"	7	1250	2.5	10	10	-10	50	NBR	541N03	-	-	-	-	-	-	-	8064
1/2"	12	3000	2.5	10	10	-10	50	NBR	541N04	-	-	-	-	-	-	-	8066

ALUMINIUM ANODISÉ

NAMUR

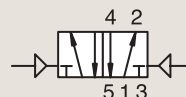

COMMANDE ET RAPPEL PAR AIR

Raccord	Orifice Ø	Facteur d'Écoulement	Pression Différentielle			Temp. Fluide		Joint	Electrovannes PARKER LUCIFER®			Zone ATEX	Mode de Protection	Puissance		Groupe Electrique	N° Schéma
			Min	Max	Max	Min	Max		Ref. Valve	Ref. Boîtier	Ref. Bobine			AC W	DC W		
BSP	1	Qn l/min	bar	AC bar	DC bar	°C	°C										
1/4"	7	1250	2.5	10	10	-10	50	NBR	547N03	-	-	-	-	-	-	-	8059



Dans cette page	Raccord	Orifice (mm)	Qn (l/min)	Pression Diff. Max. (bar)	Temp. Fluide (°C)	Temp. Amb. (°C)
de	1/4"	7	1250	10	-10	-10
à	1/2"	12	3000	10	50	50



Schéma 8064



Schéma 8066

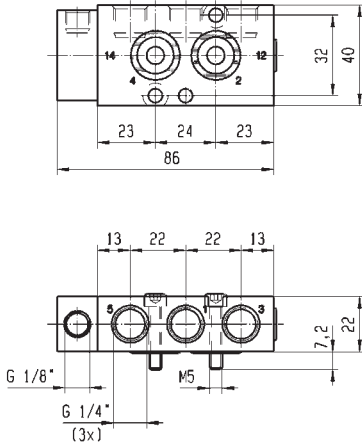

Schéma 8059

5/3

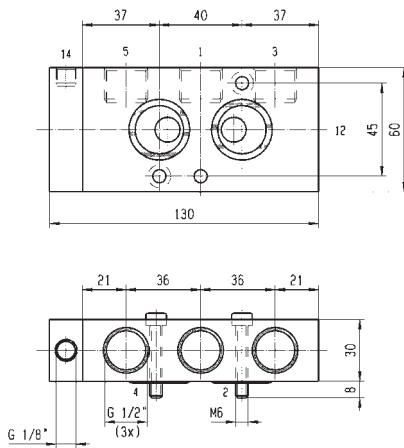
DISTRIBUTEURS 3 & 5 VOIES POUR COMMANDE D'ACTIONNEURS PNEUMATIQUES (NAMUR) PILOTAGE EXTERNE

ALUMINIUM ANODISÉ

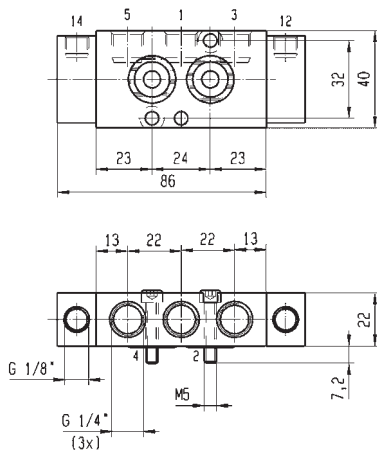
NAMUR

W1 FERMÉE EN POSITION CENTRALE

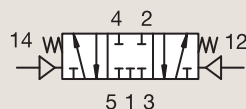

Raccord	Orifice Ø	Facteur d'Écoulement	Pression Différentielle			Temp. Fluide		Joint	Electrovannes PARKER LUCIFER®			Zone ATEX	Mode de Protection	Puissance		Groupe Electrique	N° Schéma
			Min	Max	DC	Min	Max		Ref. Valve	Ref. Boîtier	Ref. Bobine			AC W	DC W		
BSP	1	Qn l/min	bar	AC bar	DC bar	Min °C	Max °C										
1/4"	7	1250	2.5	10	10	-10	50	NBR	542N03	-	-	-	-	-	-	-	8059



Dans cette page	Raccord	Orifice (mm)	Qn (l/min)	Pression Diff. Max. (bar)	Temp. Fluide (°C)	Temp. Amb. (°C)
de	1/4"	7	1250	10	-10	-10
à	1/4"	7	1250	10	50	50



Schéma 8059

DISTRIBUTEURS 3 & 5 VOIES POUR COMMANDE D'ACTIONNEURS PNEUMATIQUES

DISTRIBUTEURS 3 & 5 VOIES INOX 316L POUR COMMANDE D'ACTIONNEURS PNEUMATIQUES (RACCORD TUYAU ET NAMUR)

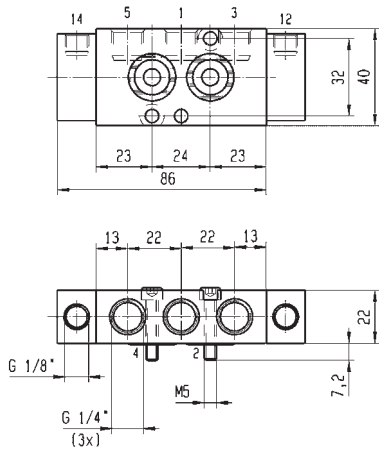

3/2
5/2

Commande	Corps de Valve	Fonction	Raccord	Orifice (mm)	Facteur d'Écoulement Qn(l/min)	Pression Différentielle (bar)	Temp. Max. Fluide (°C)	Page Valves Parker	Page Valves Parker LUCIFER®	
Commande Directe	Inox 316L //Raccord tuyau	Universelle	1/4"	2 à 6	680	12	80	-	376	
			3/8"	6	680	10	75	-	382	
	Inox 316L /Montage sur embase	Fermée hors tension	5 mm	2.5	220	14	80	-	384	
			6 mm	2.5	220	10	75	-	384	
			Universel	1/4"	6	680	10	65	-	384
	Inox 316L /NAMUR	Fermée hors tension	3/8"	6	680	10	75	-	386	
Servo-commande	Inox 316L //Raccord tuyau	Fermée hors tension	3/8"	8	1400	10	80	-	388	
			Inox 316L //Raccord tuyau/Tiroir	Fermée hors tension	3/8"	8	1400	10	80	-
	Inox 316L /NAMUR/Tiroir	Double Bobines	3/8"	8	1400	10	80	-	392	
			Fermée hors tension	3/8"-1/4"	8	1400	10	80	-	394
			Commande par Solénoïde-rappel par ressort	3/8"-1/4"	8	1400	10	80	-	396
	Double Bobines	3/8"-1/4"	8	1400	10	80	-	398		
Réarmement manuel	Inox 316L //Raccord tuyau	Universelle	1/4"	6	680	10	75	-	400	
			3/8"	6	680	10	65	-	404	

3/2

DISTRIBUTEURS 3 & 5 VOIES INOX 316L POUR COMMANDE
D'ACTIONNEURS PNEUMATIQUES (RACCORD TUYAU ET NAMUR)
COMMANDE DIRECTE



Process

INOX 316L RACCORD TUYAU

UNIVERSELLE

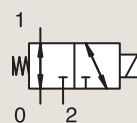

Raccord	Orifice Ø 1 mm	Facteur d'Écoulement Qn l/min	Pression Différentielle		Temp. Fluide		Joint	Electrovannes PARKER LUCIFER®			Zone ATEX	Mode de Protection	Puissance		Groupe Électrique	N° Schéma	
			Min bar	Max AC bar DC bar	Min °C	Max °C		Ref. Valve	Ref. Boîtier	Ref. Bobine			AC W	DC W			
1/4" NPT	2	140	0	12	12	-25	65	FKM	U133V5595 ₁	-	492310	1-21	Ex e mb II T3 to T6	6	6	9.0/10.1	6713
	2	140	0	-	12	-25	75	FKM	U133V5595 ₁	-	492965.01	0-20	Ex ia IIC T6	-	0.3 to 3	9.0/10.1	6713
	2	140	0	12	12	-25	65	FKM	U133V5595 ₁	-	496800	1-21	Ex d mb IIC T4	8	8	9.0/10.1	6713
	2	140	0	12	12	-25	80	FKM	U133V55951D ₁	-	483270.02	1-21	Ex d IIC T4 to T6	8	8	11.0	6714
	2	140	0	12	12	-25	65	FKM	U133V7595	-	492310	1-21	Ex e mb II T3 to T6	6	6	9.0/10.1	8166
	2	140	0	-	12	-25	60	FKM	U133V7595	-	492965.01	0-20	Ex ia IIC T6	-	0.3 to 3	9.0/10.1	8166
	2	140	0	-	12	-25	65	FKM	U133V7595	-	496565	0-20	Ex ia IIB/IIC T4 to T6	-	0.3	9.0/10.1	8166
	2.5	220	0	-	8.5	-25	75	FKM	U133V5695 ₁	-	492210	1-21	Ex e mb II T3 to T6	-	1.8	9.0/10.1	6713
	2.5	220	0	-	8.5	-25	75	FKM	U133V5695 ₁	-	492965.01	0-20	Ex ia IIC T6	-	1.8	9.0/10.1	6713
	2.5	220	0	8.5	8.5	-25	75	FKM	U133V5695 ₁	-	496800	1-21	Ex d mb IIC T4	8	8	9.0/10.1	6713
	2.5	220	0	8.5	8.5	-10	75	FKM	U133V56951D ₁₂	-	483270.02	1-21	Ex d IIC T4 to T6	8	8	11.0	6714
	2.5	220	0	8.5	8.5	-25	75	FKM	U133V7695	-	492310	1-21	Ex e mb II T3 to T6	6	6	9.0/10.1	8166
	2.5	220	0	-	8.5	-25	65	FKM	U133V7695	-	492965.01	0-20	Ex ia IIC T6	-	0.3 to 3	9.0/10.1	8166
	2.5	220	0	-	8.5	-25	65	FKM	U133V7695	-	496565	0-20	Ex ia IIB/IIC T4 to T6	-	0.3	9.0/10.1	8166

Notes:

- 1.Valve livrée avec un certificat individuel de traçabilité matière
- 2.Valve uniquement compatible avec huile hydraulique, air et gaz neutres



Dans cette page	Raccord	Orifice (mm)	Qn (l/min)	Pression Diff. Max. (bar)	Temp. Fluide (°C)	Temp. Amb. (°C)
de	1/4"	2	140	8.5	-25	-25
à	1/4"	2.5	220	12	80	50



Schéma 6713



Schéma 6714

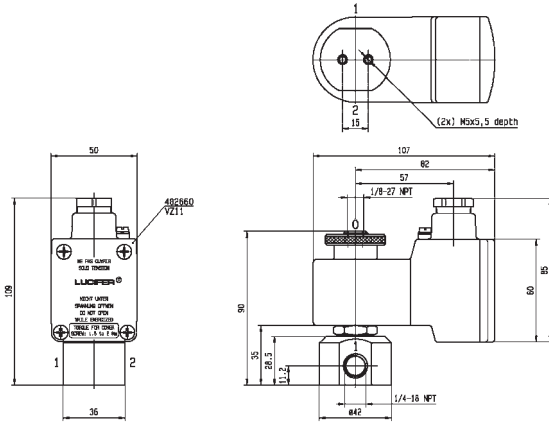

Schéma 8166

3/2

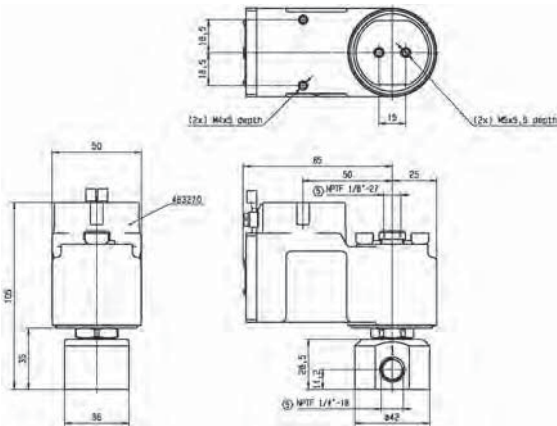
DISTRIBUTEURS 3 & 5 VOIES INOX 316L POUR COMMANDE D'ACTIONNEURS PNEUMATIQUES (RACCORD TUYAU ET NAMUR) COMMANDE DIRECTE

INOX 316L

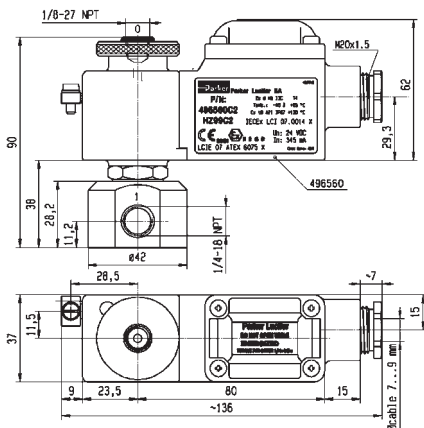
RACCORD TUYAU

UNIVERSELLE

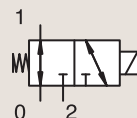

Raccord	Orifice Ø 1 mm	Facteur d'Écoulement Qn l/min	Pression Différentielle			Temp. Fluide		Joint	Electrovannes PARKER LUCIFER®			Zone ATEX	Mode de Protection	Puissance		Groupe Electrique	N° Schéma
			Min bar	Max AC bar	Max DC bar	Min °C	Max °C		Ref. Valve	Ref. Boîtier	Ref. Bobine			AC W	DC W		
1/4" NPTF	6	680	0	10	10	-25	65	NBR	U133X5152 ₁₂	-	492310	1-21	Ex e mb II T3 to T6	6	6	10.1	7770
	6	680	0	10	10	-25	65	NBR	U133X5152 ₁₂	-	496700	1-21	Ex d mb IIC T4 to T6	6	6	10.1	7770
	6	680	0	-	10	-25	65	NBR	U133X5156 ₁₃	-	482870.01	0-20	Ex ia IIC T6	-	0.3 to 3	9.0/10.1/10.2	7770
	6	680	0	10	10	-25	65	NBR	U133X5156 ₁₃	-	492310	1-21	Ex e mb II T3 to T6	6	6	9.0/10.1/10.2	7770
	6	680	0	-	10	-25	65	NBR	U133X5156 ₁₃	-	492965.01	0-20	Ex ia IIC T6	-	0.3 to 3	9.0/10.1/10.2	7770
	6	680	0	10	10	-25	65	NBR	U133X5156 ₁₃	-	496700	1-21	Ex d mb IIC T4 to T6	6	6	9.0/10.1/10.2	7770
	6	680	0	10	10	-25	75	NBR	U133X51561D ₁₃	-	483270.02	1-21	Ex d IIC T4 to T6	8	8	11.0	7011
	6	680	0	10	10	-25	65	NBR	U133X5192 ₂₃	-	492310	1-21	Ex e mb II T3 to T6	6	6	10.1	6904
	6	680	0	10	10	-25	65	NBR	U133X5192 ₂₃	-	496700	1-21	Ex d mb IIC T4 to T6	6	6	10.1	6904
	6	680	0	-	10	-25	65	NBR	U133X5196 ₃	-	492210	1-21	Ex e mb II T3 to T6	-	1.8	9.0/10.1/10.2	6904
	6	680	0	-	10	-25	65	NBR	U133X5196 ₃	-	492965.01	0-20	Ex ia IIC T6	-	0.3 to 3	9.0/10.1/10.2	6904
	6	680	0	10	10	-25	65	NBR	U133X5196 ₃	-	496700	1-21	Ex d mb IIC T4 to T6	6	6	9.0/10.1/10.2	6904

Notes:

1. Avec Commande manuelle
2. Courant continu seulement. Chute de tension maxi admissible égale à 15% du nominal (DIN 19251)
3. Valve livrée avec un certificat individuel de traçabilité matière



Dans cette page	Raccord	Orifice (mm)	Qn (l/min)	Pression Diff. Max. (bar)	Temp. Fluide (°C)	Temp. Amb. (°C)
de	1/4"	6	680	10	-25	-25
à	1/4"	6	680	10	75	65



Schéma 7770



Schéma 7011

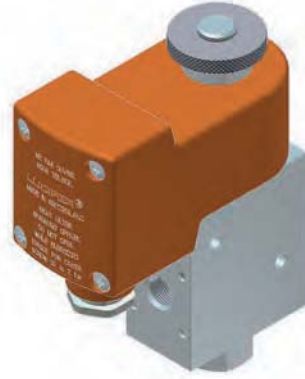
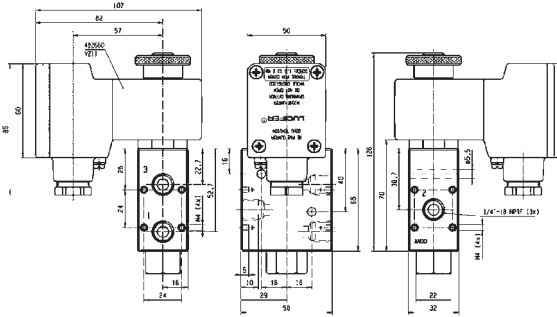

Schéma 6904

3/2

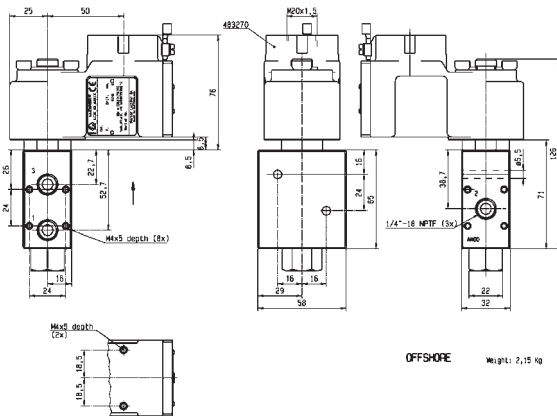
DISTRIBUTEURS 3 & 5 VOIES INOX 316L POUR COMMANDE D'ACTIONNEURS PNEUMATIQUES (RACCORD TUYAU ET NAMUR) COMMANDE DIRECTE

INOX 316L

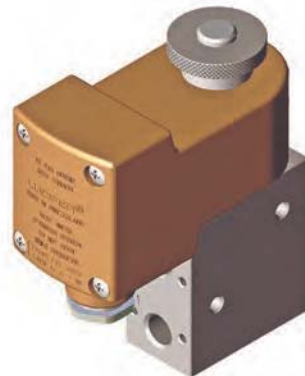
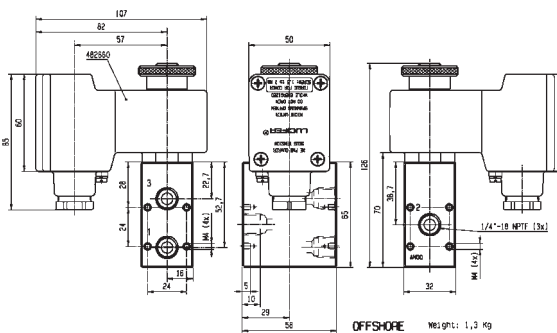
RACCORD TUYAU

UNIVERSELLE

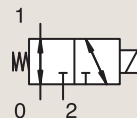

Raccord	Orifice Ø 1 mm	Facteur d'Écoulement Qn l/min	Pression Différentielle		Temp. Fluide		Joint	Electrovannes PARKER LUCIFER®			Zone ATEX	Mode de Protection	Puissance		Groupe Electrique	N° Schéma
			Min bar	Max AC DC bar	Min °C	Max °C		Ref. Valve	Ref. Boîtier	Ref. Bobine			AC W	DC W		
1/4" NPTF	6	680	0	10 10	-25 65	NBR	U133X51961D ₂	-	483270.02	1-21	Ex d IIC T4 to T6	8	8	11.0	7038	
	6	680	0	10 10	-25 65	NBR	U133X7156 ₁	-	496700	1-21	Ex d mb IIC T4 to T6	6	6	9.0/10.1/10.2	8168	
	6	680	0	- 10	-25 65	NBR	U133X7196	-	492210	1-21	Ex e mb II T3 to T6	-	1.8	10.1/10.2	8169	
	6	680	0	- 10	-25 65	NBR	U133X7196	-	492965.01	0-20	Ex ia IIC T6	-	0.3 to 3	10.1/10.2	8169	
	6	680	0	10 10	-25 65	NBR	U133X7196	-	496700	1-21	Ex d mb IIC T4 to T6	6	6	10.1/10.2	8169	

Notes:

1. Avec Commande manuelle
2. Valve livrée avec un certificat individuel de traçabilité matière



Dans cette page	Raccord	Orifice (mm)	Qn (l/min)	Pression Diff. Max. (bar)	Temp. Fluide (°C)	Temp. Amb. (°C)
de	1/4"	6	680	10	-25	-25
à	1/4"	6	680	10	65	65



Schéma 7038



Schéma 8168

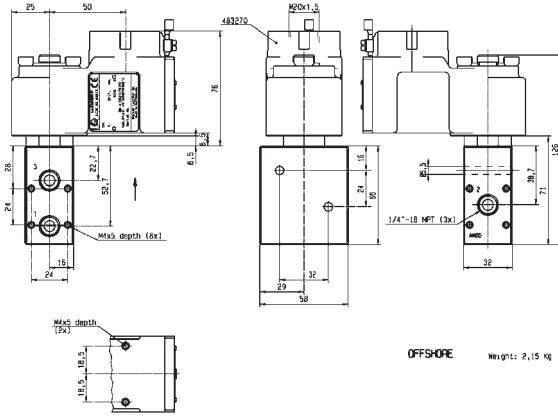

Schéma 8169

3/2

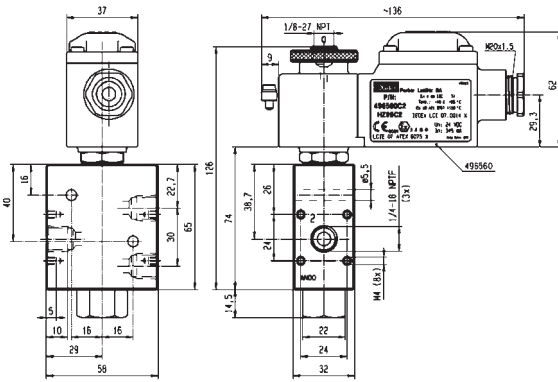
DISTRIBUTEURS 3 & 5 VOIES INOX 316L POUR COMMANDE
D'ACTIONNEURS PNEUMATIQUES (RACCORD TUYAU ET NAMUR)
COMMANDE DIRECTE

INOX 316L

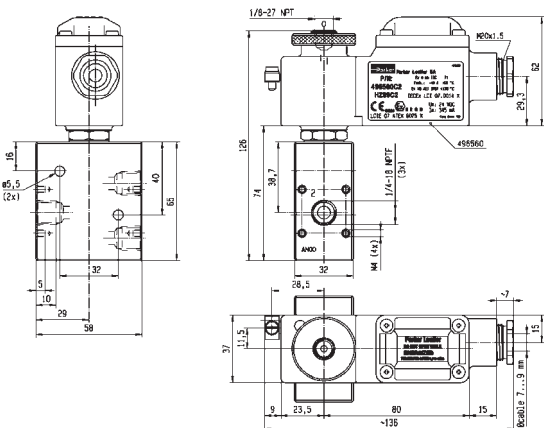
RACCORD TUYAU

UNIVERSELLE

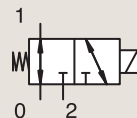

Raccord	Orifice Ø 1 mm	Facteur d'Ecoulement Qn l/min	Pression Différentielle			Temp. Fluide		Joint	Electrovannes PARKER LUCIFER®			Zone ATEX	Mode de Protection	Puissance		Groupe Electrique	N° Schéma
			Min bar	Max AC bar	Max DC bar	Min °C	Max °C		Ref. Valve	Ref. Boîtier	Ref. Bobine			AC W	DC W		
3/8" NPTF	6	680	0	10	10	-25	65	NBR	U133X5296 ₁	-	492310	1-21	Ex e mb II T3 to T6	6	6	9.0/10.1/10.2	7669
	6	680	0	-	10	-25	65	NBR	U133X5296 ₁	-	492965.01	0-20	Ex ia IIC T6	-	0.3 to 3	9.0/10.1/10.2	7669
	6	680	0	10	10	-25	65	NBR	U133X5296 ₁	-	496700	1-21	Ex d mb IIC T4 to T6	6	6	9.0/10.1/10.2	7669
	6	680	0	10	10	-25	75	NBR	U133X52961D ₁	-	483270.02	1-21	Ex d IIC T4 to T6	8	8	11.0	7670

Notes:

1.Valve livrée avec un certificat individuel de traçabilité matière



Dans cette page	Raccord	Orifice (mm)	Qn (l/min)	Pression Diff. Max. (bar)	Temp. Fluide (°C)	Temp. Amb. (°C)
de	3/8"	6	680	10	-25	-25
à	3/8"	6	680	10	75	65



Schéma 7669



Schéma 7670

3/2

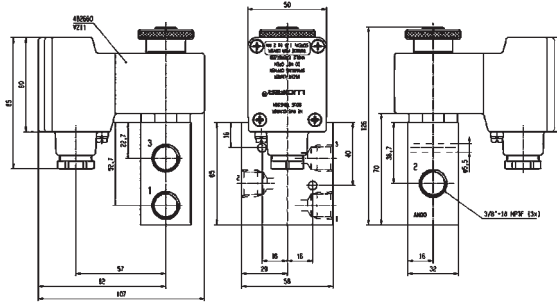
DISTRIBUTEURS 3 & 5 VOIES INOX 316L POUR COMMANDE D'ACTIONNEURS PNEUMATIQUES (RACCORD TUYAU ET NAMUR) COMMANDE DIRECTE

INOX 316L MONTAGE SUR EMBASE FERMÉE HORS TENSION

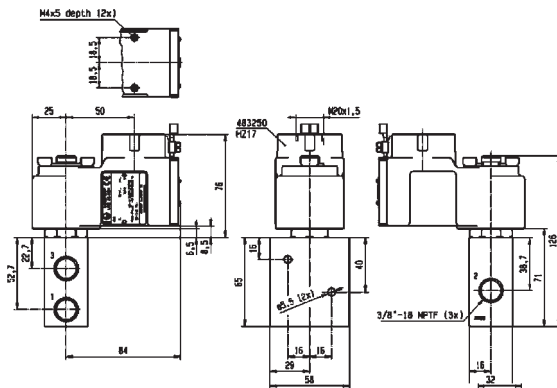
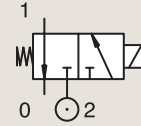

Raccord	Orifice Ø 1 mm	Facteur d'Écoulement Qn l/min	Pression Différentielle			Temp. Fluide		Joint	Electrovannes PARKER LUCIFER®			Zone ATEX	Mode de Protection	Puissance		Groupe Electrique	N° Schéma
			Min bar	Max AC bar	Max DC bar	Min °C	Max °C		Ref. Valve	Ref. Boîtier	Ref. Bobine			AC W	DC W		
SB	2.5	220	0	-	12	-25	65	FKM	U131F5695 ₁	-	492210	1-21	Ex e mb II T3 to T6	-	1.8	9.0/10.1	3782
	2.5	220	0	-	12	-25	65	FKM	U131F5695 ₁	-	492965.01	0-20	Ex ia IIC T6	-	0.3 to 3	9.0/10.1	3782
	2.5	220	0	12	12	-25	75	FKM	U131F5695 ₁	-	496800	1-21	Ex d mb IIC T4	8	8	9.0/10.1	3782
	2.5	220	0	14	14	-10	80	FKM	U131F56951D ₁₂	-	483270.02	1-21	Ex d IIC T4 to T6	8	8	11.0	3783
SB	2.5	220	0	10	10	-25	75	FKM	U131F5295	-	496560	1-21	Ex d mb IIC T4	8	8	9.0/10.1	8174

Notes:

- 1.Valve livrée avec un certificat individuel de traçabilité matière
- 2.Valve uniquement compatible avec huile hydraulique, air et gaz neutres

INOX 316L MONTAGE SUR EMBASE UNIVERSELLE

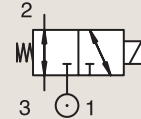

Raccord	Orifice Ø 1 mm	Facteur d'Écoulement Qn l/min	Pression Différentielle			Temp. Fluide		Joint	Electrovannes PARKER LUCIFER®			Zone ATEX	Mode de Protection	Puissance		Groupe Electrique	N° Schéma
			Min bar	Max AC bar	Max DC bar	Min °C	Max °C		Ref. Valve	Ref. Boîtier	Ref. Bobine			AC W	DC W		
1/4" NPTF	6	680	0	10	10	-25	65	FKM	U133X5195 ₁	-	492310	1-21	Ex e mb II T3 to T6	6	6	9.0/10.1/10.2	3572
	6	680	0	10	10	-25	65	FKM	U133X5195 ₁	-	496700	1-21	Ex d mb IIC T4 to T6	6	6	9.0/10.1/10.2	3572

Notes:

- 1.Valve livrée avec un certificat individuel de traçabilité matière



Schéma 3572



Dans cette page	Raccord	Orifice (mm)	Qn (l/min)	Pression Diff. Max. (bar)	Temp. Fluide (°C)	Temp. Amb. (°C)
de	SB	2.5	220	10	-25	-25
à	SB	6	680	14	80	50

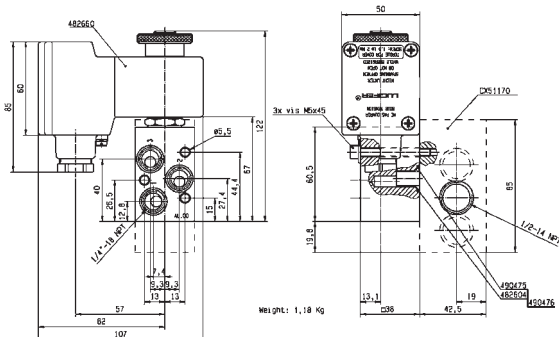

Schéma 3782



Schéma 3783

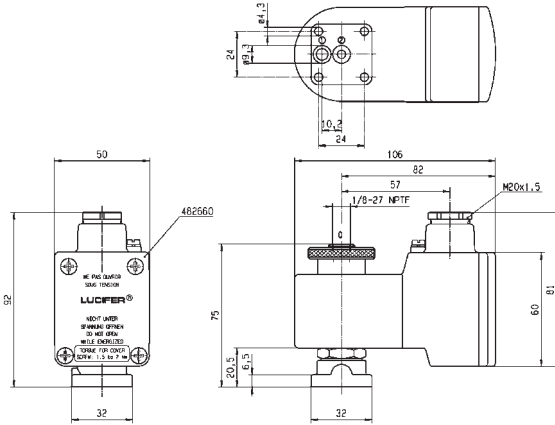

Schéma 8174

3/2

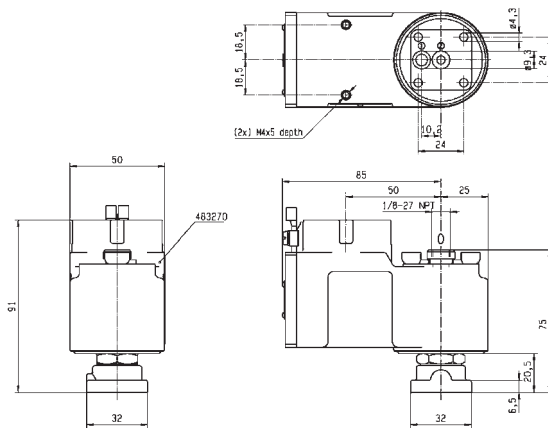
DISTRIBUTEURS 3 & 5 VOIES INOX 316L POUR COMMANDE D'ACTIONNEURS PNEUMATIQUES (RACCORD TUYAU ET NAMUR) COMMANDE DIRECTE

INOX 316L

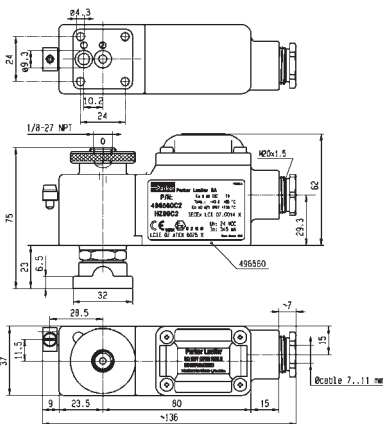
MONTAGE SUR EMBASE

UNIVERSELLE

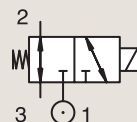

Raccord	Orifice Ø 1 mm	Facteur d'Écoulement Qn l/min	Pression Différentielle		Temp. Fluide		Joint	Electrovannes PARKER LUCIFER®			Zone ATEX	Mode de Protection	Puissance		Groupe Electrique	N° Schéma	
			Min	Max	Min	Max		Ref. Valve	Ref. Boîtier	Ref. Bobine			AC W	DC W			
			bar	AC bar	DC bar	°C		°C									
1/4" NPTF	6	680	0	10	10	-25	65	FKM	U133X51951D ₁	-	483270	1-21	Ex d IIC T4 to T6	8	8	11.0	3688
	6	680	0	10	10	-25	65	FKM	U133X51951D ₁	-	483270.02	1-21	Ex d IIC T4 to T6	8	8	11.0	3688
	6	680	0	-	10	-25	65	FKM	U133X7195	-	492210	1-21	Ex e mb II T3 to T6	-	1.8	9.0/10.1/10.2	8172
	6	680	0	-	10	-25	65	FKM	U133X7195	-	492965.01	0-20	Ex ia IIC T6	-	0.3 to 3	9.0/10.1/10.2	8172
	6	680	0	10	10	-25	65	FKM	U133X7195	-	496700	1-21	Ex d mb IIC T4 to T6	6	6	9.0/10.1/10.2	8172

Notes:

1.Valve livrée avec un certificat individuel de traçabilité matière

INOX 316L

NAMUR

FERMÉE HORS TENSION

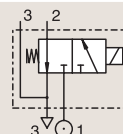

Raccord	Orifice Ø 1 mm	Facteur d'Écoulement Qn l/min	Pression Différentielle		Temp. Fluide		Joint	Electrovannes PARKER LUCIFER®			Zone ATEX	Mode de Protection	Puissance		Groupe Electrique	N° Schéma	
			Min	Max	Min	Max		Ref. Valve	Ref. Boîtier	Ref. Bobine			AC W	DC W			
			bar	AC bar	DC bar	°C		°C									
3/8" NPT	6	680	0	10	10	-25	65	NBR	U131X1201 ₁	-	492310	1-21	Ex e mb II T3 to T6	6	6	9.0/10.1/10.2	7668
	6	680	0	-	10	-25	75	NBR	U131X1201 ₁	-	492965.01	0-20	Ex ia IIC T6	-	0.3 to 3	9.0/10.1/10.2	7668
	6	680	0	10	10	-25	65	NBR	U131X1201 ₁	-	496700	1-21	Ex d mb IIC T4 to T6	6	6	9.0/10.1/10.2	7668

Notes:

1.Valve livrée avec un certificat individuel de traçabilité matière



Dans cette page	Raccord	Orifice (mm)	Qn (l/min)	Pression Diff. Max. (bar)	Temp. Fluide (°C)	Temp. Amb. (°C)
de	1/4"	6	680	10	-25	-25
à	3/8"	6	680	10	75	50



Schéma 3688



Schéma 8172

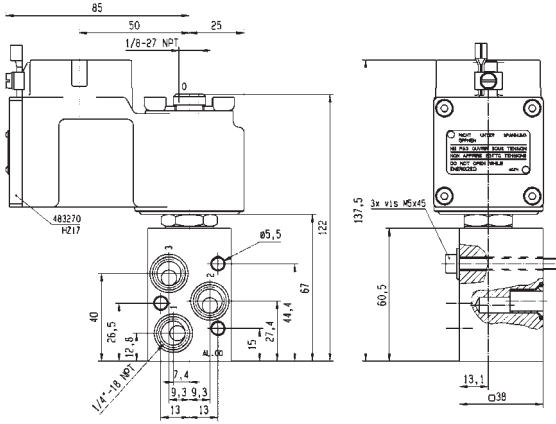

Schéma 7668

5/2

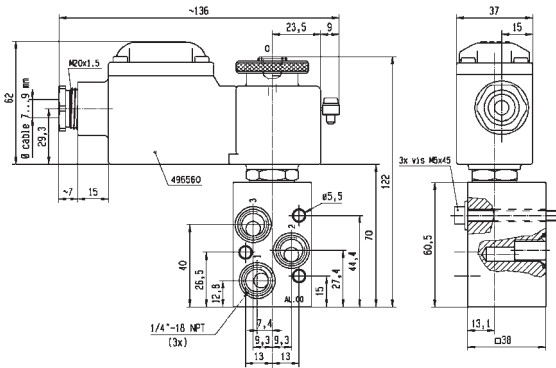
DISTRIBUTEURS 3 & 5 VOIES INOX 316L POUR COMMANDE
D'ACTIONNEURS PNEUMATIQUES (RACCORD TUYAU ET NAMUR)
SERVO-COMMANDE

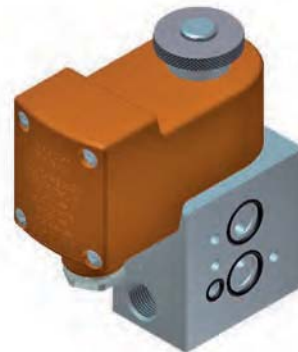
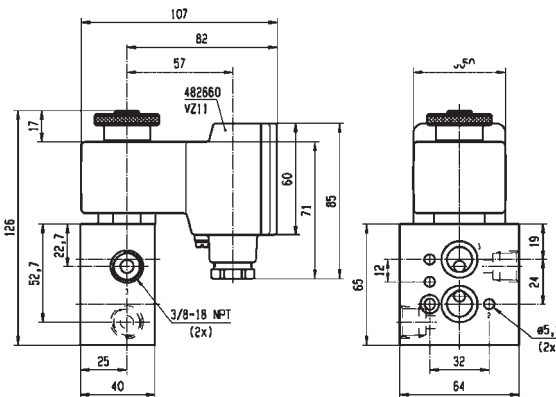

Process

INOX 316L

RACCORD TUYAU

FERMÉE HORS TENSION

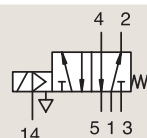

Raccord	Orifice Ø 1 mm	Facteur d'Écoulement Qn l/min	Pression Différentielle			Temp. Fluide		Joint	Electrovannes PARKER LUCIFER®			Zone ATEX	Mode de Protection	Puissance		Groupe Electrique	N° Schéma
			Min bar	Max AC bar	Max DC bar	Min °C	Max °C		Ref. Valve	Ref. Boîtier	Ref. Bobine			AC W	DC W		
3/8" NPT	8	1400	2	10	10	-25	80	NBR	U441P3250 ₁₂	4270	481000	-	-	8	8	2.1	7565
	8	1400	2	10	10	-25	80	NBR	U441P3250 ₁₂	2995	481865	-	-	8	9	2.1	7565

Notes:

1. Joint du clapet de pilotage en FKM
2. Valve avec pilotage externe, pression minimum 4 bar

INOX 316L

RACCORD TUYAU

FERMÉE HORS TENSION

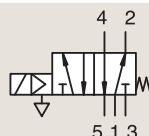

Raccord	Orifice Ø 1 mm	Facteur d'Écoulement Qn l/min	Pression Différentielle			Temp. Fluide		Joint	Electrovannes PARKER LUCIFER®			Zone ATEX	Mode de Protection	Puissance		Groupe Electrique	N° Schéma
			Min bar	Max AC bar	Max DC bar	Min °C	Max °C		Ref. Valve	Ref. Boîtier	Ref. Bobine			AC W	DC W		
3/8" NPT	8	1400	2	10	10	-25	80	NBR	U341P0250 ₁₂₃	8993	481045	-	-	2	2.5	1.1	7578
	8	1400	2	10	10	-25	80	NBR	U341P0250 ₁₂₃	-	482606	1-21 Ex mb IIC T4/T5	-	2	2.5	1.1	7578
	8	1400	2	10	10	-25	80	NBR	U341P3250 ₃	4270	481000	-	-	8	8	2.1	7558
	8	1400	2	10	10	-25	80	NBR	U341P3250 ₃	2995	481865	-	-	8	9	2.1	7558
	8	1400	2	10	10	-25	80	NBR	U341P3250 ₃	2995	492453	-	-	8	9	2.1	7558

Notes:

1. Avec Commande manuelle
2. Avec échappement collecté
3. Joint du clapet de pilotage en FKM



Dans cette page	Raccord	Orifice (mm)	Qn (l/min)	Pression Diff. Max. (bar)	Temp. Fluide (°C)	Temp. Amb. (°C)
de	3/8"	8	1400	10	-25	-25
à	3/8"	8	1400	10	80	50



Schéma 7565



Schéma 7578

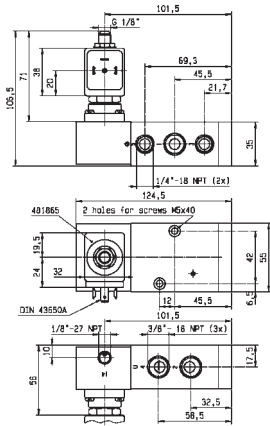

Schéma 7558

5/2

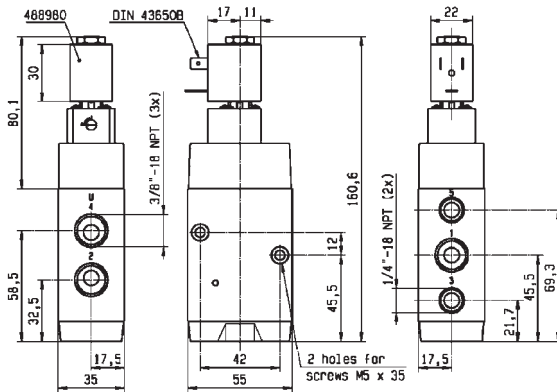
DISTRIBUTEURS 3 & 5 VOIES INOX 316L POUR COMMANDE
D'ACTIONNEURS PNEUMATIQUES (RACCORD TUYAU ET NAMUR)
SERVO-COMMANDE

INOX 316L

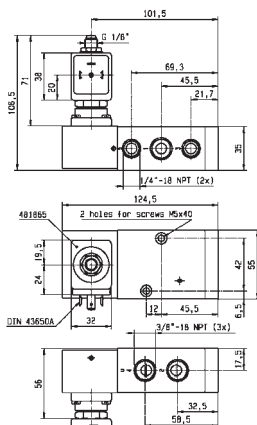
RACCORD TUYAU

FERMÉE HORS TENSION

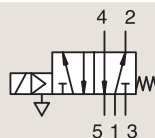

Raccord	Orifice Ø 1	Facteur d'Écoulement Qn l/min	Pression Différentielle			Temp. Fluide		Joint	Electrovannes PARKER LUCIFER®			Zone ATEX	Mode de Protection	Puissance		Groupe Électrique	N° Schéma
			Min bar	Max AC bar	DC bar	Min °C	Max °C		Ref. Valve	Ref. Boîtier	Ref. Bobine			AC W	DC W		
3/8" NPT	8	1400	2	-	10	-25	55	NBR	U341P3292	2995	483580.01	0-20	Ex ia IIC T6	-	0.5 to 3	7.0	7560
	8	1400	2	10	10	-25	75	NBR	U341P3295	-	492310	1-21	Ex e mb II T3 to T6	6	6	9.0/10.1	7561
	8	1400	2	-	10	-25	75	NBR	U341P3295	-	492965.01	0-20	Ex ia IIC T6	-	0.3 to 3	9.0/10.1	7561

Notes:

1. Joint du clapet de pilotage en FKM



Dans cette page	Raccord	Orifice (mm)	Qn (l/min)	Pression Diff. Max. (bar)	Temp. Fluide (°C)	Temp. Amb. (°C)
de	3/8"	8	1400	10	-25	-25
à	3/8"	8	1400	10	75	50



Schéma 7560



Schéma 7561

5/2

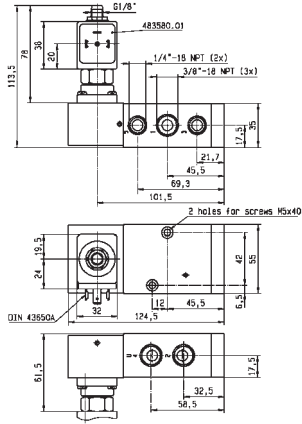
DISTRIBUTEURS 3 & 5 VOIES INOX 316L POUR COMMANDE
D'ACTIONNEURS PNEUMATIQUES (RACCORD TUYAU ET NAMUR)
SERVO-COMMANDE

INOX 316L

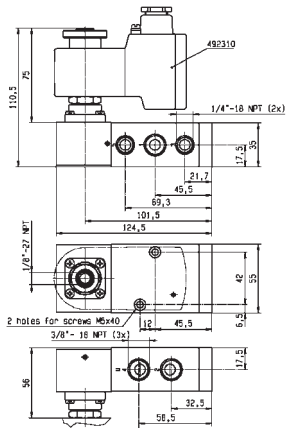
RACCORD TUYAU

COMMANDE PAR 2 SOLENOIDES

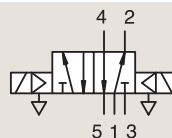

Raccord	Orifice Ø 1	Facteur d'Écoulement Qn l/min	Pression Différentielle			Temp. Fluide		Joint	Electrovannes PARKER LUCIFER®			Zone ATEX	Mode de Protection	Puissance		Groupe Electrique	N° Schéma
			Min	Max		Min	Max		Ref. Valve	Ref. Boîtier	Ref. Bobine			AC W	DC W		
	mm		bar	AC bar	DC bar	°C	°C										
3/8" NPT	8	1400	2	10	10	-25	80	NBR	U347P3250 ₁	4270	481000	-	-	8	8	2.1	7563
	8	1400	2	10	10	-25	80	NBR	U347P3250 ₁	-	483371	1-21	Ex e mb IIC T4	8	8	2.1	7563
	8	1400	2	10	10	-25	75	NBR	U347P3295 ₁	-	492310	1-21	Ex e mb II T3 to T6	6	6	10.1	7564
	8	1400	2	10	10	-25	75	NBR	U347P3295 ₁	-	496800	1-21	Ex d mb IIC T4	8	8	10.1	7564

Notes:

1. Joint du clapet de pilotage en FKM



Dans cette page	Raccord	Orifice (mm)	Qn (l/min)	Pression Diff. Max. (bar)	Temp. Fluide (°C)	Temp. Amb. (°C)
de	3/8"	8	1400	10	-25	-25
à	3/8"	8	1400	10	80	50



Schéma 7563



Schéma 7564

3/2-5/2

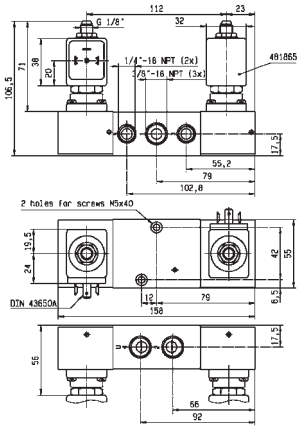
DISTRIBUTEURS 3 & 5 VOIES INOX 316L POUR COMMANDE
D'ACTIONNEURS PNEUMATIQUES (RACCORD TUYAU ET NAMUR)
SERVO-COMMANDE

INOX 316L
NAMUR

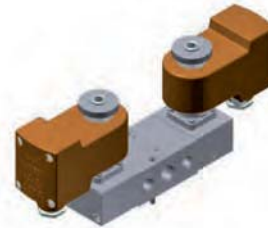
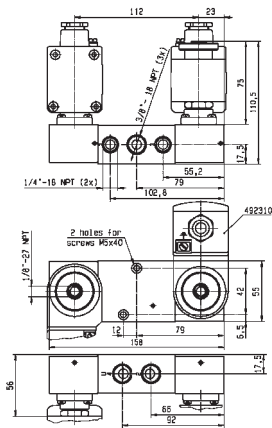
FERMÉE HORS TENSION

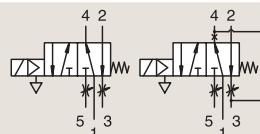

Raccord	Orifice Ø 1 mm	Facteur d'Écoulement Qn l/min	Pression Différentielle		Temp. Fluide		Joint	Electrovannes PARKER LUCIFER®			Zone ATEX	Mode de Protection	Puissance		Groupe Electrique	N° Schéma	
			Min bar	Max DC bar	Min °C	Max °C		Ref. Valve	Ref. Boîtier	Ref. Bobine			AC W	DC W			
3/8"- 1/4" NPT	8	1400	2	10	10	-25	80	NBR	U341N3250 ₁	2995	481865	-	-	8	9	2.1	7554
	8	1400	2	10	10	-25	80	NBR	U341N3250 ₁	-	492190	1-21	Ex e mb IIC T3/T4	11	9	2.1	7554
	8	1400	2	-	10	-25	55	NBR	U341N3292 ₁	2995	483580.01	0-20	Ex ia IIC T6	-	0.5 to 3	7.0	7556
	8	1400	2	10	10	-25	75	NBR	U341N3295 ₁	-	492310	1-21	Ex e mb II T3 to T6	6	6	10.1	7696
	8	1400	2	10	10	-25	75	NBR	U341N3295 ₁	-	496800	1-21	Ex d mb IIC T4	8	8	10.1	7696

Notes:

1. Joint du clapet de pilotage en FKM



Dans cette page	Raccord	Orifice (mm)	Qn (l/min)	Pression Diff. Max. (bar)	Temp. Fluide (°C)	Temp. Amb. (°C)
de	3/8"-1/4"	8	1400	10	-25	-25
à	3/8"-1/4"	8	1400	10	80	50



Schéma 7554



Schéma 7556

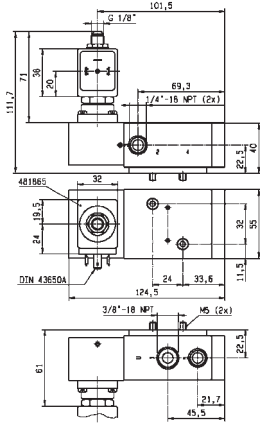

Schéma 7696

3/2-5/2

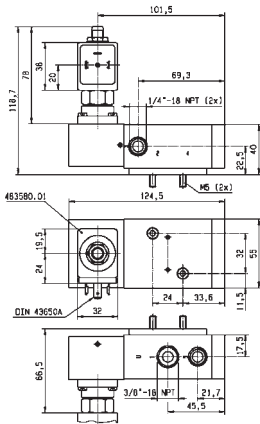
DISTRIBUTEURS 3 & 5 VOIES INOX 316L POUR COMMANDE
D'ACTIONNEURS PNEUMATIQUES (RACCORD TUYAU ET NAMUR)
SERVO-COMMANDE

**INOX 316L
NAMUR**

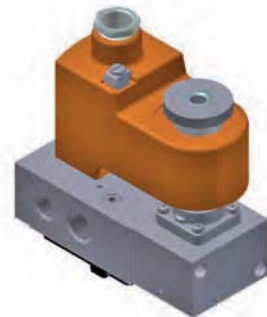
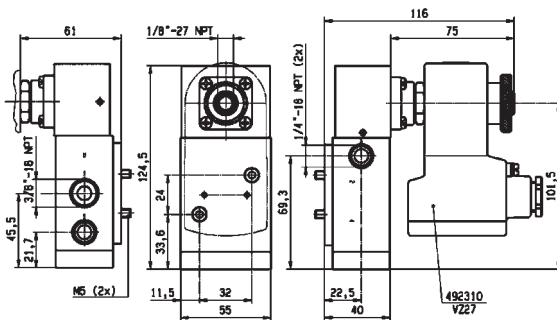
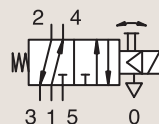

COMMANDE PAR SOLENOÏDE-RAPPEL PAR RESSORT

Raccord	Orifice Ø 1 mm	Facteur d'Écoulement Qn l/min	Pression Différentielle			Temp. Fluide		Joint	Electrovannes PARKER LUCIFER®			Zone ATEX	Mode de Protection	Puissance		Groupe Électrique	N° Schéma
			Min bar	Max AC bar DC bar		Min °C	Max °C		Ref. Valve	Ref. Boîtier	Ref. Bobine			AC W	DC W		
3/8"- 1/4"NPT	8	1400	2	10	10	-25	80	NBR	U341N0250 ₁₂₃	-	482606	1-21	Ex mb IIC T4/T5	2	2.5	1.1	7577
	8	1400	2	10	10	-25	80	NBR	U341N0250 ₁₂₃	8993	488980	-	-	2	2.5	1.1	7577

Notes:

1. Avec Commande manuelle
2. Avec échappement collecté
3. Joint du clapet de pilotage en FKM



Dans cette page	Raccord	Orifice (mm)	Qn (l/min)	Pression Diff. Max. (bar)	Temp. Fluide (°C)	Temp. Amb. (°C)
de	3/8"-1/4"	8	1400	10	-25	-25
à	3/8"-1/4"	8	1400	10	80	50



Schéma 7577

5/2

DISTRIBUTEURS 3 & 5 VOIES INOX 316L POUR COMMANDE
D'ACTIONNEURS PNEUMATIQUES (RACCORD TUYAU ET NAMUR)
SERVO-COMMANDE

INOX 316L
NAMUR

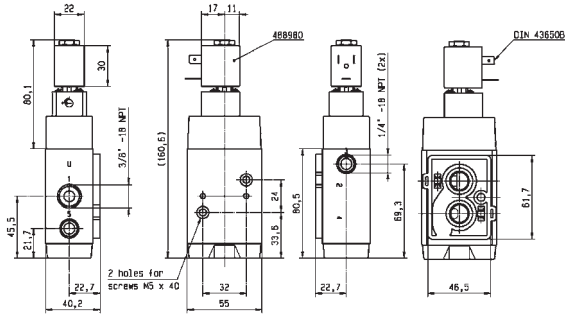
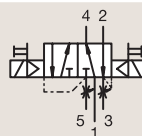

COMMANDE PAR 2 SOLENOIDES

Raccord	Orifice Ø 1 mm	Facteur d'Écoulement Qn l/min	Pression Différentielle			Temp. Fluide		Joint	Electrovannes PARKER LUCIFER®			Zone ATEX	Mode de Protection	Puissance		Groupe Electrique	N° Schéma
			Min bar	Max AC bar	Max DC bar	Min °C	Max °C		Ref. Valve	Ref. Boîtier	Ref. Bobine			AC W	DC W		
3/8"- 1/4"NPT	8	1400	2	10	10	-25	80	NBR	U347N3250 ₁	4270	481000	-	-	8	8	2.1	7557
	8	1400	2	10	10	-25	80	NBR	U347N3250 ₁	2995	481865	-	-	8	9	2.1	7557

Notes:

1. Joint du clapet de pilotage en FKM



Dans cette page	Raccord	Orifice (mm)	Qn (l/min)	Pression Diff. Max. (bar)	Temp. Fluide (°C)	Temp. Amb. (°C)
de	3/8"-1/4"	8	1400	10	-25	-25
à	3/8"-1/4"	8	1400	10	80	50



Schéma 7557

3/2

DISTRIBUTEURS 3 & 5 VOIES INOX 316L POUR COMMANDE
D'ACTIONNEURS PNEUMATIQUES (RACCORD TUYAU ET NAMUR)
RÉARMEMENT MANUEL

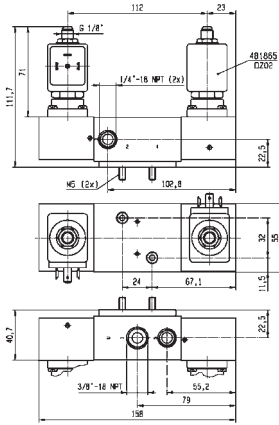

Process

**INOX 316L
RACCORD TUYAU**

UNIVERSELLE

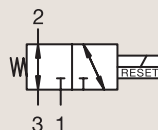

Raccord	Orifice Ø 1 mm	Facteur d'Écoulement Qn l/min	Pression Différentielle		Temp. Fluide		Joint	Electrovannes PARKER LUCIFER®			Zone ATEX	Mode de Protection	Puissance		Groupe Electrique	N° Schéma	
			Min bar	Max AC bar DC bar	Min °C	Max °C		Ref. Valve	Ref. Boîtier	Ref. Bobine			AC W	DC W			
1/4" NPTF	6	680	0	10	10	-25	65	NBR	U033X5152 ₁₂	-	492310	1-21	Ex e mb II T3 to T6	6	6	10.1/10.2	7029
	6	680	0	-	10	-25	65	NBR	U033X5156 ₂	-	482870.01	0-20	Ex ia IIC T6	-	0.3 to 3	10.1/10.2/12.0	7771
	6	680	0	10	10	-25	65	NBR	U033X5156 ₂	-	492310	1-21	Ex e mb II T3 to T6	6	6	10.1/10.2/12.0	7771
	6	680	0	-	10	-25	65	NBR	U033X5156 ₂	-	492335	0-20	NEMA 4-4X	-	0.3 to 3	10.1/10.2/12.0	7771
	6	680	0	10	10	-25	65	NBR	U033X5156 ₂	-	496700	1-21	Ex d mb IIC T4 to T6	6	6	10.1/10.2/12.0	7771
	6	680	0	10	10	-25	75	NBR	U033X51561D ₂	-	483270.02	1-21	Ex d IIC T4 to T6	8	8	11.0	7030

Notes:

1. Courant continu seulement. Chute de tension maxi admissible égale à 15% du nominal (DIN 19251)
2. Valve livrée avec un certificat individuel de traçabilité matière



Dans cette page	Raccord	Orifice (mm)	Qn (l/min)	Pression Diff. Max. (bar)	Temp. Fluide (°C)	Temp. Amb. (°C)
de	1/4"	6	680	10	-25	-25
à	1/4"	6	680	10	75	65



Schéma 7029



Schéma 7771

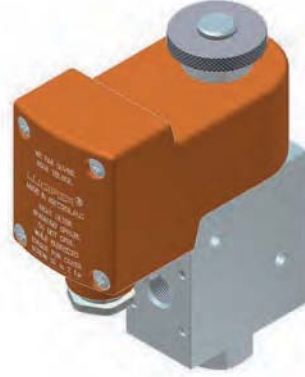
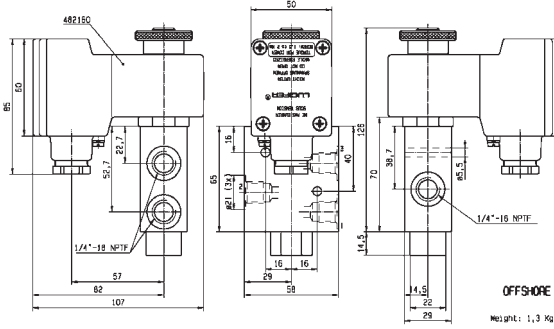

Schéma 7030

3/2

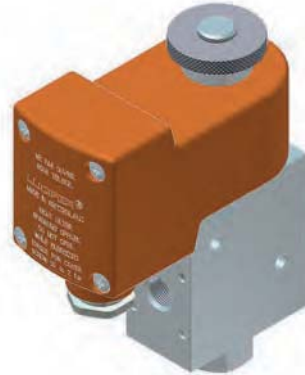
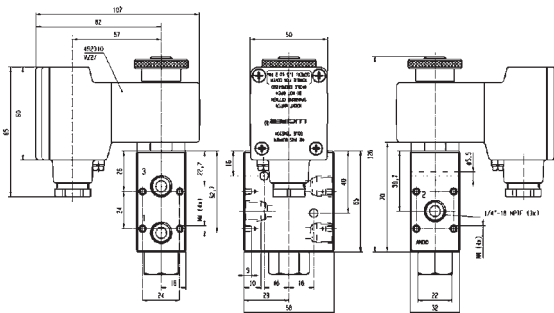
DISTRIBUTEURS 3 & 5 VOIES INOX 316L POUR COMMANDE
D'ACTIONNEURS PNEUMATIQUES (RACCORD TUYAU ET NAMUR)
RÉARMEMENT MANUEL

INOX 316L

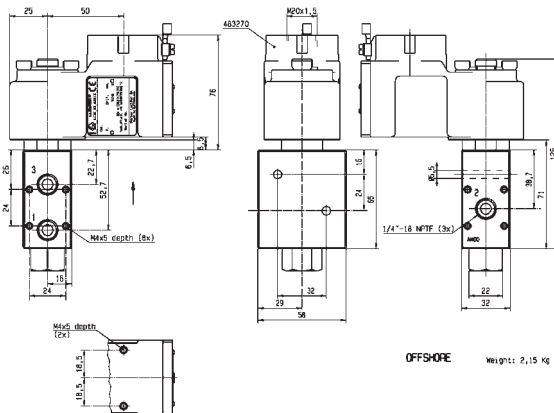
RACCORD TUYAU

UNIVERSELLE

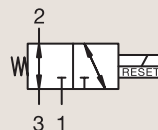

Raccord	Orifice Ø 1 mm	Facteur d'Écoulement Qn l/min	Pression Différentielle		Temp. Fluide		Joint	Electrovannes PARKER LUCIFER®			Zone ATEX	Mode de Protection	Puissance		Groupe Electrique	N° Schéma	
			Min bar	Max AC bar	Max DC bar	Min °C		Max °C	Ref. Valve	Ref. Boîtier			Ref. Bobine	AC W			DC W
1/4" NPTF	6	560	0	10	10	-25	65	NBR	U033X5195 ₂	-	492310	1-21	Ex e mb II T3 to T6	6	6	10.1/10.2/12.0	3594
	6	560	0	10	10	-25	65	NBR	U033X5195 ₂	-	496700	1-21	Ex d mb IIC T4 to T6	6	6	10.1/10.2/12.0	3594
	6	680	0	10	10	-25	65	NBR	U033X7156 ₁	-	492310	1-21	Ex e mb II T3 to T6	6	6	10.1/10.2	8168
	6	680	0	10	10	-25	65	NBR	U033X7156	-	496560	1-21	Ex d mb IIC T4	8	8	10.1/10.2	8168
	6	680	0	10	10	-25	65	NBR	U033X7156	-	496700	1-21	Ex d mb IIC T4 to T6	6	6	10.1/10.2	8168
	6	680	0	10	10	-25	65	NBR	U033X7156	-	496895	-	-	8	8	10.1/10.2	8168

Notes:

1. Courant continu seulement. Chute de tension maxi admissible égale à 15% du nominal (DIN 19251)

2. Valve livrée avec un certificat individuel de traçabilité matière



Dans cette page	Raccord	Orifice (mm)	Qn (l/min)	Pression Diff. Max. (bar)	Temp. Fluide (°C)	Temp. Amb. (°C)
de	1/4"	6	680	10	-25	-25
à	1/4"	6	680	10	65	65



Schéma 3594



Schéma 8168

3/2

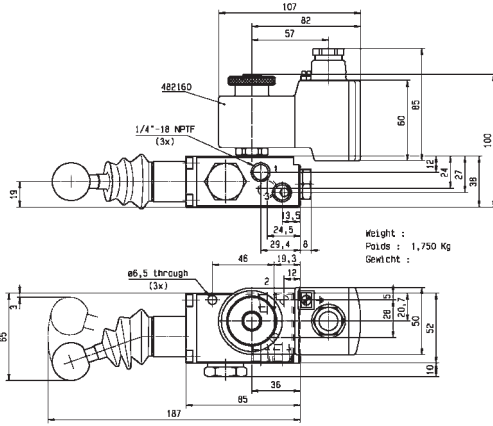
DISTRIBUTEURS 3 & 5 VOIES INOX 316L POUR COMMANDE
D'ACTIONNEURS PNEUMATIQUES (RACCORD TUYAU ET NAMUR)
RÉARMEMENT MANUEL

INOX 316L

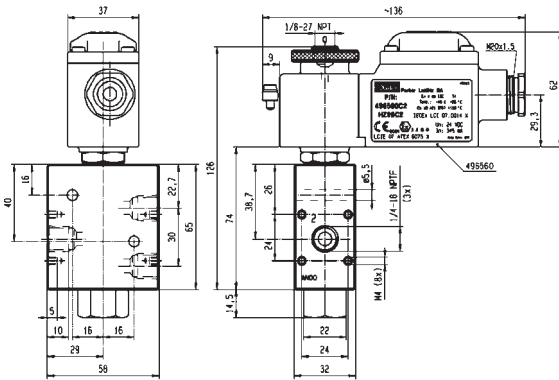
RACCORD TUYAU

UNIVERSELLE

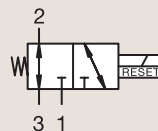

Raccord	Orifice Ø 1 mm	Facteur d'Écoulement Qn l/min	Pression Différentielle		Temp. Fluide		Joint	Electrovannes PARKER LUCIFER®			Zone ATEX	Mode de Protection	Puissance		Groupe Electrique	N° Schéma	
			Min bar	Max AC bar	DC bar	Min °C		Max °C	Ref. Valve	Ref. Boîtier			Ref. Bobine	AC W			DC W
3/8" NPTF	6	680	0	-	10	-25	65	NBR	U033X5256 ₂	-	482870.01	0-20	Ex ia IIC T6	-	0.3 to 3	10.1/10.2/12.0	7671
	6	680	0	10	10	-25	65	NBR	U033X5256 ₂	-	492310	1-21	Ex e mb II T3 to T6	6	6	10.1/10.2/12.0	7671
	6	680	0	10	10	-25	65	NBR	U033X5256 ₂	-	496700	1-21	Ex d mb IIC T4 to T6	6	6	10.1/10.2/12.0	7671
	6	680	0	10	10	-25	65	NBR	U033X52561D ₂	-	483270	1-21	Ex d IIC T4 to T6	8	8	11.0	7672
	6	680	0	10	10	-25	65	NBR	U033X52561D ₂	-	483270.02	1-21	Ex d IIC T4 to T6	8	8	11.0	7672

Notes:

- 1.Courant continu seulement. Chute de tension maxi admissible égale à 15% du nominal (DIN 19251)
- 2.Valve livrée avec un certificat individuel de traçabilité matière



Dans cette page	Raccord	Orifice (mm)	Qn (l/min)	Pression Diff. Max. (bar)	Temp. Fluide (°C)	Temp. Amb. (°C)
de	3/8"	6	680	10	-25	-25
à	3/8"	6	680	10	65	65



Schéma 7671



Schéma 7672

POUR LA COMMANDE D'ACTIONNEURS PNEUMATIQUES DANS LES ZONES ATEX

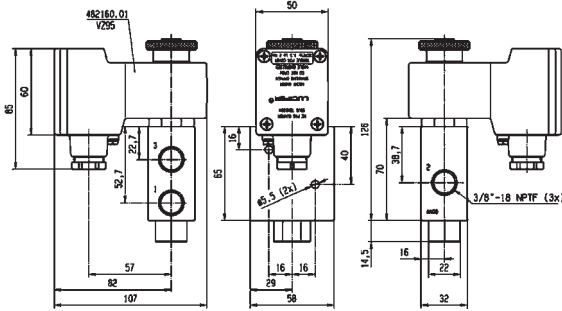

aerospace
climate control
electromechanical
filtration
fluid & gas handling
hydraulics
pneumatics
process control
sealing & shielding

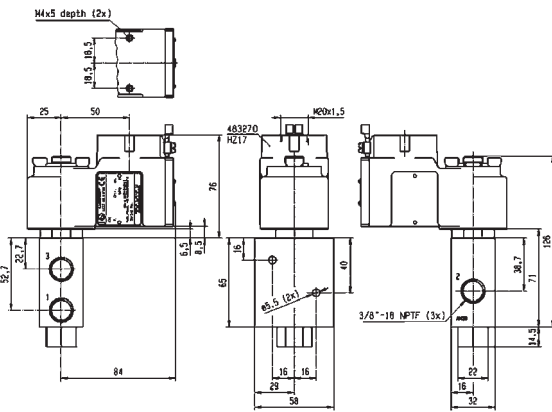



POUR LA COMMANDE D'ACTIONNEURS PNEUMATIQUES

MANIFOLD COMMANDÉ PAR BUS ATEX POUR LA COMMANDE D'ACTIONNEURS PNEUMATIQUES

Les collecteurs par bus EExPress™ de Parker permettent de commander des actionneurs pneumatiques dans le secteur du process, pour des environnements considérés comme dangereux (ex. : zone 1, 21 et/ou zone 2, 22).

EExPress™ est un système empilable comprenant une gateway, des modules de capteur d'entrée et des modules d'électrovanne. Standard NAMUR ON/OFF sur lequel le capteur (NPN) peut être directement connecté sur le module du capteur d'entrée.

Le manifold Ex utilise le protocole Profibus DP.



AUGMENTATION DE LA PRODUCTIVITÉ

- Plus les installations de l'usine sont simplifiées, plus il est facile de réduire les coûts en matière d'étude de projet, d'emballage des composants et de main d'œuvre ; la production peut ainsi démarrer plus rapidement.
- Un contrôle efficace des processus permet d'améliorer la qualité et la quantité de la production.
- Le manifold commandé par bus EExPress™ bus remplace une grande partie des composants brevetés et réduit ainsi les coûts d'installation.
- Le manifold commandé par bus EExPress™ simplifie les opérations de mise en service, pour un démarrage plus rapide de la ligne de production.
- Le manifold commandé par bus EExPress™ réduit les coûts généraux liés au cycle de vie du produit grâce à une meilleure gestion des coûts de maintenance.

UN PRODUIT CONVIVAL

- EExPress™ est basé sur le protocole Profibus DP.
- Il a été conçu pour une utilisation de type « Plug and Play ».
- Le voyant renseigne immédiatement l'utilisateur sur l'état du processus de production en cours.
- Les utilisateurs autorisés peuvent adresser les vannes 5/2 directement depuis le manifold.



SIMPLIFICATION DES INSTALLATIONS

- EExPress™ permet de réduire considérablement les besoins en composants électroniques (ex. : coupleurs, répéteurs, barrières de sécurité, PLC, etc.).
- Solution intégrée avec vannes haut débit et entrées de signal de capteur.
- Permet de réduire considérablement les besoins en composants mécaniques (ex. : armoires pressurisées; tuyaux pneumatiques, câbles électriques, connecteurs, etc.).
- Un bus permet de contrôler jusqu'à 32 électrovannes sur un collecteur (ou plusieurs modules de capteur et électrovannes).

DES PROCESSUS ET UNE SÉCURITÉ DU PERSONNEL PLUS EFFICACES

- Grâce au câblage séparé, les systèmes de communication par bus restent actifs même en cas de coupure de courant.
 - État de l'électrovanne + état du capteur d'entrée + état du système de sécurité de la pression, etc.
 - Les fonctionnalités de diagnostic assurent un contrôle des processus extrêmement fiable.
 - Permet un contrôle des processus plus efficace grâce à sa position centrale, près des actionneurs.
 - La protection Ex px [ia] [ib] mb IIC T5 Ex tD A21 IP65 T100°C et le système breveté de connexion des bobines éliminent tout risque d'erreur de manipulation.
- Exemple : déconnexion de connecteurs de bus ou de capteur en présence de gaz.

EFFICACITÉ PROUVÉE GRÂCE À UN CONTRÔLE CONTINU ET NOVATEUR



IECEx LCI 07.0027 X



LCIE 01 ATEX 6013 X

Ex px [ia] [ib] mb IIC T5
Ex tD A21 IP65 T100°C



GAMME DE RÉGULATEURS DE PRESSION PROPORTIONNELS



aerospace
 climate control
 electromechanical
 filtration
 fluid & gas handling
 hydraulics
 pneumatics
 process control
 sealing & shielding



Basic	1/4" 1/2"
Comfort	1/4" 1/2"
Comfort	1/2" HP 1" 2"
Comfort ATEX	1/2" 1" 2"

GAMME DE RÉGULATEURS DE PRESSION PROPORTIONNELS

Régulateur de pression programmable EPP4 Lucifer®

L'EPP4 est un régulateur de pression électropneumatique avec système électronique intégré. Une électrovanne à modulation de largeur d'impulsion commande la pression de sortie proportionnellement à un signal d'entrée analogique. Une précision très élevée est garantie par un signal en boucle fermée de haute précision fourni par un capteur de pression intégré.



Marché

Robotique
Industrie papetière
Machines-outils
Systèmes mobiles
Bâtiments
Textile
Instrumentation
Semi-conducteurs



Description des applications

Soudage
Commande de vitesse et de frein
Sablage
Découpe
Humidification
Régulation de tension
Peinture
Presses
Polissage
Commande de suspension adaptative



Avantages de la gamme Lucifer® EPP4 de régulateurs de pression proportionnels

- Tous les paramètres sont entièrement réglables par le biais du logiciel PC Calys.
- Logiciel facile à utiliser
- Longue durée de vie
- Compact et léger
- Stock optimisé
- Faible consommation d'énergie
- Positionnement flexible de l'écran distant
- Expertise reconnue de Parker, pionnier en matière de technologie de régulation de pression

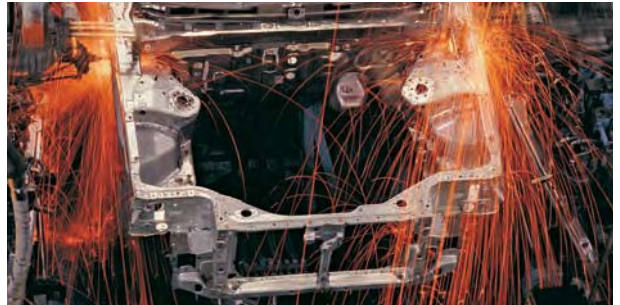
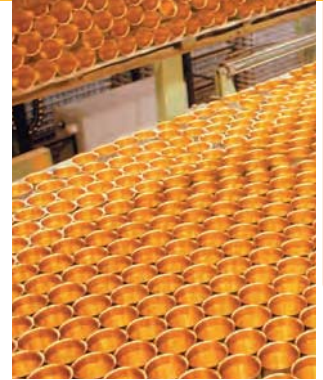

calys - Logiciel pour EPP Comfort

Calys est un logiciel unique développé en interne pour configurer tous les paramètres de la gamme EPP4 Comfort. Calys est une option de l'EPP4. Pour utiliser CALYS, vous devez commander un câble de référence 496449, qui permet la communication entre l'EPP4 et un PC.

Calys offre de nombreuses possibilités :

- Il permet aux distributeurs de réduire leur stock en ne conservant qu'un EPP4 générique, qui peut être ajusté en fonction des besoins de chaque client. Il est, par exemple, possible de passer de 0-10 V à 4-20 mA, ou d'une plage de pressions de 0-7 bar à 0-5 bar.
- Les ingénieurs chargés de concevoir un système pneumatique peuvent surveiller avec précision toutes les valeurs importantes (électriques ou pneumatiques) directement sur leur ordinateur portable.
- Les techniciens du service après-vente peuvent recevoir par e-mail tous les paramètres mesurés par l'EPP4 installé sur une machine, quel que soit son emplacement, ce qui permet d'effectuer une maintenance à distance.
- Les paramètres de régulation PID peuvent être ajustés avec Calys afin de correspondre à la réponse requise du régulateur (par exemple, lent ou réactif).

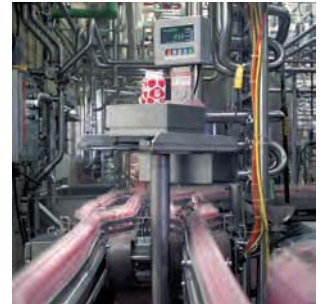

Pour télécharger gratuitement le logiciel Calys, accédez à www.parker.com/FCDE/Support

GAMME DE RÉGULATEURS DE PRESSION PROPORTIONNELS

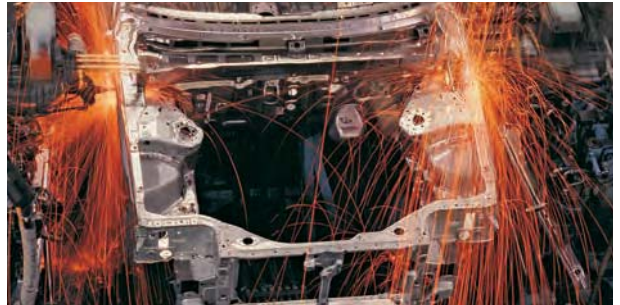

SOMMAIRE

Introduction EPPPage 416

Gamme EPP4 BasicPage 418

**Gamme EPP4
Comfort**Page 422

**Gamme EPP4
Comfort HP**Page 426

**Gamme EPP4
Comfort ATEX**Page 432

AccessoiresPage 438



INTRODUCTION

Description Fonctionnement

La série EPP4 est une famille de régulateurs de pression électropneumatiques à commande électrique à distance avec commande électronique intégrée en boucle fermée.

Ces dispositifs permettent la régulation de la pression de sortie proportionnellement à un signal de commande électrique.

Le régulateur EPP4 comprend un régulateur de pression pneumatique traditionnel à servocommande, dans lequel la chambre pilote est alimentée par l'une ou l'autre de deux électrovannes à 2 voies à largeur d'impulsion modulée.

Le capteur de pression mesure la pression de sortie du régulateur et envoie un signal de réaction au contrôleur.

Toute différence entre le signal de commande et le signal de réaction est convertie en un signal numérique mettant sous tension la bobine de l'une ou l'autre des deux vannes à 2 voies afin de corriger la position du régulateur.

Le signal de commande peut être une tension (0-10 V) ou un courant (4-20 mA).

L'entrée de la "**vanne de remplissage**" est reliée directement à l'entrée principale P du régulateur ; une fois sous tension cette vanne remplit la chambre à servocommande afin d'augmenter la pression à la sortie A du régulateur.

Lorsque l'autre "**vanne d'échappement**" est mise sous tension (diminution de la pression à la sortie A du régulateur), la pression de la chambre à servocommande s'échappe par le biais d'un orifice de refoulement situé entre le couvercle et le corps, et est directement évacuée dans l'atmosphère sans silencieux.

L'échappement de la pression régulée principale s'effectue par le biais de l'échappement rapide R. L'utilisation d'un silencieux conventionnel est recommandée.

Les deux électrovannes assurent le **remplissage** ou le **vidage** de la chambre à servocommande afin d'augmenter ou de diminuer la pression à la sortie du régulateur.

Lorsque les vannes sont en position de repos, tous les ports sont bloqués.

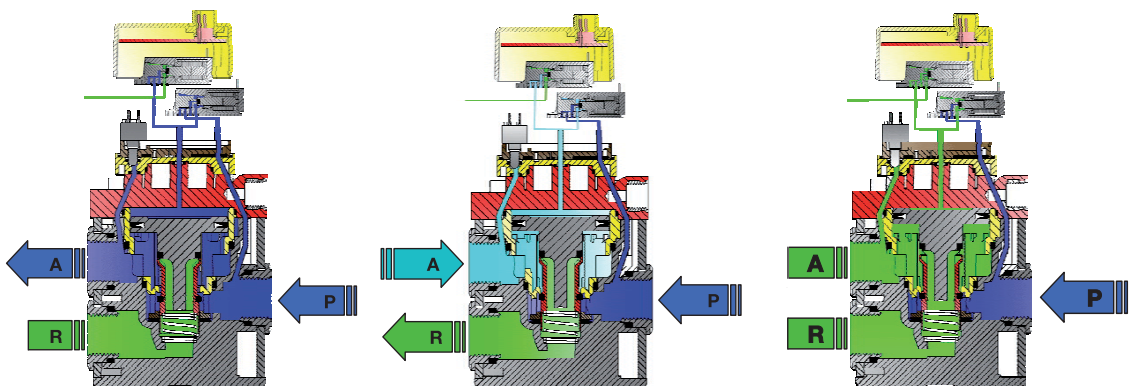

Position de remplissage

Position de veille

Position de vidage

Schéma

Le contrôleur reçoit à la fois le signal de commande (pression de service) et le signal de réaction issu du capteur (pression de sortie).

Toute différence entre les deux entrées d'amplification résulte en une sortie correspondante qui actionne l'électrovanne à 2 voies à largeur d'impulsion modulée appropriée, de telle sorte que le piston pilote se déplace en vue de corriger la pression.

Le même signal de réaction issu du capteur est utilisé pour la réaction de sortie en tension et en courant.

Le signal numérique (alarme) est activé lorsque les conditions (pression hors limites ou tolérance de temps) sont satisfaites.

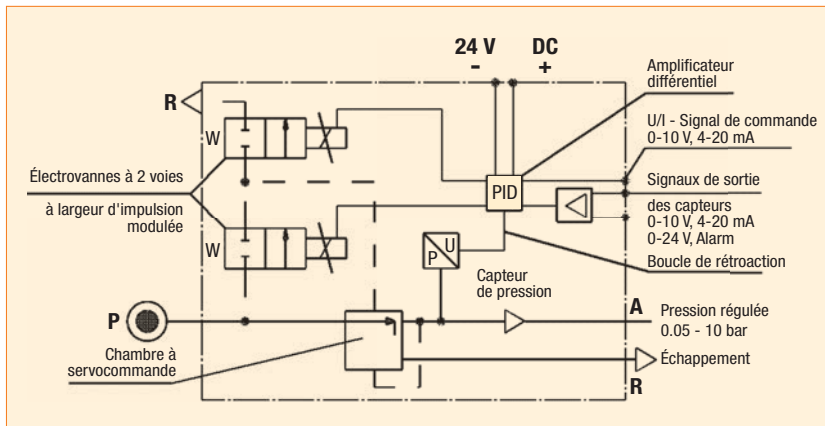

Versions EPP4 possibles : Basic et Comfort

Les gammes EPP4 Basic et Comfort partagent les mêmes pièces mécaniques fiables. La régulation proportionnelle est également identique pour les deux familles de produits, donnant par exemple les mêmes caractéristiques en matière d'hysteresis ou de précision.

Les régulateurs de la gamme Comfort possèdent un deuxième connecteur M12, qui peut être utilisé pour connecter un écran distant affichant la pression régulée actuelle ou un PC pour un réglage aisé des paramètres de régulation. Il s'agit là des caractéristiques clés qui permettent une utilisation confortable des régulateurs.

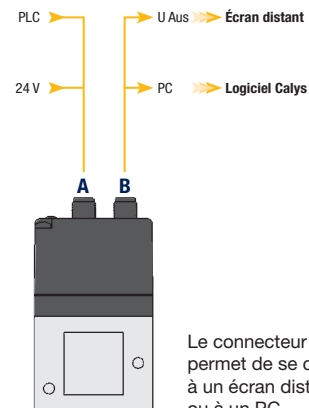

LUCIFER® EPP4 BASIC 1/4" & 1/2"

DONNÉES TECHNIQUES

Basic	1/4" 1/2"
Comfort	1/4" 1/2"
Comfort	1/2" HP 1" 2"
Comfort ATEX	1/2" 1" 2"

	Basic 1/4"	Basic 1/2"
Fluides :	Air et gaz neutres lubrifiés ou non lubrifiés - Filtration recommandée : 50 µm	
Plage de températures :	Température ambiante : de 0 °C à +50 °C Fluide : de 0 °C à +50 °C	
Plage de pression d'entrée : La pression d'entrée doit toujours être supérieure d'au moins 1 bar à la pression régulée.	De 1 à 12 bar	De 1 à 12 bar
Plage de pression de sortie :	De 0,05 à 10 bar	
Hysteresis :	± 50 mbar (valeur définie en usine)	
Consommation d'air à signal de commande constant :	0	
Tension d'alimentation :	24 V CC ± 15 % (ondulation max. 1 V)	
Consommation électrique :	Max. 2,8 W avec 24 V CC et des variations constantes du signal de commande < 1,5 W sans variation du signal de commande	
Signal de commande :	Analogique 0 - 10 V Analogique 4 - 20 mA	
Débit max. : Temps de réaction indicatif : avec un volume de 330 cm³ à la sortie du régulateur	70 m³/h	150 m³/h
Remplissage de 2 à 4 bar : Remplissage de 2 à 8 bar : Vidage de 4 à 2 bar : Vidage de 8 à 2 bar :	50 msec 100 msec 70 msc 130 msc	60 msec 120 msec 90 msec 190 msec
Position de sécurité :	En cas de défaillance du signal de commande ou si celui-ci est inférieur à 50 mV, la pression régulée chute automatiquement à 0 bar (pression atmosphérique). En cas de défaillance de la tension d'alimentation, la pression régulée est maintenue constante.	
Raccord électrique :	M12 - 4 broches ; 4 x 0,34 mm²	
Durée de vie :	> 50 millions de variations de pas de signal de commande	
Position de montage :	Indifférente (position recommandée : verticale ; partie électronique vers le haut)	
Résistance aux vibrations :	30 g dans toutes les directions	
Degré de protection :	IP 65	
Assemblage :	Exempt de silicone	
Compatibilité électromagnétique : En conformité avec :	EN 61000-6-1: 2001 EN 61000-6-2: 2001 EN 61000-6-3: 2001 EN 61000-6-4: 2001	
Instructions d'installation et de réglage :	Voir notre document "Notice 408038, 408014" ainsi que l'annexe fournie avec le produit.	

Remarque : Parker se réserve le droit de modifier les spécifications sans avis préalable.

LUCIFER® EPP4 BASIC 1/4" & 1/2"

COURBES DE DÉBIT

Courbe de débit Basic 1/4"

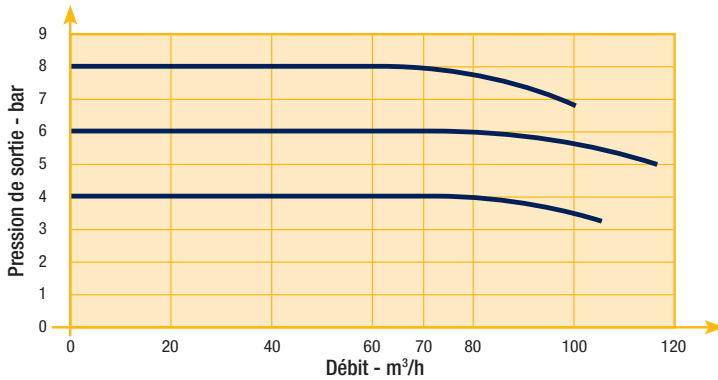

Courbe de débit Basic 1/2"

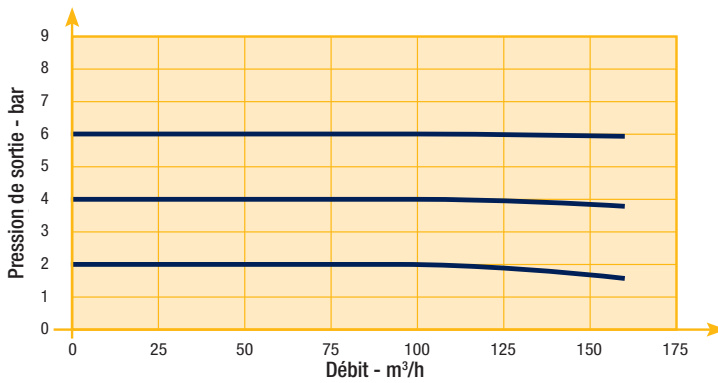

LUCIFER® EPP4 BASIC 1/4" & 1/2"

RÉFÉRENCES

Codes	Raccord	Plage de pression (bar)		Signal de commande (voir options)	Numéro de schéma
P4BG2001A001	G 1/4"	0	4 bar	4 - 20 mA	1
P4BG2001A002	G 1/4"	0	10 bar	0 - 10 V	1
P4BG2001A003	G 1/4"	0	10 bar	4 - 20 mA	1
P4BG2001A004	G 1/4"	0	6 bar	0 - 10 V	1
P4BG2001A005	G 1/4"	0	6 bar	4 - 20 mA	1
P4BG2001A006	G 1/4"	0	5 bar	0 - 10 V	1
P4BG2001A007	G 1/4"	0	5 bar	4 - 20 mA	1
P4BG2001A008	G 1/4"	0	7 bar	0 - 10 V	1
P4BG2001A009	G 1/4"	0	7 bar	4 - 20 mA	1
P4BG2003A002 *	G 1/4"	0	10 bar	0 - 10 V	1
P4BG2003A003 *	G 1/4"	0	10 bar	4 - 20 mA	1
P4BG4001A002	G 1/2"	0	10 bar	0 - 10 V	2
P4BG4001A003	G 1/2"	0	10 bar	4 - 20 mA	2
P4BG4001A004	G 1/2"	0	6 bar	0 - 10 V	2
P4BG4001A005	G 1/2"	0	6 bar	4 - 20 mA	2
P4BG4001A006	G 1/2"	0	5 bar	0 - 10 V	2
P4BG4001A007	G 1/2"	0	5 bar	4 - 20 mA	2
P4BG4001A008	G 1/2"	0	7 bar	0 - 10 V	2
P4BG4001A009	G 1/2"	0	7 bar	4 - 20 mA	2
P4BG4004A010 ***	G 1/2"	0	4 bar	0 - 10 V	2
P4BG4051A002 **	G 1/2"	0	10 bar	4 - 20 mA	2
P4BN2001A002	NPT 1/4"	0	10 bar	4 - 20 mA	2
P4BN2001A003	NPT 1/4"	0	10 bar	0 - 10 V	2
P4BN4001A002	NPT 1/2"	0	10 bar	4 - 20 mA	2
P4BN4001A003	NPT 1/2"	0	10 bar	0 - 10 V	2

* Sortie pilote intégrée

** O2

*** Pression d'alimentation externe



LUCIFER® EPP4 BASIC 1/4" & 1/2"

SCHÉMAS DES DIMENSIONS
EPP4 BASIC 1/4"

Schéma 1

SCHÉMAS DES DIMENSIONS
EPP4 BASIC 1/2"

Schéma 2

LUCIFER® EPP4 COMFORT 1/4" & 1/2"

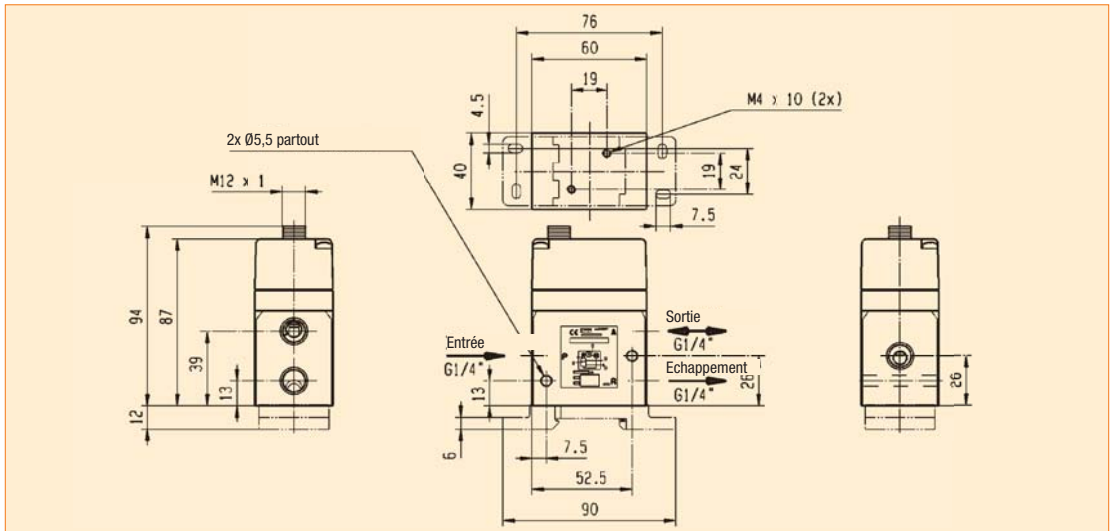
DONNÉES TECHNIQUES

Basic	1/4" 1/2"
Comfort	1/4" 1/2"
Comfort	1/2" HP 1" 2"
Comfort ATEX	1/2" 1" 2"

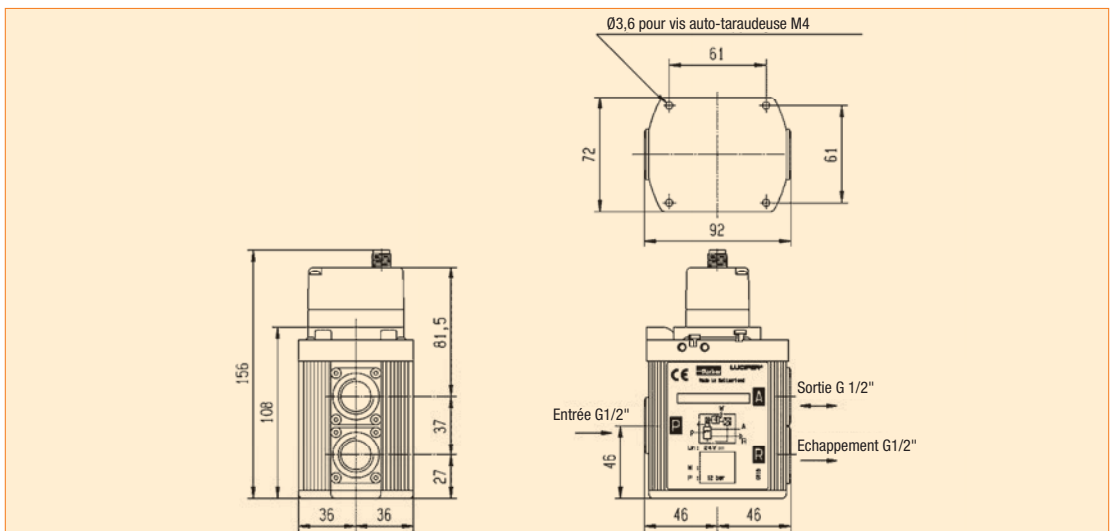
	Comfort 1/4"	Comfort 1/2"
Fluides :	Air et gaz neutres lubrifiés ou non lubrifiés - Filtration recommandée : 50 µm	
Plage de températures :	Température ambiante : de 0 °C à +50 °C Fluide : de 0 °C à +50 °C	
Plage de pression d'entrée : La pression d'entrée doit toujours être supérieure d'au moins 1 bar à la pression régulée.	De 1 à 12 bar	De 1 à 12 bar
Plage de pression de sortie :	De 0,05 à 10 bar	
Hysteresis :	± 50 mbar (valeur définie en usine)	
Consommation d'air à signal de commande constant :	0	
Tension d'alimentation :	24 V CC ± 15 % (ondulation max. 1 V)	
Consommation électrique :	Max. 2,8 W avec 24 V CC et des variations constantes du signal de commande < 1,5 W sans variation du signal de commande	
Signal de commande :	Analogique 0 - 10 V Analogique 4 - 20 mA	
Signal du capteur de sortie :	Analogique 0 - 10 V Standard pour 0 - 10 bar ; réglable Analogique 4 - 20 mA Standard pour 0 - 10 bar ; réglable	Numérique 0/24 V pour fonctions d'alarmes : Erreur de pression réglable (+/-) Délai réglable sur MARCHÉ Délai réglable sur ARRÊT Logique réglable (+/-)
Débit max. :	70 m³/h	150 m³/h
Temps de réaction indicatif :	Avec un volume de 330 cm³ à la sortie du régulateur	
Remplissage de 2 à 4 bar :	50 msec	60 msec
Remplissage de 2 à 8 bar :	100 msec	120 msec
Vidage de 4 à 2 bar :	70 msec	90 msec
Vidage de 8 à 2 bar :	130 msec	190 msec
Position de sécurité :	En cas de défaillance du signal de commande ou si celui-ci est inférieur à 50 mV, la pression régulée chute automatiquement à 0 bar (pression atmosphérique). En cas de défaillance de la tension d'alimentation, la pression régulée est maintenue constante.	
Raccord électrique :	M12 - 8 broches ; alimentation / signal de commande avec connecteur mâle M12 - 5 broches ; communication avec connecteur mâle	
Durée de vie :	> 50 millions de variations de pas de signal de commande	
Position de montage :	Indifférente (position recommandée : verticale ; partie électronique vers le haut)	
Résistance aux vibrations :	30 g dans toutes les directions	
Degré de protection :	IP 65	
Assemblage :	Exempt de silicone	
Compatibilité électromagnétique : En conformité avec :	EN 61000-6-1: 2001 EN 61000-6-2: 2001 EN 61000-6-3: 2001 + A11 édition 2004 (01/07/07) EN 61000-6-4: 2001	
Instructions d'installation et de réglage :	Voir notre document "Notice 408128, 408134" ainsi que l'annexe fournie avec le produit.	

Remarque : Parker se réserve le droit de modifier les spécifications sans avis préalable.

LUCIFER® EPP4 COMFORT 1/4" & 1/2"

COURBES DE DÉBIT

Courbe de débit 1/4"

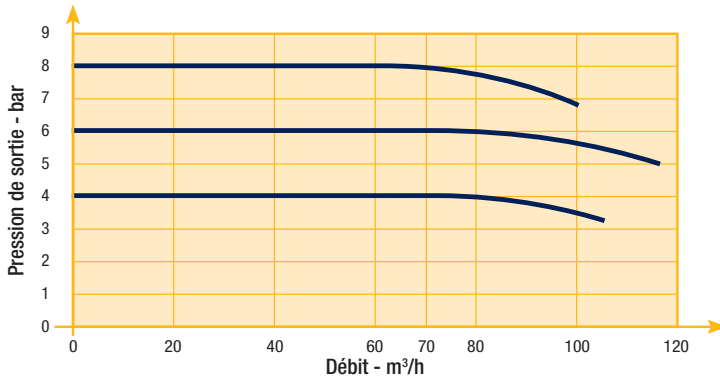

Courbe de débit 1/2"

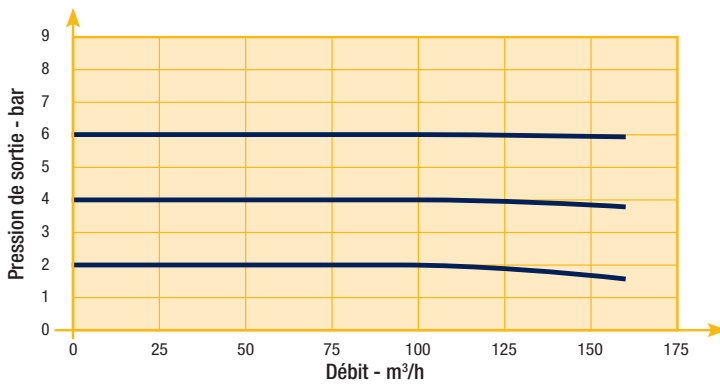

LUCIFER® EPP4 COMFORT 1/4" & 1/2"

RÉFÉRENCES

Codes	Raccord	Plage de pression (bar)		Signal de commande (voir options)	Affichage	Numéro de schéma
P4CG2001C001	G 1/4	0	10	0-10 V	-	3
P4CG2001C002	G 1/4	0	10	4-20 mA	-	3
P4CG2001C005	G 1/4	0	7	0-10 V	-	3
P4CG2001C006	G 1/4	0	7	4-20 mA	-	3
P4CG2002C001	G 1/4	0	10	0-10 V	inclus	3
P4CG2002C002	G 1/4	0	10	4-20 mA	inclus	3
P4CG2003C001 *	G 1/4	0	10	0-10 V	-	3
P4CG2003C002 *	G 1/4	0	10	4-20 mA	-	3
P4CG2002C007	G 1/4	0	7	0-10 V	inclus	3
P4CG2002C008	G 1/4	0	7	4-20 mA	inclus	3
P4CN2001C001	1/4 NPT	0	10	0-10 V	-	3
P4CN2001C002	1/4 NPT	0	10	4-20 mA	-	3
P4CN2002C001	1/4 NPT	0	10	0-10 V	inclus	3
P4CN2002C002	1/4 NPT	0	10	4-20 mA	inclus	3
P4CG4001C001	G 1/2	0	10	0-10 V	-	4
P4CG4001C002	G 1/2	0	10	4-20 mA	-	4
P4CG4001C005	G 1/2	0	7	0-10 V	-	4
P4CG4001C006	G 1/2	0	7	4-20 mA	-	4
P4CG4002C001	G 1/2	0	10	0-10 V	inclus	4
P4CG4002C002	G 1/2	0	10	4-20 mA	inclus	4
P4CG4002C005	G 1/2	0	7	0-10 V	inclus	4
P4CG4002C006	G 1/2	0	7	4-20 mA	inclus	4
P4CG4051C001 **	G 1/2	0	10	0-10 V	-	4
P4CG4051C002 **	G 1/2	0	10	4-20 mA	-	4
P4CN4001C001	1/2 NPT	0	10	0-10 V	-	4
P4CN4001C002	1/2 NPT	0	10	4-20 mA	-	4
P4CN4002C001	1/2 NPT	0	10	0-10 V	inclus	4
P4CN4002C002	1/2 NPT	0	10	4-20 mA	inclus	4

* Sortie pilote intégrée

** O2



LUCIFER® EPP4 COMFORT 1/4" & 1/2"

SCHÉMAS DES DIMENSIONS
GAMME EPP4 COMFORT 1/4"

Schéma 3

SCHÉMAS DES DIMENSIONS
GAMME EPP4 COMFORT 1/2"

Schéma 4

LUCIFER® EPP4 COMFORT 1/2"HP, 1" & 2"

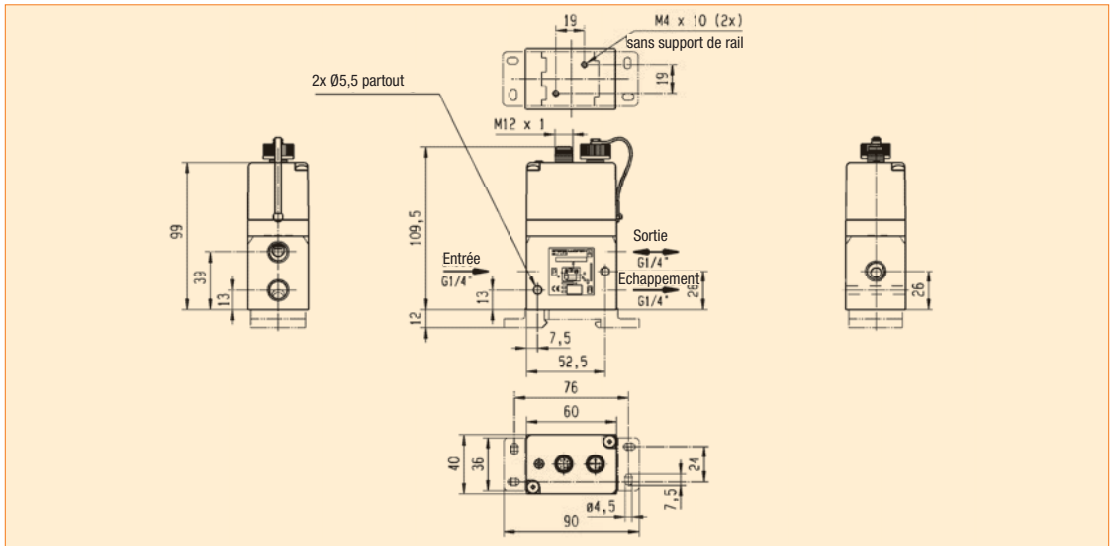
DONNÉES TECHNIQUES

Basic	1/4" 1/2"
Comfort	1/4" 1/2"
Comfort	1/2" HP 1" 2"
Comfort ATEX	1/2" 1" 2"

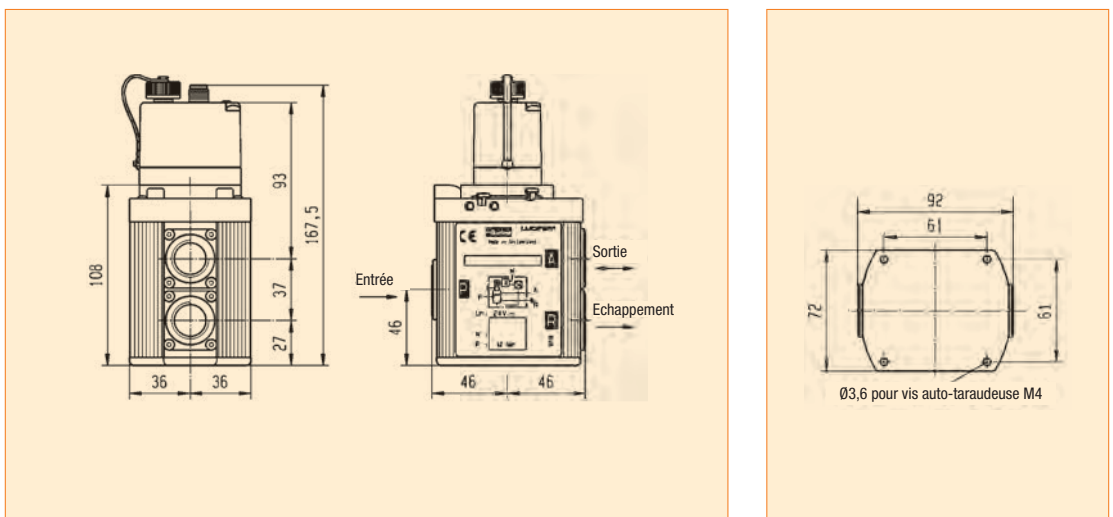
	Comfort 1/2" HP	Comfort 1"	Comfort 2"
Fluides :	Air et gaz neutres lubrifiés ou non lubrifiés - Filtration recommandée : 50 µm		
Plage de températures :	Température ambiante : de 0 °C à +50 °C Fluide : de 0 °C à +50 °C		
Plage de pression d'entrée : La pression d'entrée doit toujours être supérieure d'au moins 1 bar à la pression régulée.	De 1 à 21 bar	De 1 à 21 bar	De 1 à 12 bar
Plage de pression de sortie :	De 0,05 à 20 bar	De 0,05 à 20 bar	De 0,05 à 10 bar
Hysteresis :	≤ 100 mbar si entrée P ≤ 10 bar ≤ 200 mbar si entrée P > 10 bar		
Consommation d'air à signal de commande constant :	0		
Tension d'alimentation :	24V DC ± 15%		
Consommation électrique :	Max. 6 W avec 24 V CC et des variations constantes du signal de commande < 2 W sans variation du signal de commande		
Signal de commande :	Analogique 0 - 10 V Analogique 4 - 20 mA		
Signal du capteur de sortie :	Analogique 0 - 10 V Standard pour 0 - 10 bar ; réglable Analogique 4 - 20 mA Standard pour 0 - 10 bar ; réglable Numérique 0/24 V pour fonctions d'alarmes : Erreur de pression réglable (+/-) Délai réglable sur MARCHÉ Délai réglable sur ARRÊT Logique réglable (+/-)		
Débit max. :	150 m³/h	1 000 m³/h	2 700 m³/h
Temps de réaction indicatif : Remplissage de 2 à 8 bar : Vidage de 8 à 2 bar :	Avec un volume de 330 cm³ à la sortie du régulateur		
	120 msec 190 msc	250 msec 400 msc	250 msec 400 msc
Position de sécurité :	En cas de défaillance du signal de commande ou si celui-ci est inférieur à 50 mV, la pression régulée chute automatiquement à une pression atmosphérique de 0 bar (pour des plages de pressions de 0 à 10 bar, 100 mV pour une plage de pressions supérieure à 10 bar). En cas de défaillance de la tension d'alimentation, la pression régulée est maintenue constante.		
Raccord électrique :	M12 - 8 broches ; alimentation / signal de commande avec connecteur mâle M12 - 5 broches ; communication avec connecteur mâle		
Durée de vie :	> 20 millions de variations de pas de signal de commande		
Position de montage :	Indifférente (position recommandée : verticale ; partie électronique vers le haut)		
Résistance aux vibrations :	30 g dans toutes les directions		
Degré de protection :	IP 65		
Assemblage :	Exempt de silicone		
Compatibilité électromagnétique : En conformité avec :	EN 61000-6-1: 2001 EN 61000-6-2: 2001 EN 61000-6-3: 2001 + A11 édition 2004 (01/07/07) EN 61000-6-4: 2001		
Instructions d'installation et de réglage :	Voir notre document "408 193" ainsi que l'annexe fournie avec le produit.		

Remarque : Parker se réserve le droit de modifier les spécifications sans avis préalable.

LUCIFER® EPP4 COMFORT 1/2"HP, 1" & 2"

COURBES DE DÉBIT



Courbe de débit 1/2"HP

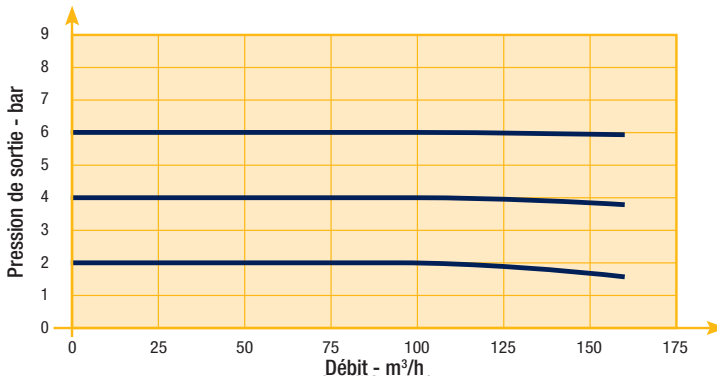

Courbe de débit 1"

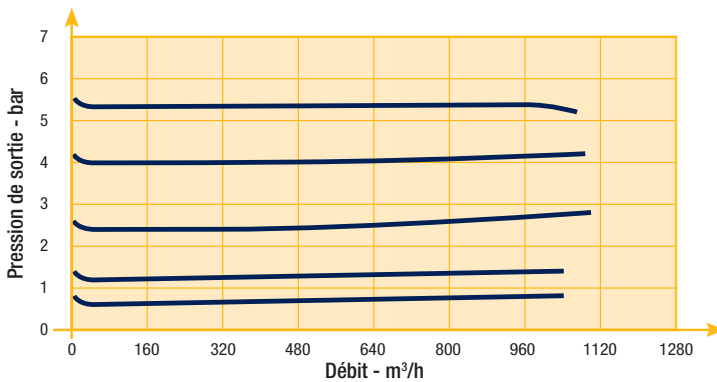

Courbe de débit 2"

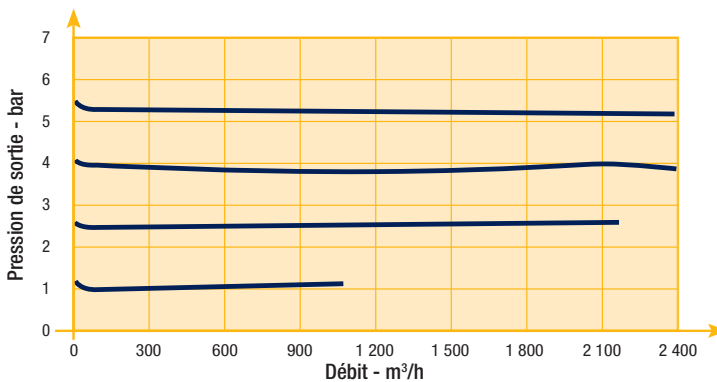

LUCIFER® EPP4 COMFORT 1/2"HP

RÉFÉRENCES

Codes	Raccord	Pression d'entrée maximale (bar)	Plage de pression (bar)		Signal de commande (voir options)	Numéro de schéma
P4CG4101D001	G1/2	15	0	12	0-10 V	5
P4CG4201D005	G1/2	21	0	16	0-10 V	6
P4CG4201D003	G1/2	21	0	20	0-10 V	6
P4CG4201D004	G1/2	21	0	20	4-20 mA	6

D'autres réglages spécifiques ou spécialisations sont disponibles. Veuillez nous contacter.



LUCIFER® EPP4 COMFORT 1/2"HP

SCHÉMAS DES DIMENSIONS



Schéma 5



Schéma 6

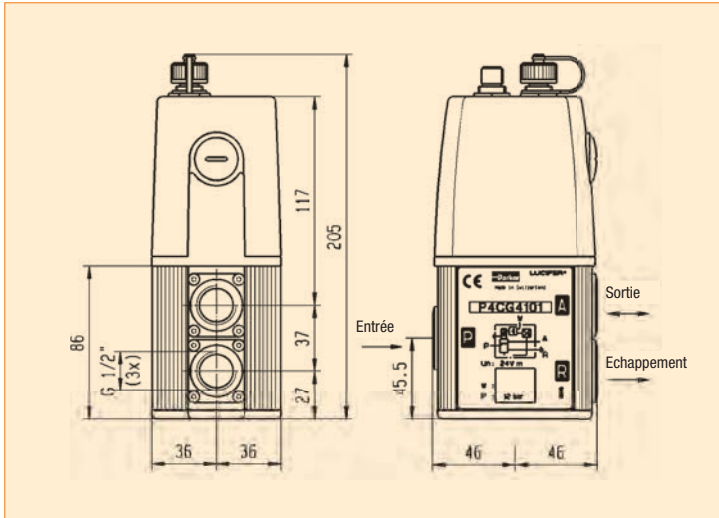

LUCIFER® EPP4 COMFORT 1" & 2"

RÉFÉRENCES

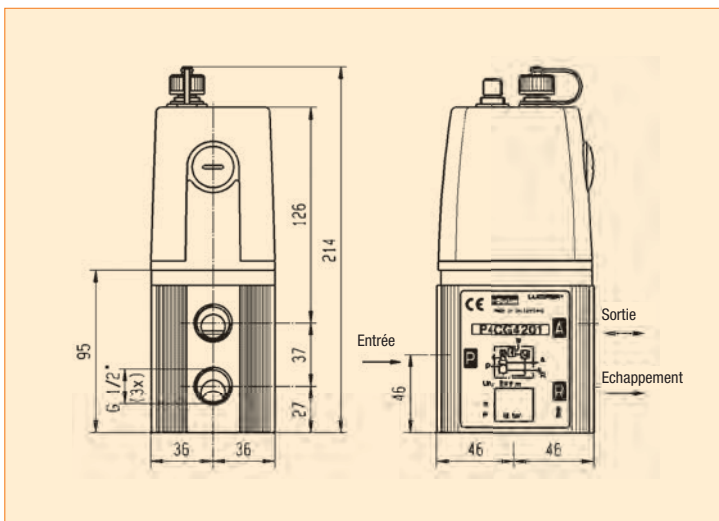
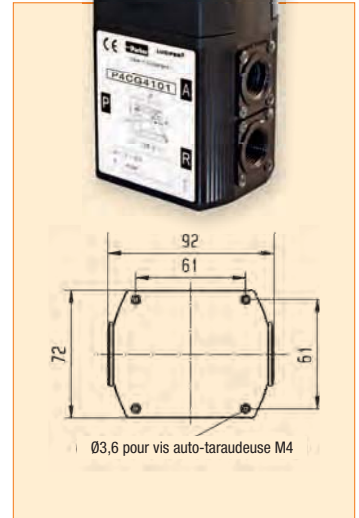
Codes	Raccord	Pression d'entrée maximale (bar)	Plage de pression (bar)		Signal de commande (voir options)	Numéro de schéma
P4CG6101C009	G1	12	0	3.5	4-20 mA	7
P4CG6101C011	G1	12	0	5.0	0-10 V	7
P4CG6101C010	G1	12	0	6.0	4-20 mA	7
P4CG6101C001	G1	12	0	10	0-10 V	7
P4CG6101C002	G1	12	0	10	4-20 mA	7
P4CG6201D001	G1	21	0	12	-	7
P4CG6201D003	G1	21	0	20	0-10 V	7
P4CG9101C012	G2	12	0	4.0	4-20 mA	8
P4CG9101C010	G2	12	0	6.0	4-20 mA	8
P4CG9101C001	G2	12	0	10	0-10 V	8
P4CG9101C002	G2	12	0	10	4-20 mA	8

D'autres réglages spécifiques ou spécialisations sont disponibles. Veuillez nous contacter.

LUCIFER® EPP4 COMFORT 1" & 2"

SCHÉMAS DES DIMENSIONS
GAMME EPP4 COMFORT 1"

Schéma 7

SCHÉMAS DES DIMENSIONS
GAMME EPP4 COMFORT 2"

Schéma 8

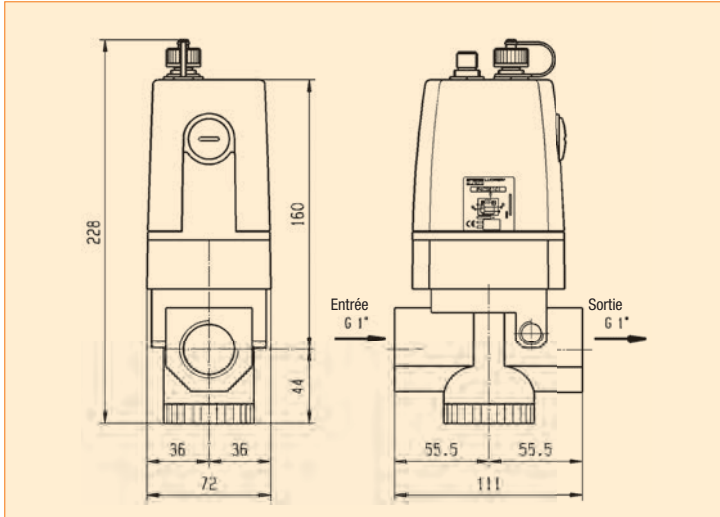

LUCIFER® EPP4 COMFORT 1/2", 1" & 2" ATEX

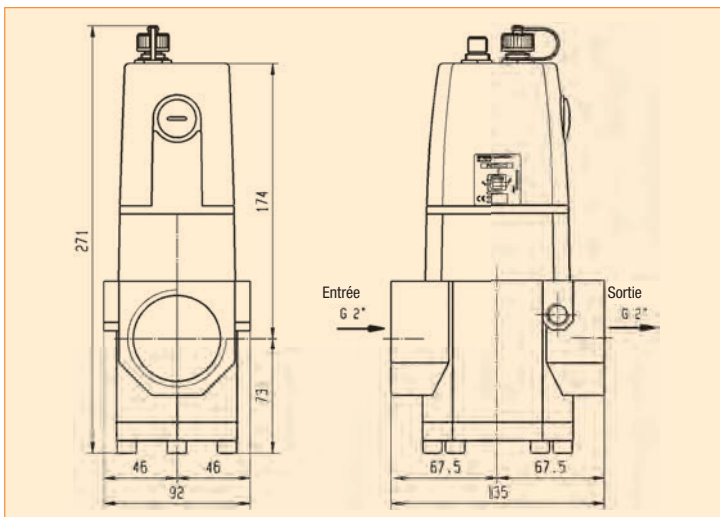

Basic	1/4" 1/2"
Comfort	1/4" 1/2"
Comfort	1/2" HP 1" 2"
Comfort ATEX	1/2" 1" 2"

DONNÉES TECHNIQUES

	Comfort 1/2" ATEX	Comfort 1" ATEX	Comfort 2" ATEX
Fluides :	Air et gaz neutres lubrifiés ou non lubrifiés - Filtration recommandée : 50 µm		
Plage de températures :	Température ambiante : de 0 °C à +50 °C Fluide : de 0 °C à +50 °C		
Plage de pression d'entrée : La pression d'entrée doit toujours être supérieure d'au moins 1 bar à la pression régulée.	Plage de pressions d'entrée : de 1 à 12 bar		
Plage de pression de sortie :	Plage de pressions de sortie : de 0,05 à 10 bar		
Hysteresis :	≤ 100 mbar		
Consommation d'air à signal de commande constant :	0		
Certification ATEX :	Ex II 3 G/D Ex nA IIC T4 Gc Ex tc IIIB T130°C Dc		
Tension d'alimentation :	24V DC ± 15 %		
Consommation électrique :	Max. 6 W avec 24 V CC et des variations constantes du signal de commande < 2 W sans variation du signal de commande		
Signal de commande :	Analogique 0 - 10 V Analogique 4 - 20 mA		
Signal du capteur de sortie :	Analogique 0 - 10 V Standard pour 0 - 10 bar ; réglable Analogique 4 - 20 mA Standard pour 0 - 10 bar ; réglable		
		Numérique 0/24 V pour fonctions d'alarmes : Erreur de pression réglable (+/-) Délai réglable sur MARCHÉ Délai réglable sur ARRÊT Logique réglable (+/-)	
Débit max. :	150 m³/h	1 000 m³/h	2 700 m³/h
Temps de réaction indicatif : Remplissage de 2 à 8 bar : Vidage de 8 à 2 bar :	Avec un volume de 330 cm³ à la sortie du régulateur		
	120 msec 190 msc	250 msec 400 msc	250 msec 400 msc
Position de sécurité :	En cas de défaillance du signal de commande ou si celui-ci est inférieur à 50 mV, la pression régulée chute automatiquement à une pression atmosphérique de 0 bar (pour des plages de pressions de 0 à 10 bar, 100 mV pour une plage de pressions supérieure à 10 bar). En cas de défaillance de la tension d'alimentation, la pression régulée est maintenue constante.		
Raccord électrique :	M12 - 8 broches ; alimentation / signal de commande avec connecteur mâle M12 - 5 broches ; communication avec connecteur mâle		
Durée de vie :	> 20 millions de variations de pas de signal de commande		
Position de montage :	Indifférente (position recommandée : verticale ; partie électronique vers le haut)		
Résistance aux vibrations :	30 g dans toutes les directions		
Degré de protection :	IP 54		
Assemblage :	Exempt de silicone		
Compatibilité électromagnétique : En conformité avec :	EN 61000-6-1: 2001 EN 61000-6-2: 2001 EN 61000-6-3: 2001 + A11 Edition 2004 (01/07/07) EN 61000-6-4: 2001		
Instructions d'installation et de réglage :	Voir notre document "408 283" ainsi que l'annexe fournie avec le produit.		

Remarque : Parker se réserve le droit de modifier les spécifications sans avis préalable.

LUCIFER® EPP4 COMFORT 1/2", 1" & 2" ATEX



COURBES DE DÉBIT



Courbe de débit 1/2"

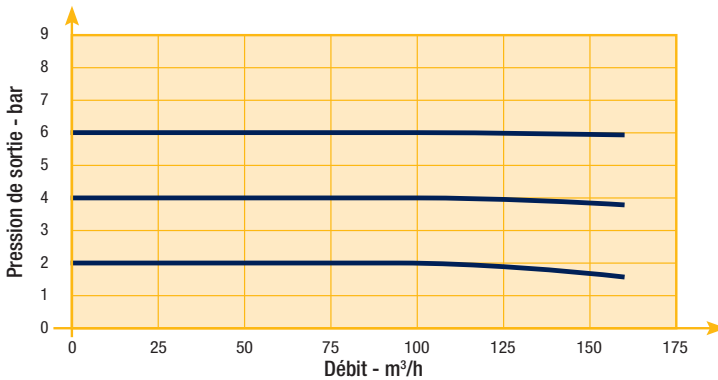

Courbe de débit 1"

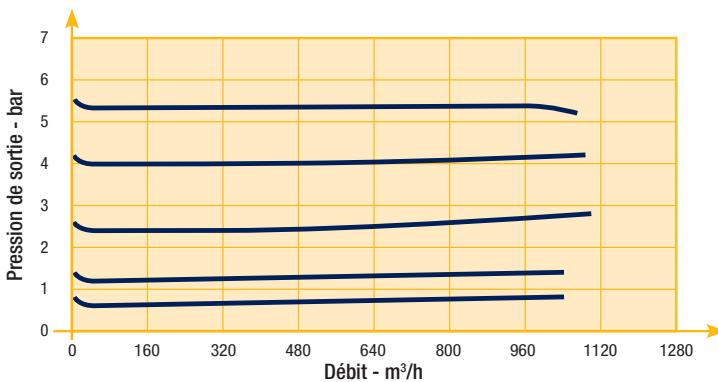

Courbe de débit 2"

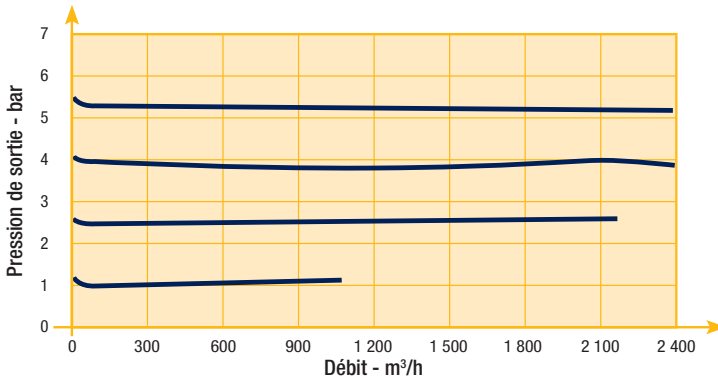



RÉFÉRENCES

Codes	Raccord	Pression d'entrée maximale (bar)	Plage de pression (bar)		Signal de commande (voir options)	Numéro de schéma
P4CG4461C001	G1/2	12	0	10	0-10 V	9
P4CG4461C002	G1/2	12	0	10	4-20 mA	9
P4CG4465C001 **	G1/2	12	0	10	0-10 V	9
P4CG4465C002 **	G1/2	12	0	10	4-20 mA	9

** O2

D'autres réglages spécifiques ou spécialisations sont disponibles. Veuillez nous contacter.



LUCIFER® EPP4 COMFORT 1/2" ATEX



SCHÉMAS DES DIMENSIONS



Schéma 9

LUCIFER® EPP4 COMFORT 1" & 2" ATEX

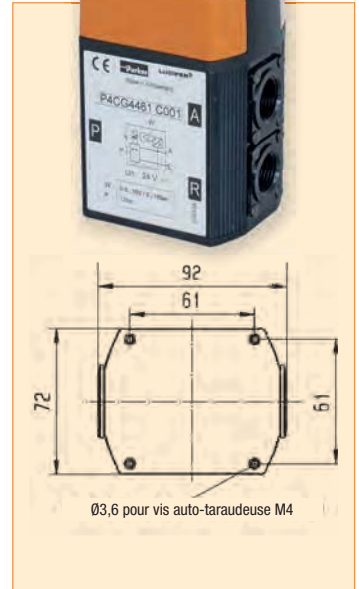
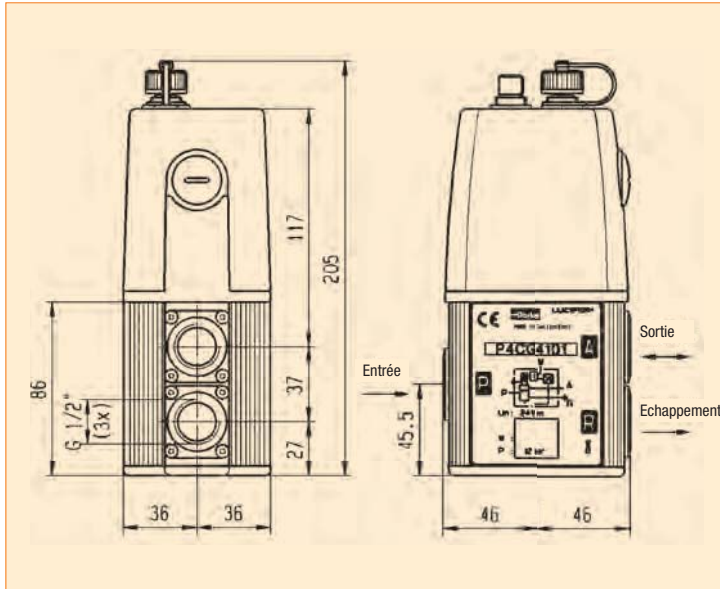

RÉFÉRENCES

Codes	Raccord	Pression d'entrée maximale (bar)	Plage de pression (bar)		Signal de commande (voir options)	Numéro de schéma
P4CG6161C001	G1	12	0	10	0-10 V	11
P4CG6161C002	G1	12	0	10	4-20 mA	11
P4CG9161C001	G2	12	0	10	0-10 V	12
P4CG9161C002	G2	12	0	10	4-20 mA	12

D'autres réglages spécifiques ou spécialisations sont disponibles. Veuillez nous contacter.

LUCIFER® EPP4 COMFORT 1" & 2" ATEX



SCHÉMAS DES DIMENSIONS GAMME EPP4 COMFORT 1"



Schéma 11

SCHÉMAS DES DIMENSIONS GAMME EPP4 COMFORT 2"

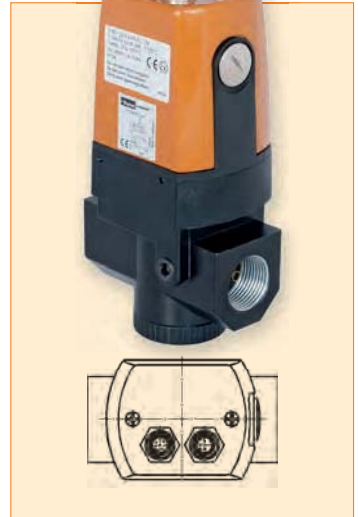
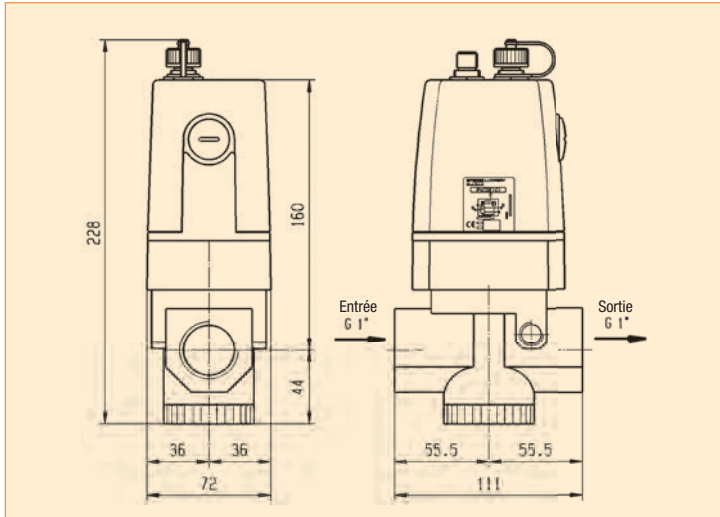

Schéma 12

LUCIFER® EPP4
ACCESSOIRES

SUPPORTS DE MONTAGE
POUR EPP4 1/4" BASIC / COMFORT

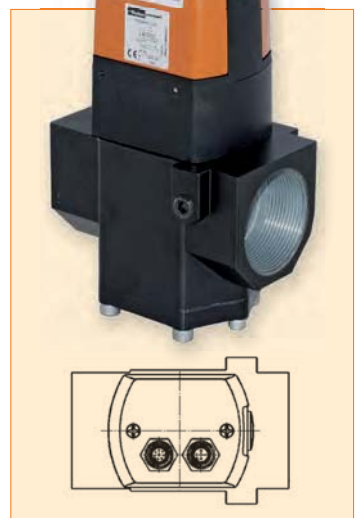
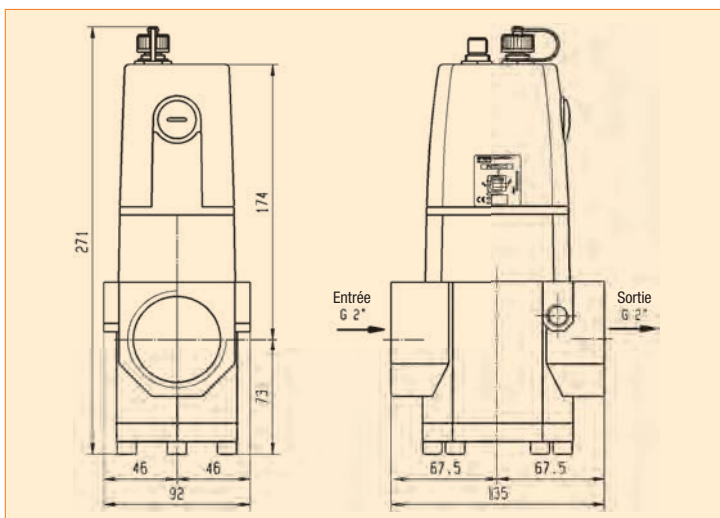

Ce support de montage est livré de manière standard avec tous les EPP4 1/4".

LUCIFER® EPP4 ACCESSOIRES

SUPPORTS DE MONTAGE POUR EPP4 1/2" BASIC / COMFORT

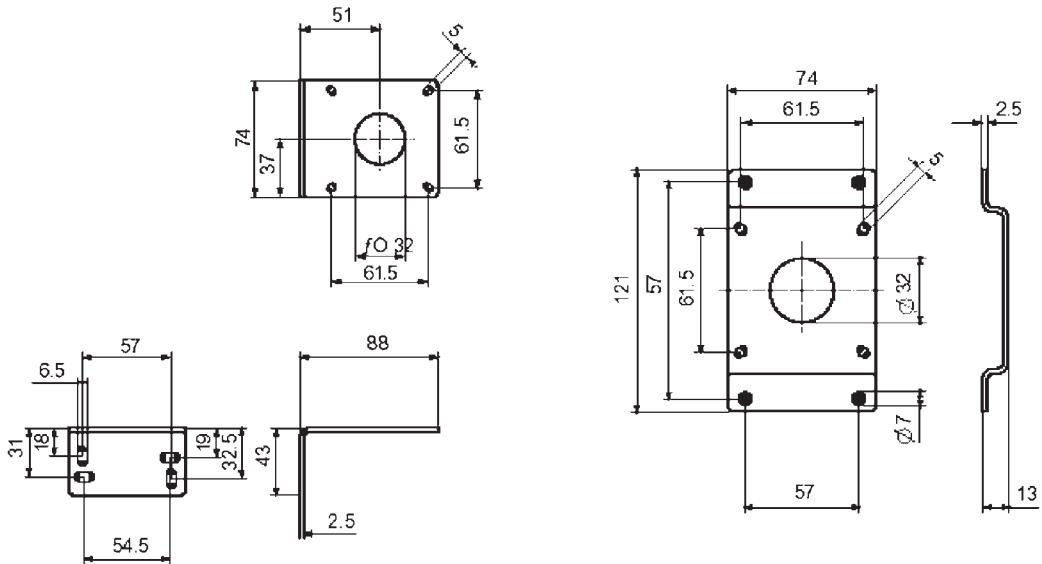

Référence de commande 491367



Référence de commande 491366

LUCIFER® EPP4 ACCESSOIRES

CÂBLE D'ALIMENTATION/ SIGNAL DE COMMANDE POUR VERSIONS BASIC ET COMFORT

Câble pour Basic EPP4

- Câble de 2 m avec connecteur M12 droit moulé à 4 pôles

Référence de commande **P8L-MC04A2A-M12**



Câble pour Comfort EPP4

- Câble de 2 m avec connecteur M12 droit moulé à 8 pôles

Référence de commande **496796**



LUCIFER® EPP4 COMFORT ACCESSOIRES

calys LOGICIEL

Calys est un logiciel unique développé en interne pour configurer tous les paramètres de la gamme EPP4 Comfort.

Calys est une option de l'EPP4.

Un câble spécifique est requis pour la communication entre l'EPP4 et un PC.

Calys offre de nombreuses possibilités :

- Surveillance en temps réel (signal de commande, pression régulée, tension d'alimentation, etc.)
- Enregistrement des paramètres principaux (signal de commande, pression régulée, tension d'alimentation, etc.) dans un fichier Excel
- Etalonnage libre des entrées et des sorties
- Alarme réglable (positive/négative, limites de pression, délais)
- Fichiers de configuration faciles à dupliquer
- Fichier d'aide complet et interactif
- Données dans 4 unités de pression différentes
- Menus dans 4 langues (anglais, allemand, français et italien)

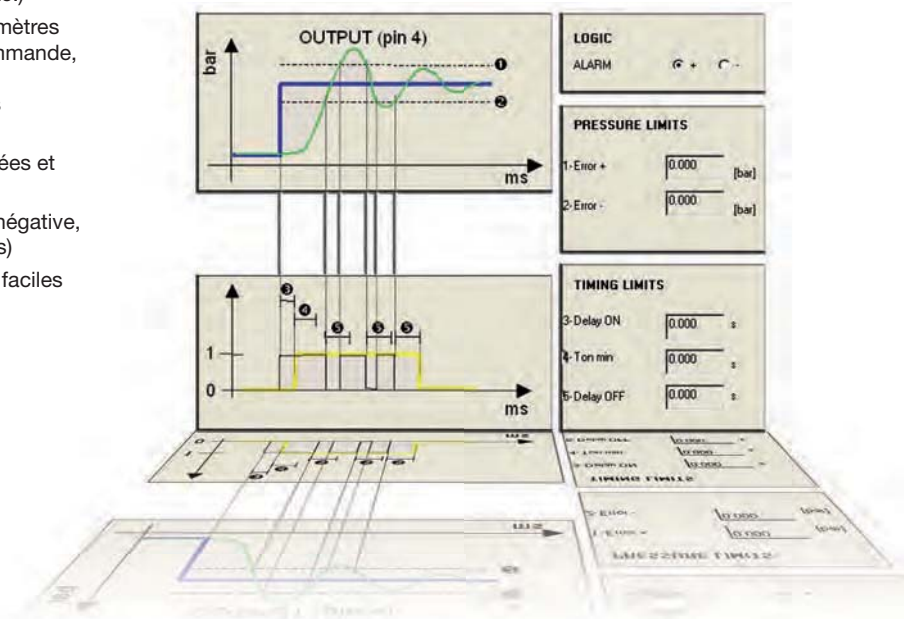

**Câble de communication spécifique
PC-EPP4 avec RS232 et connexion USB**

Référence de commande 496449

Cette option est uniquement destinée à une zone sécurisée.

Pour télécharger gratuitement le logiciel Calys, accédez à www.parker.com/FCDE/Support

LUCIFER® EPP4 COMFORT ACCESSOIRES

ECRAN DISTANT

Cette option inclut un écran distant et un câble de raccordement de 1,5 mètre.

Connecté au régulateur de pression, il permet un contrôle plus souple.

Ecran LED distant, compact et très facilement lisible :

- Echelles en bar et PSI
- Verrou de sécurité
- Câble de 1,5 m
- Supports de montage



Commandez l'écran distant sous la référence 496490

Cette option est uniquement destinée à une zone sécurisée.

KIT DE MONTAGE SUR PANNEAU

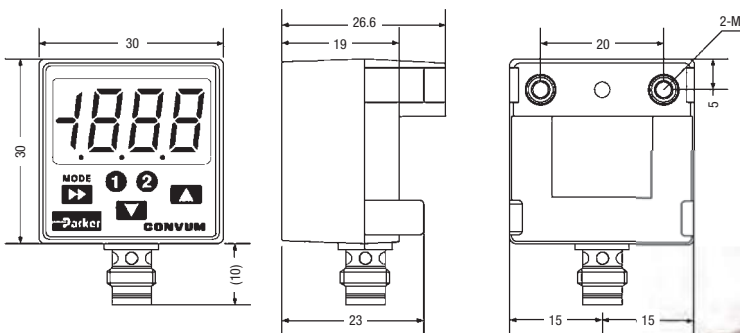

Commandez le kit de montage sur panneau sous la référence 496610

UNE GAMME COMPLÈTE DE BOBINES, BOÎTIERS ET PARTIES ÉLECTRIQUES POUR ÉLECTROVANNES



DÉFINITIONS

BOÎTIERS OU KITS D'ASSEMBLAGE DE BOBINE, BOBINES ET PARTIES ÉLECTRIQUES

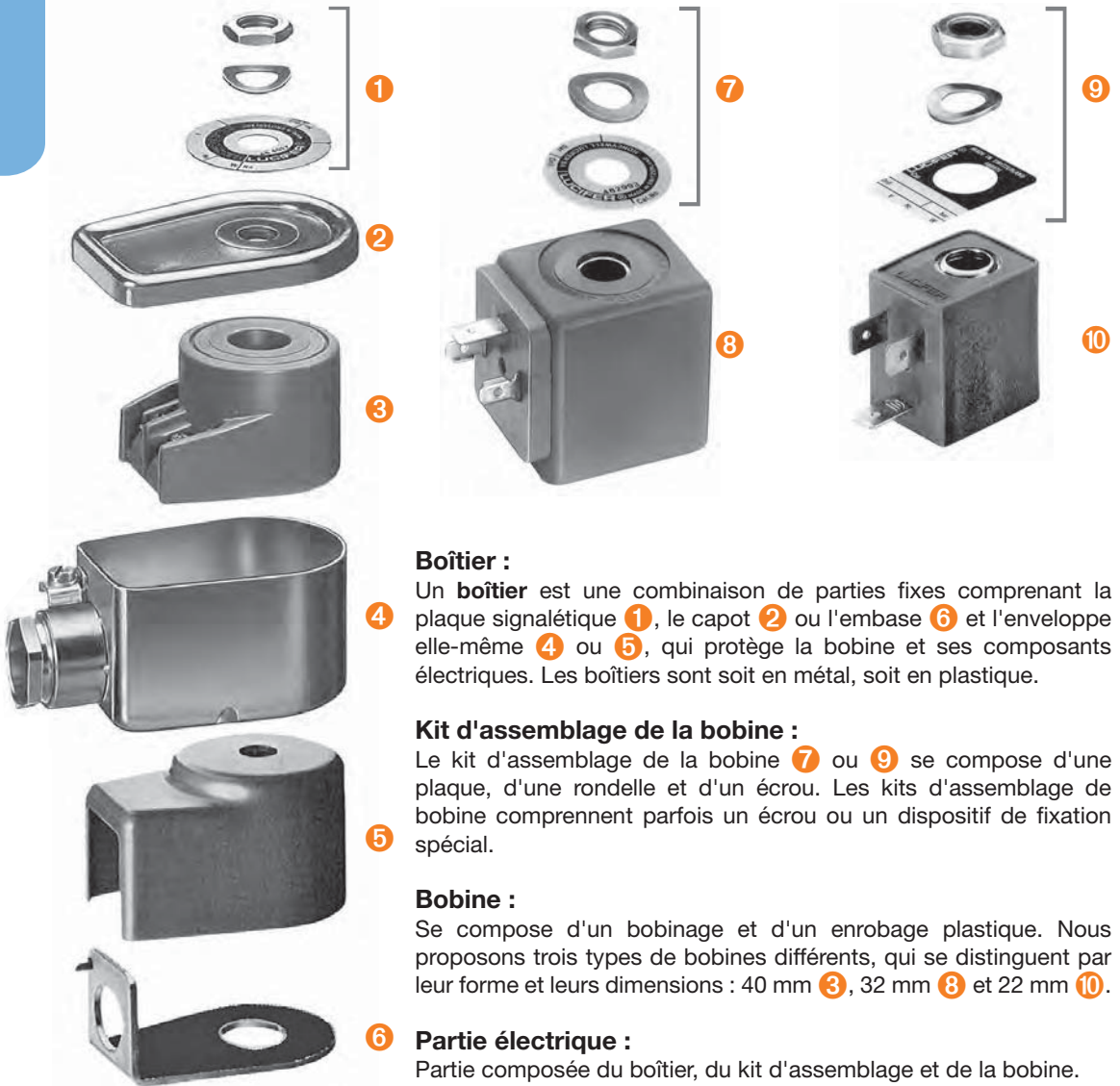

Boîtier :

Un **boîtier** est une combinaison de parties fixes comprenant la plaque signalétique **1**, le capot **2** ou l'embase **6** et l'enveloppe elle-même **4** ou **5**, qui protège la bobine et ses composants électriques. Les boîtiers sont soit en métal, soit en plastique.

Kit d'assemblage de la bobine :

Le kit d'assemblage de la bobine **7** ou **9** se compose d'une plaque, d'une rondelle et d'un écrou. Les kits d'assemblage de bobine comprennent parfois un écrou ou un dispositif de fixation spécial.

Bobine :

Se compose d'un bobinage et d'un enrobage plastique. Nous proposons trois types de bobines différents, qui se distinguent par leur forme et leurs dimensions : 40 mm **3**, 32 mm **8** et 22 mm **10**.

6 Partie électrique :

Partie composée du boîtier, du kit d'assemblage et de la bobine.

Attention :

Les bobines ou les parties électriques Lucifer® ne peuvent être alimentées que si elles sont montées sur une vanne afin d'éviter d'endommager le produit ou son proche environnement (risque de surchauffe, d'explosion, d'incendie, etc.).

SOMMAIRE

INTRODUCTION

Index par référence de bobine.....	446
Index par groupe électrique.....	448
Index pour les parties électriques antidéflagrantes.....	450
Liste des groupes électrique.....	451

BOBINES

Bobines pour connecteur à broches DIN.....	454
Bobines avec câbles volants.....	477
Bobines avec bornes à vis.....	482
Bobines avec connecteur ISO-DIN.....	488

PARTIES ÉLECTRIQUES ANTIDÉFLAGRANTES

Niveau de protection "nc AC".....	490
Niveau de protection "db".....	498
Niveau de protection "mb".....	499
Niveau de protection "db mb".....	504
Niveau de protection "eb".....	509
Niveau de protection "ia".....	513

BOÎTIERS.....	522
---------------	-----

ACCESSOIRES DE BOBINE.....	526
----------------------------	-----

ENVIRONNEMENTS EXPLOSIFS.....	528
-------------------------------	-----

ANNEXES POUR BOBINES

Tableau informatif pour les barrières IS.....	538
Tableau des codes tension pour les bobines et les parties électriques.....	540

INDEX PAR RÉFÉRENCE DE BOBINE

Référence de bobine	Groupe Électrique	Désignation	Puissance CC Pn (W)	Puissance CA Pn (W)	Température ambiante	UL	Indice de protection	Protection ATEX ou NEMA 4X (Gaz)	Page
481000	2.0/2.1	Bobine avec borne à vis, 40 mm	8,0	8,0	entre -40 °C et +50 °C	-	IP 44 à 67	-	482
481044	2.0/2.2	Bobine avec borne à vis haute puissance, 40 mm	-	14,0	entre -40 °C et +50 °C	-	IP 44 à 67	-	483
481180	1.1	Bobine pour connecter à broches DIN, 22 mm	5,0	4,0	entre -40 °C et +50 °C	-	IP65	-	461
481865	2.0/2.1	Bobine pour connecter à broches DIN, 32 mm	9,0	8,0	entre -40 °C et +50 °C	-	IP65	-	454
482605	1.1	Partie électrique enrobée antidéflagrante "mb", 32 mm	5,0	4,0	entre -40 °C et +65 °C	-	IP65	II 2 G Ex mb II T4 / T5	499
482606	1.1	Partie électrique enrobée antidéflagrante "mb", faible puissance, 32 mm	2,5	2,0	entre -40 °C et +65 °C	-	IP65	II 2 G Ex mb II T4 / T5	499
482730	3.0	Bobine pour connecter à broches DIN, puissance réduite, 32 mm	7,0	6,0	entre -40 °C et +50 °C	-	IP65	-	456
482740	6.0	Bobine pour connecter à broches DIN, faible puissance, 32 mm	1,6	-	entre -40 °C et +50 °C	-	IP65	-	457
482870.01	12.0	Partie électrique antidéflagrante à sécurité intrinsèque "ia", 50 mm	3,0	-	entre -40 °C et +65 °C	-	IP66	II 1 G Ex ia IIC T6	517
483270	11.0	Partie électrique résistante aux flammes "db", 50 mm	8,0	8,0	entre -40 °C et +80 °C	-	IP66	II 2 G Ex db IIC T4/T5/T6	498
483371	2.0/2.1	Partie électrique antidéflagrante à sécurité augmentée "eb", 50 mm	8,0	8,0	entre -40 °C et +65 °C	-	IP67	II 2 G Ex eb IIC T4	509
483510	2.0/2.1	Bobine pour connecter à broches DIN, 32 mm	-	9,0	entre -40 °C et +50 °C	-	IP65	-	454
483520	2.0/2.1	Bobine avec borne à vis, double fréquence, 40 mm	-	9,0	entre -40 °C et +50 °C	-	IP 44 à 67	-	482
483541	14.1	Bobine avec borne à vis, haute température, haute puissance, 40 mm	20,0	20,0	entre -40 °C et +50 °C	-	IP 44 à 67	-	485
483580.01	7.0	Partie électrique antidéflagrante à sécurité intrinsèque "ia", 32 mm	3,0	-	entre -40 °C et +55 °C	-	IP65	II 1 G Ex ia IIC T6	513
483590	1.1	Bobine pour connecter à broches DIN, double fréquence, 22 mm	-	3,0	entre -40 °C et +50 °C	-	IP65	-	463
483764	14.2	Bobine pour connecter à broches DIN, 32 mm, UL	-	9,0	entre -40 °C et +50 °C	●	IP65	-	459
483816	2.2	Bobine pour connecter à broches DIN pour valves à commutation rapide 32 mm	14,0	14,0	entre -40 °C et +50 °C	-	IP65	-	460
483824	14.1	Bobine avec borne à vis, haute température, haute puissance, 40 mm	19,0	19,0	entre -40 °C et +50 °C	-	IP 44 à 67	-	485
484990	4.0	Bobine avec borne à vis, bistable, pour les applications par impulsion, 40 mm	-	11,0	entre -40 °C et +50 °C	-	IP44	-	487
485100	2.0/2.1	Bobine avec borne à vis, haute température, 40 mm	8,0	8,0	entre -40 °C et +50 °C	-	IP 44 à 67	-	484
485400	4.0	Bobine avec borne à vis, bistable, pour les applications par impulsion, 40 mm	13,0	-	entre -40 °C et +50 °C	-	IP44	-	487
486265	2.0/2.2	Bobine avec borne à vis, haute température, haute puissance, 40 mm	14,0	14,0	entre -40 °C et +50 °C	-	IP 44 à 67	-	484
488143	1.1	Bobine pour connecter à broches DIN, double fréquence, 22 mm	-	2,5	entre -40 °C et +50 °C	-	IP65	-	464
488553	2.0/2.1	Bobine avec borne à vis, double fréquence, classe H, 40 mm	-	9,0	entre -40 °C et +50 °C	-	IP 44 à 67	-	486
488650.01	7.0	Partie électrique antidéflagrante à sécurité intrinsèque "ia", 50 mm	0,3 à 3,0	-	entre -40 °C et +65 °C	-	IP66	II 1 G Ex ia IIC T6	518
488660.01	7.0	Partie électrique antidéflagrante à sécurité intrinsèque "ia", 50 mm	3,0	-	entre -40 °C et +65 °C	-	IP67	II 1 G Ex ia IIC T6	519
488670.01	7.0	Partie électrique antidéflagrante à sécurité intrinsèque "ia", 50 mm	0,3 à 3,0	-	entre -40 °C et +65 °C	-	IP65	II 1 G Ex ia IIC T6	520
488980	1.1	Bobine pour connecter à broches DIN, faible puissance, 22 mm	2,5	2,0	entre -40 °C et +50 °C	-	IP65	-	461
490885	7.0	Partie électrique antidéflagrante à sécurité intrinsèque "NEMA", 50 mm	3,0	-	entre -40 °C et +60 °C	-	NEMA 4 - 4X	Cl. I, Div.I, Gr. A, B, C, D	518
490890	7.0	Partie électrique antidéflagrante à sécurité intrinsèque "NEMA", 50 mm	3,0	-	entre -40 °C et +60 °C	-	NEMA 4 - 4X	Cl. I, Div.I, Gr. A, B, C, D	519
491514	2.0/2.1	Bobine pour connecter à broches DIN, 32 mm, UL	-	11,0	entre -40 °C et +50 °C	●	IP65	-	458
492070	2.0/2.1	Partie électrique enrobée antidéflagrante "mb", avec boîtier métallique étanche, 50 mm	8,0	9,0	entre -40 °C et +65 °C	-	IP67	II 2 G Ex mb II T4 / T5	501
492190	2.0/2.1	Partie électrique enrobée, antidéflagrante, à sécurité augmentée "eb", 50 mm	9,0	11,0	entre -40 °C et +75 °C	-	IP66	II 2 G Ex eb mb II T3 / T4	512
492210	9.0	Partie électrique enrobée, antidéflagrante, à sécurité augmentée "eb", "Booster", 50 mm	1,0 à 1,8	-	entre -40 °C et +75 °C	-	IP66	II 2 G Ex eb mb II T5 / T6	511
492310	10.1	Partie électrique enrobée, antidéflagrante, à sécurité augmentée "eb", 50 mm	6,0	6,0	entre -40 °C et +75 °C	-	IP66	II 2 G Ex eb mb II T4 / T5	510
492335	12.0	Partie électrique antidéflagrante à sécurité intrinsèque "NEMA", 50 mm	3,0	-	entre -40 °C et +60 °C	-	NEMA 4 - 4X	Cl. I, Div.I, Gr. A, B, C, D	517
492425	2.0/2.2	Bobine pour connecter à broches DIN, haute température, 32 mm	14,0	14,0	entre -40 °C et +50 °C	-	IP65	-	455
492453	2.0/2.1	Bobine pour connecter à broches DIN, haute température, 32 mm	9,0	8,0	entre -40 °C et +50 °C	-	IP65	-	455
492670	2.0/2.1	Partie électrique enrobée antidéflagrante "mb", 32 mm	9,0	8,0	entre -40 °C et +50 °C	-	IP65	II 2 G Ex mb II T4	500
492912	1.1	Bobine pour connecter à broches DIN, 22 mm, UL	4,0	3,0	entre -40 °C et +50 °C	●	IP65	-	462
492965.01	9.0	Partie électrique antidéflagrante à sécurité intrinsèque "ia", "Booster", 50 mm	0,3 à 2,3	-	entre -40 °C et +65 °C	-	IP66	II 1 G Ex ia IIC T6	516
493640	2.0/2.1	Partie électrique enrobée résistante aux flammes "db mb", double fréquence	8,0	8,0	entre -40 °C et +75 °C	-	IP65	II 2 G Ex db mb IIC T4	508
494040	2.0/2.1	Partie électrique antidéflagrante à sécurité augmentée "eb", 50 mm	8,0	8,0	entre -40 °C et +90 °C	-	IP67	II 2 G Ex eb IIC T3 / T4	509
495294	13.0	Bobine avec connecteur ISO-DIN, 12-24 V CC pour les applications dans le domaine du transport, 32 mm	9,0	-	entre -40 °C et +120 °C	-	IP69K	-	488
495865	1.1	Partie électrique antidéflagrante "nc AC", faible puissance, 22 mm	2,5	2,0	entre -40 °C et +50 °C	-	IP65	II 3 G Ex nc AC IIC T5	490
495870	2.0/2.1	Partie électrique antidéflagrante "nc AC", 32 mm	9,0	8,0	entre -40 °C et +50 °C	-	IP65	II 3 G Ex nc AC IIC T3 / T4	492

INDEX PAR RÉFÉRENCE DE BOBINE

Référence de bobine	Groupe Électrique	Désignation	Puissance CC Pn (W)	Puissance CA Pn (W)	Température ambiante	UL	Indice de protection	Protection ATEX ou NEMA 4X (Gaz)	Page
495875	2.0/2.1	Partie électrique antidéflagrante "nc AC", 32 mm	7,0	6,0	entre -40 °C et +50 °C	-	IP65	II 3 G Ex nc AC IIC T3 / T4	494
495880	2.0/2.2	Partie électrique antidéflagrante "nc AC", 32 mm	14,0	14,0	entre -40 °C et +50 °C	-	IP65	II 3 G Ex NC AC IIC T3	495
495900	6.0	Partie électrique enrobée, résistante aux flammes "db mb", faible puissance, 37 mm	2,0	2,5	entre -40 °C et +65 °C	-	IP67	II 2 G Ex DB MB IIC T4 / T5 / T6	504
495905	2.0/2.1	Partie électrique enrobée résistante aux flammes "db mb", 37 mm	8,0	8,0	entre -40 °C et +65 °C	-	IP67	II 2 G Ex DB MB IIC T4	505
495910	8.0	Partie électrique antidéflagrante à sécurité intrinsèque "ia", "Booster", 37 mm	0,3 à 1,2	-	entre -40 °C et +80 °C	-	IP67	II 1 G Ex IA IIC T6 / T5 / T4	514
495915	4.0	Partie électrique antidéflagrante à sécurité augmentée "nc AC", 50 mm	13,0	11,0	entre -40 °C et +65 °C	-	IP67	II 3 G Ex NC AC IIC T3	496
496081	2.0/2.1	Bobine avec câbles volants, IP 67, 32 mm	9,0	9,0	entre -40 °C et +50 °C	-	IP67	-	480
496082	2.0/2.2	Bobine avec câbles volants, IP 67, 32 mm, UL	16,0	13,0 à 14,0	entre -40 °C et +120 °C	●	IP67	-	481
496110	2.0/2.1	Partie électrique antidéflagrante "nc AC", 32 mm	-	9,0	entre -40 °C et +50 °C	-	IP65	II 3 G Ex NC AC IIC T3 / T4	492
496125	6.0	Partie électrique antidéflagrante "nc AC", faible puissance, 32 mm	1,6	-	entre -40 °C et +50 °C	-	IP65	II 3 G Ex NC AC IIC T5 / T6	493
496131	1.2	Bobine pour connecteur à broches DIN, double fréquence, 22 mm	3,0	3,0	entre -40 °C et +50 °C	-	IP65	-	465
496155	2.0/2.2	Partie électrique antidéflagrante à sécurité augmentée "nc AC", 50 mm	14,0	14,0	entre -40 °C et +65 °C	-	IP67	II 3 G Ex NC AC IIC T3	497
496193	13.0	Bobine avec connecteur ISO-DIN, 12-24 V CC pour les applications dans le domaine du transport, 32 mm	9,0	-	entre -40 °C et +120 °C	-	IP69K	-	488
496482	1.2	Bobine pour connecteur à broches DIN, double fréquence, 22 mm	3,0	3,0	entre -40 °C et +50 °C	-	IP65	-	466
496555	10.2	Partie électrique enrobée résistante aux flammes "db mb", 37 mm	6,0	6,0	entre -40 °C et +65 °C	-	IP67	II 2 G Ex DB MB IIC T4 / T5 / T6	506
496560	10.1	Partie électrique enrobée résistante aux flammes "db mb", 37 mm	8,0	8,0	entre -40 °C et +65 °C	-	IP67	II 2 G Ex DB MB IIC T4	506
496565	9.0	Partie électrique antidéflagrante à sécurité intrinsèque "ia", "Booster", 37 mm	0,77 à 2,58	-	entre -40 °C et +80 °C	-	IP67	II 1 G Ex IA IIC T6 / T5 / T4	515
496637	1.2	Partie électrique antidéflagrante "nc AC", double fréquence, 22 mm	3,0	3,0	entre -40 °C et +50 °C	-	IP65	II 3 D Ex TC IIC T 95°C	491
496700	10.2	Partie électrique enrobée résistante aux flammes "db mb", 37 mm	6,0	6,0	entre -40 °C et +65 °C	-	IP67	II 2 G Ex DB MB IIC T4 / T5 / T6	507
496800	10.1	Partie électrique enrobée résistante aux flammes "db mb", 37 mm	8,0	8,0	entre -40 °C et +65 °C	-	IP67	II 2 G Ex DB MB IIC T4	507
496895	10.1	Bobine pour connecteur à broches DIN (pour l'huile et le gaz), 37 mm	8,0	8,0	entre -40 °C et +50 °C	-	IP65	-	476
D4	24.0	Bobine pour connecteur à broches DIN, 32 mm, UL	16,0	13,0	entre -40 °C et +50 °C	●	IP65	-	554
D5	24.0	Bobine pour connecteur à broches DIN, 32 mm	9,0	8,0	entre -40 °C et +50 °C	-	IP65	-	555
HZ10	2.0/2.1	Partie électrique enrobée antidéflagrante "mb", double fréquence	8,0	8,0	entre -40 °C et +50 °C	-	IP65	II 2 G Ex MB II T4 / T5	502
HZ11	2.0/2.2	Partie électrique enrobée antidéflagrante "mb", double fréquence	14,0	14,0	entre -40 °C et +50 °C	-	IP65	II 2 G Ex MB II T4 / T5	503
JB14	21.0	Bobine pour connecteur à broches DIN	16,0	-	entre -10 °C et +50 °C	-	IP65	-	470
JB16	21.0	Bobine pour connecteur à broches DIN	-	14,0	entre -10 °C et +50 °C	-	IP65	-	470
KH09	22.0	Bobine pour connecteur à broches DIN	-	9,0	entre -10 °C et +80 °C	-	IP65	-	471
KT09	22.0	Bobine pour connecteur à broches DIN	-	9,0	entre -10 °C et +50 °C	-	IP65	-	471
KT10	22.0	Bobine pour connecteur à broches DIN	10,0	-	entre -10 °C et +50 °C	-	IP65	-	471
LA	24.0	Bobine avec câbles volants, IP 67, 32 mm	9,0	9,0	entre -10 °C et +50 °C	-	IP67	-	478
LB-LC	24.0	Bobine avec câbles volants, 32 mm, UL	16,0	13,0 à 14,0	entre -10 °C et +50 °C	●	IP67	-	479
WB4.5	1.3	Bobine pour connecteur à broches DIN, 22 mm	-	4,5	entre -10 °C et +50 °C	-	IP65	-	467
WB4.5 UR	1.3	Bobine pour connecteur à broches DIN, 22 mm	-	4,5	entre -10 °C et +50 °C	●	IP65	-	467
WB5.0	1.3	Bobine pour connecteur à broches DIN, 22 mm	5,0	-	entre -10 °C et +50 °C	-	IP65	-	467
WB5.0 cURus	1.3	Bobine pour connecteur à broches DIN, 22 mm	5,0	-	entre -10 °C et +50 °C	●	IP65	-	467
WB8.0	1.3	Bobine pour connecteur à broches DIN, 22 mm	-	8,0	entre -10 °C et +50 °C	-	IP65	-	467
XS03	24.0	Bobine pour connecteur à broches DIN, 32 mm	-	9,0	entre -40 °C et +50 °C	-	IP65	-	475
XT09	23.0	Bobine pour connecteur à broches DIN	-	9,0	entre -10 °C et +50 °C	-	IP54	-	472
YB09	20.1	Bobine avec câbles volants, IP 67, UL pour CA	-	9,0	entre -10 °C et +50 °C	●	IP67	-	477
YB12	20.1	Bobine avec câbles volants, IP 67	12,0	-	entre -10 °C et +50 °C	-	IP67	-	477
ZB09	20.0	Bobine pour connecteur à broches DIN, UL pour CA	-	9,0	entre -10 °C et +50 °C	●	IP65	-	468
ZB12	20.0	Bobine pour connecteur à broches DIN	12,0	-	entre -10 °C et +50 °C	-	IP65	-	468
ZB14	20.2	Bobine pour connecteur à broches DIN, haute puissance, haute température	-	14,0	entre -10 °C et +50 °C	-	IP65	-	469
ZB16	20.2	Bobine pour connecteur à broches DIN, haute puissance, haute température	16,0	-	entre -10 °C et +50 °C	-	IP65	-	469
ZH14	20.2	Bobine pour connecteur à broches DIN, haute puissance, haute température	-	14,0	entre -10 °C et +80 °C	-	IP65	-	469
ZH16	20.2	Bobine pour connecteur à broches DIN, haute puissance, haute température	16,0	-	entre -10 °C et +80 °C	-	IP65	-	469

INDEX PAR GROUPE ÉLECTRIQUE

Groupe Électrique	Référence de bobine	Désignation	Puissance CC Pn (W)	Puissance CA Pn (W)	Température ambiante	UL	Indice de protection	Protection ATEX ou NEMA 4X (Gaz)	Page
1.1	488980	Bobine pour connecteur à broches DIN, faible puissance, 22 mm	2,5	2,0	entre -40 °C et +50 °C	-	IP65	-	461
1.1	492912	Bobine pour connecteur à broches DIN, UL 22 mm	4,0	3,0	entre -40 °C et +50 °C	●	IP65	-	462
1.1	481180	Bobine pour connecteur à broches DIN, 22 mm	5,0	4,0	entre -40 °C et +50 °C	-	IP65	-	462
1.1	488143	Bobine pour connecteur à broches DIN, double fréquence, 22 mm	-	2,5	entre -40 °C et +50 °C	-	IP65	-	464
1.1	483590	Bobine pour connecteur à broches DIN, double fréquence, 22 mm	-	3,0	entre -40 °C et +50 °C	-	IP65	-	463
1.1	495865	Partie électrique antidéflagrante "nc AC", faible puissance, 22 mm	2,5	2,0	entre -40 °C et +50 °C	-	IP65	II 3 G Ex nc AC IIC T5	490
1.1	482606	Partie électrique enrobée antidéflagrante "mb", faible puissance, 32 mm	2,5	2,0	entre -40 °C et +65 °C	-	IP65	II 2 G Ex mb II T4 / T5	499
1.1	482605	Partie électrique enrobée antidéflagrante "mb", 32 mm	5,0	4,0	entre -40 °C et +65 °C	-	IP65	II 2 G Ex mb II T4 / T5	499
1.2	496131	Bobine pour connecteur à broches DIN, double fréquence, 22 mm	3,0	3,0	entre -40 °C et +50 °C	-	IP65	-	465
1.2	496482	Bobine pour connecteur à broches DIN, bobine à double fréquence, 22 mm	3,0	3,0	entre -40 °C et +50 °C	-	IP65	-	466
1.2	496637	Partie électrique antidéflagrante "nc AC", 22 mm, double fréquence	3,0	3,0	entre -40 °C et +50 °C	-	IP65	II 3 D Ex tc IIC T 95°C	491
1.3	WB5.0	Bobine pour connecteur à broches DIN, 22 mm	5,0	-	entre -10 °C et +50 °C	-	IP65	-	467
1.3	WB5.0 cJ Rus	Bobine pour connecteur à broches DIN, 22 mm	5,0	-	entre -10 °C et +50 °C	●	IP65	-	467
1.3	WB4.5	Bobine pour connecteur à broches DIN, 22 mm	-	4,5	entre -10 °C et +50 °C	-	IP65	-	467
1.3	WB4.5 UR	Bobine pour connecteur à broches DIN, 22 mm	-	4,5	entre -10 °C et +50 °C	●	IP65	-	467
1.3	WB8.0	Bobine pour connecteur à broches DIN, 22 mm	-	8,0	entre -10 °C et +50 °C	-	IP65	-	467
2.0/2.1	481000	Bobine avec borne à vis, 40 mm	8,0	8,0	entre -40 °C et +50 °C	-	IP 44 à 67	-	482
2.0/2.1	485100	Bobine avec borne à vis, haute température, 40 mm	8,0	8,0	entre -40 °C et +50 °C	-	IP 44 à 67	-	484
2.0/2.1	481865	Bobine pour connecteur à broches DIN, 32 mm	9,0	8,0	entre -40 °C et +50 °C	-	IP65	-	454
2.0/2.1	492453	Bobine pour connecteur à broches DIN, haute température, 32 mm	9,0	8,0	entre -40 °C et +50 °C	-	IP65	-	455
2.0/2.1	496081	Bobine avec câbles volants, IP 67, 32 mm	9,0	9,0	entre -40 °C et +50 °C	-	IP67	-	480
2.0/2.2	496082	Bobine avec câbles volants, IP 67, 32 mm, UL	16,0	13,0 à 14,0	entre -40 °C et +120 °C	●	IP67	-	481
2.0/2.1	483510	Bobine pour connecteur à broches DIN, 32 mm	-	9,0	entre -40 °C et +50 °C	-	IP65	-	454
2.0/2.1	483520	Bobine avec borne à vis, double fréquence, 40 mm	-	9,0	entre -40 °C et +50 °C	-	IP 44 à 67	-	482
2.0/2.1	488553	Bobine avec borne à vis, double fréquence, classe H, 40 mm	-	9,0	entre -40 °C et +50 °C	-	IP 44 à 67	-	486
2.0/2.1	491514	Bobine pour connecteur à broches DIN, 32 mm, UL	-	11,0	entre -40 °C et +50 °C	●	IP65	-	458
2.0/2.1	495875	Partie électrique antidéflagrante "nc AC", 32 mm	7,0	6,0	entre -40 °C et +50 °C	-	IP65	II 3 G Ex nc AC IIC T3 / T4	494
2.0/2.1	495870	Partie électrique antidéflagrante "nc AC", 32 mm	9,0	8,0	entre -40 °C et +50 °C	-	IP65	II 3 G Ex nc AC IIC T3 / T4	492
2.0/2.1	496110	Partie électrique antidéflagrante "nc AC", 32 mm	-	9,0	entre -40 °C et +50 °C	-	IP65	II 3 G Ex nc AC IIC T3 / T4	492
2.0/2.1	492670	Partie électrique enrobée antidéflagrante "mb", 32 mm	9,0	8,0	entre -40 °C et +50 °C	-	IP65	II 2 G Ex mb II T4	500
2.0/2.1	492070	Partie électrique enrobée antidéflagrante "mb", avec boîtier métallique étanche, 50 mm	8,0	9,0	entre -40 °C et +65 °C	-	IP67	II 2 G Ex mb II T4 / T5	501
2.0/2.1	493640	Partie électrique enrobée résistante aux flammes "db mb", double fréquence	8,0	8,0	entre -40 °C et +75 °C	-	IP65	II 2 G Ex db mb IIC T4	508
2.0/2.1	495905	Partie électrique enrobée résistante aux flammes "db mb", 37 mm	8,0	8,0	entre -40 °C et +65 °C	-	IP67	II 2 G Ex db mb IIC T4	505
2.0/2.1	494040	Partie électrique antidéflagrante à sécurité augmentée "eb", 50 mm	8,0	8,0	entre -40 °C et +90 °C	-	IP67	II 2 G Ex eb IIC T3 / T4	509
2.0/2.1	483371	Partie électrique antidéflagrante à sécurité augmentée "eb", 50 mm	8,0	8,0	entre -40 °C et +65 °C	-	IP67	II 2 G Ex eb IIC T4	509
2.0/2.1	492190	Partie électrique enrobée, antidéflagrante, à sécurité augmentée "eb", 50 mm	9,0	11,0	entre -40 °C et +75 °C	-	IP66	II 2 G Ex eb mb II T3 / T4	512
2.0/2.2	486265	Bobine avec borne à vis, haute température, haute puissance, 40 mm	14,0	14,0	entre -40 °C et +50 °C	-	IP 44 à 67	-	484
2.0/2.2	492425	Bobine pour connecteur à broches DIN, haute température, 32 mm	14,0	14,0	entre -40 °C et +50 °C	-	IP65	-	455
2.0/2.2	481044	Bobine avec borne à vis haute puissance, 40 mm	-	14,0	entre -40 °C et +50 °C	-	IP 44 à 67	-	483
2.0/2.2	495880	Partie électrique antidéflagrante "nc AC", 32 mm	14,0	14,0	entre -40 °C et +50 °C	-	IP65	II 3 G Ex nc AC IIC T3	495
2.0/2.2	496155	Partie électrique antidéflagrante à sécurité augmentée "nc AC", 50 mm	14,0	14,0	entre -40 °C et +65 °C	-	IP67	II 3 G Ex nc AC IIC T3	497
2.0/2.1	HZ10	Partie électrique enrobée antidéflagrante "mb", double fréquence	8,0	8,0	entre -40 °C et +50 °C	-	IP65	II 2 G Ex mb II T4 / T5	502
2.0/2.2	HZ11	Partie électrique enrobée antidéflagrante "mb", double fréquence	14,0	14,0	entre -40 °C et +50 °C	-	IP65	II 2 G Ex mb II T4 / T5	503
2.2	483816	Bobine pour connecteur à broches DIN pour valves de jetting, 32 mm	14,0	14,0	entre -40 °C et +50 °C	-	IP65	-	460
3.0	482730	Bobine pour connecteur à broches DIN, puissance réduite, 32 mm	7,0	6,0	entre -40 °C et +50 °C	-	IP65	-	456
4.0	485400	Bobine avec borne à vis, bistable, pour les applications par impulsion, 40 mm	13,0	-	entre -40 °C et +50 °C	-	IP44	-	487
4.0	484990	Bobine avec borne à vis, bistable, pour les applications par impulsion, 40 mm	-	11,0	entre -40 °C et +50 °C	-	IP44	-	487
4.0	495915	Partie électrique antidéflagrante à sécurité augmentée "nc AC", 50 mm	13,0	11,0	entre -40 °C et +65 °C	-	IP67	II 3 G Ex nc AC IIC T3	496

INDEX PAR GROUPE ÉLECTRIQUE

Groupe Électrique	Référence de bobine	Désignation	Puissance CC Pn (W)	Puissance CA Pn (W)	Température ambiante	UL	Indice de protection	Protection ATEX ou NEMA 4X (Gaz)	Page
6.0	482740	Bobine pour connecteur à broches DIN, faible puissance, 32 mm	1,6	-	entre -40 °C et +50 °C	-	IP65	-	457
6.0	496125	Partie électrique antidéflagrante "nc AC", faible puissance, 32 mm	1,6	-	entre -40 °C et +50 °C	-	IP65	II 3 G Ex nc IIC T5 / T6	490
6.0	495900	Partie électrique enrobée, résistante aux flammes "db mb", faible puissance, 37 mm	2,0	2,5	entre -40 °C et +65 °C	-	IP67	II 2 G Ex db mb IIC T4 / T5 / T6	504
7.0	483580.01	Partie électrique antidéflagrante à sécurité intrinsèque "ia", 32 mm	3,0	-	entre -40 °C et +55 °C	-	IP65	II 1 G Ex ia IIC T6	513
7.0	488660.01	Partie électrique antidéflagrante à sécurité intrinsèque "ia", 50 mm	3,0	-	entre -40 °C et +65 °C	-	IP67	II 1 G Ex ia IIC T6	519
7.0	488650.01	Partie électrique antidéflagrante à sécurité intrinsèque "ia", 50 mm	0,3 à 3,0	-	entre -40 °C et +65 °C	-	IP66	II 1 G Ex ia IIC T6	518
7.0	488670.01	Partie électrique antidéflagrante à sécurité intrinsèque "ia", 50 mm	0,3 à 3,0	-	entre -40 °C et +65 °C	-	IP65	II 1 G Ex ia IIC T6	520
7.0	490885	Partie électrique antidéflagrante à sécurité intrinsèque "NEMA", 50 mm	3,0	-	entre -40 °C et +60 °C	-	NEMA 4 - 4X	Cl. I, Div. I, Gr. A, B, C, D	518
7.0	490890	Partie électrique antidéflagrante à sécurité intrinsèque "NEMA", 50 mm	3,0	-	entre -40 °C et +60 °C	-	NEMA 4 - 4X	Cl. I, Div. I, Gr. A, B, C, D	519
8.0	495910	Partie électrique antidéflagrante à sécurité intrinsèque "ia", "Booster", 37 mm	0,3 à 1,2	-	entre -40 °C et +80 °C	-	IP67	II 1 G Ex ia IIC T6 / T5 / T4	514
9.0	492210	Partie électrique enrobée, antidéflagrante, à sécurité augmentée "eb", "Booster", 50 mm	1,0 à 1,8	-	entre -40 °C et +75 °C	-	IP66	II 2 G Ex eb mb II T5 / T6	511
9.0	496565	Partie électrique antidéflagrante à sécurité intrinsèque "ia", "Booster", 37 mm	0,77 à 2,58	-	entre -40 °C et +80 °C	-	IP67	II 1 G Ex ia IIC T6 / T5 / T4	515
9.0	492965.01	Partie électrique antidéflagrante à sécurité intrinsèque "ia", "Booster", 50 mm	0,3 à 2,3	-	entre -40 °C et +65 °C	-	IP66	II 1 G Ex ia IIC T6	516
10.1	496895	Bobine pour connecteur à broches DIN pour la pétrochimie 37 mm	8,0	8,0	entre -40 °C et +50 °C	-	IP65	-	476
10.1	496560	Partie électrique enrobée résistante aux flammes "db mb", 37 mm	8,0	8,0	entre -40 °C et +65 °C	-	IP67	II 2 G Ex db mb IIC T4	506
10.1	496800	Partie électrique enrobée résistante aux flammes "db mb", 37 mm	8,0	8,0	entre -40 °C et +65 °C	-	IP67	II 2 G Ex db mb IIC T4	507
10.1	492310	Partie électrique enrobée, antidéflagrante, à sécurité augmentée "eb", 50 mm	6,0	6,0	entre -40 °C et +75 °C	-	IP66	II 2 G Ex eb mb II T4 / T5	510
10.2	496555	Partie électrique enrobée résistante aux flammes "db mb", 37 mm	6,0	6,0	entre -40 °C et +65 °C	-	IP67	II 2 G Ex db mb IIC T4 / T5 / T6	506
10.2	496700	Partie électrique enrobée résistante aux flammes "db mb", 37 mm	6,0	6,0	entre -40 °C et +65 °C	-	IP67	II 2 G Ex db mb IIC T4 / T5 / T6	507
11.0	483270	Partie électrique résistante aux flammes "db", 50 mm	8,0	8,0	entre -40 °C et +80 °C	-	IP66	II 2 G Ex db IIC T4 / T5 / T6	498
12.0	482870.01	Partie électrique antidéflagrante à sécurité intrinsèque "ia", 50 mm	3,0	-	entre -40 °C et +65 °C	-	IP66	II 1 G Ex ia IIC T6	517
12.0	492335	Partie électrique antidéflagrante à sécurité intrinsèque "NEMA", 50 mm	3,0	-	entre -40 °C et +60 °C	-	NEMA 4 - 4X	Cl. I, Div. I, Gr. A, B, C, D	517
13.0	495294	Bobine avec connecteur ISO-DIN, 12-24 V CC pour les applications dans le domaine du transport, 32 mm	9,0	-	entre -40 °C et +120 °C	-	IP69K	-	488
13.0	496193	Bobine avec connecteur ISO-DIN, 12-24 V CC pour les applications dans le domaine du transport, 32 mm	9,0	-	entre -40 °C et +120 °C	-	IP69K	-	488
14.1	483824	Bobine avec borne à vis, haute température, haute puissance, 40 mm	19,0	19,0	entre -40 °C et +50 °C	-	IP 44 à 67	-	485
14.1	483541	Bobine avec borne à vis, haute température, haute puissance, 40 mm	20,0	20,0	entre -40 °C et +50 °C	-	IP 44 à 67	-	485
14.2	483764	Bobine pour connecteur à broches DIN, 32 mm, UL	-	9,0	entre -40 °C et +50 °C	●	IP65	-	459
20.0	ZB12	Bobine pour connecteur à broches DIN	12,0	-	entre -10 °C et +50 °C	-	IP65	-	468
20.0	ZB09	Bobine pour connecteur à broches DIN, UL pour CA	-	9,0	entre -10 °C et +50 °C	●	IP65	-	468
20.1	YB12	Bobine avec câbles volants, IP 67	12,0	-	entre -10 °C et +50 °C	-	IP67	-	477
20.1	YB09	Bobine avec câbles volants, IP 67, UL pour CA	-	9,0	entre -10 °C et +50 °C	●	IP67	-	477
20.2	ZB16	Bobine pour connecteur à broches DIN, haute puissance, haute température	16,0	-	entre -10 °C et +50 °C	-	IP65	-	469
20.2	ZH16	Bobine pour connecteur à broches DIN, haute puissance, haute température	16,0	-	entre -10 °C et +80 °C	-	IP65	-	469
20.2	ZB14	Bobine pour connecteur à broches DIN, haute puissance, haute température	-	14,0	entre -10 °C et +50 °C	-	IP65	-	469
20.2	ZH14	Bobine pour connecteur à broches DIN, haute puissance, haute température	-	14,0	entre -10 °C et +80 °C	-	IP65	-	469
21.0	JB14	Bobine pour connecteur à broches DIN	16,0	-	entre -10 °C et +50 °C	-	IP65	-	470
21.0	JB16	Bobine pour connecteur à broches DIN	-	14,0	entre -10 °C et +50 °C	-	IP65	-	470
22.0	KT10	Bobine pour connecteur à broches DIN	10,0	-	entre -10 °C et +50 °C	-	IP65	-	471
22.0	KH09	Bobine pour connecteur à broches DIN	-	9,0	entre -10 °C et +80 °C	-	IP65	-	471
22.0	KT09	Bobine pour connecteur à broches DIN	-	9,0	entre -10 °C et +50 °C	-	IP65	-	471
23.0	XT09	Bobine pour connecteur à broches DIN	-	9,0	entre -10 °C et +50 °C	-	IP54	-	472
24.0	D5	Bobine pour connecteur à broches DIN, 32 mm	9,0	8,0	entre -40 °C et +50 °C	-	IP65	-	474
24.0	LA	Bobine avec câbles volants, IP 67, 32 mm	9,0	9,0	entre -10 °C et +50 °C	-	IP67	-	478
24.0	D4	Bobine pour connecteur à broches DIN, 32 mm, UL	16,0	13,0	entre -40 °C et +50 °C	●	IP65	-	473
24.0	LB-LC	Bobine avec câbles volants, IP 67, 32 mm, UL	16,0	13,0 à 14,0	entre -10 °C et +50 °C	●	IP67	-	479
24.0	XS03	Bobine pour connecteur à broches DIN, 32 mm	-	9,0	entre -40 °C et +50 °C	-	IP65	-	475

INDEX POUR LES PARTIES ÉLECTRIQUES ANTIDÉFLAGRANTES

Référence de bobine	Groupe Électrique	Désignation	Puissance CC Pn (W)	Puissance CA Pn (W)	Température ambiante	UL	Indice de protection	Protection ATEX ou NEMA 4X (Gaz)	Page
496637	1.2	Partie électrique antidéflagrante "nc AC", 22 mm, double fréquence	3,0	3,0	entre -40 °C et +50 °C	-	IP65	II 3 D Ex tc IIC T 95°C	491
495880	2.0/2.2	Partie électrique antidéflagrante "nc AC", 32 mm	14,0	14,0	entre -40 °C et +50 °C	-	IP65	II 3 G Ex nc AC IIC T3	495
496155	2.0/2.2	Partie électrique antidéflagrante à sécurité augmentée "nc AC", 50 mm	14,0	14,0	entre -40 °C et +65 °C	-	IP67	II 3 G Ex nc AC IIC T3	497
495915	4.0	Partie électrique antidéflagrante à sécurité augmentée "nc AC", 50 mm	13,0	11,0	entre -40 °C et +65 °C	-	IP67	II 3 G Ex nc AC IIC T3	496
495870	2.0/2.1	Partie électrique antidéflagrante "nc AC", 32 mm	9,0	8,0	entre -40 °C et +50 °C	-	IP65	II 3 G Ex nc AC IIC T3 / T4	492
495875	2.0/2.1	Partie électrique antidéflagrante "nc AC", 32 mm	7,0	6,0	entre -40 °C et +50 °C	-	IP65	II 3 G Ex nc AC IIC T3 / T4	494
496110	2.0/2.1	Partie électrique antidéflagrante "nc AC", 32 mm	-	9,0	entre -40 °C et +50 °C	-	IP65	II 3 G Ex nc AC IIC T3 / T4	492
495865	1.1	Partie électrique antidéflagrante "nc AC", faible puissance, 22 mm	2,5	2,0	entre -40 °C et +50 °C	-	IP65	II 3 G Ex nc AC IIC T5	490
496125	6.0	Partie électrique antidéflagrante "nc AC", faible puissance, 32 mm	1,6	-	entre -40 °C et +50 °C	-	IP65	II 3 G Ex nc AC IIC T5 / T6	493
492670	2.0/2.1	Partie électrique enrobée antidéflagrante "mb", 32 mm	9,0	8,0	entre -40 °C et +50 °C	-	IP65	II 2 G Ex mb II T4	500
482605	1.1	Partie électrique enrobée antidéflagrante "mb", 32 mm	5,0	4,0	entre -40 °C et +65 °C	-	IP65	II 2 G Ex mb II T4 / T5	498
482606	1.1	Partie électrique enrobée antidéflagrante "mb", faible puissance, 32 mm	2,5	2,0	entre -40 °C et +65 °C	-	IP65	II 2 G Ex mb II T4 / T5	498
492070	2.0/2.1	Partie électrique enrobée antidéflagrante "mb", avec boîtier métallique étanche, 50 mm	8,0	9,0	entre -40 °C et +65 °C	-	IP67	II 2 G Ex mb II T4 / T5	501
HZ10	2.0/2.1	Partie électrique enrobée antidéflagrante "mb", double fréquence	8,0	8,0	entre -40 °C et +50 °C	-	IP65	II 2 G Ex mb II T4 / T5	502
HZ11	2.0/2.2	Partie électrique enrobée antidéflagrante "mb", double fréquence	14,0	14	entre -40 °C et +50 °C	-	IP65	II 2 G Ex mb II T4 / T5	503
483270	11.0	Partie électrique résistante aux flammes "db", 50 mm	8,0	8,0	entre -40 °C et +80 °C	-	IP66	II 2 G Ex db IIC T4 / T5 / T6	498
493640	2.0/2.1	Partie électrique enrobée résistante aux flammes "db mb", double fréquence	8,0	8,0	entre -40 °C et +75 °C	-	IP65	II 2 G Ex db mb IIC T4 / T5	508
495905	2.0/2.1	Partie électrique enrobée résistante aux flammes "db mb", 37 mm	8,0	8,0	entre -40 °C et +65 °C	-	IP67	II 2 G Ex db mb IIC T4	505
496560	10.1	Partie électrique enrobée résistante aux flammes "db mb", 37 mm	8,0	8,0	entre -40 °C et +65 °C	-	IP67	II 2 G Ex db mb IIC T4	506
496800	10.1	Partie électrique enrobée résistante aux flammes "db mb", 37 mm	8,0	8,0	entre -40 °C et +65 °C	-	IP67	II 2 G Ex db mb IIC T4	507
495900	6.0	Partie électrique enrobée, résistante aux flammes "db mb", faible puissance, 37 mm	2,0	2,5	entre -40 °C et +65 °C	-	IP67	II 2 G Ex db mb IIC T4 / T5 / T6	504
496555	10.2	Partie électrique enrobée résistante aux flammes "db mb", 37 mm	6,0	6,0	entre -40 °C et +65 °C	-	IP67	II 2 G Ex db mb IIC T4 / T5 / T6	506
496700	10.2	Partie électrique enrobée résistante aux flammes "db mb", 37 mm	6,0	6,0	entre -40 °C et +65 °C	-	IP67	II 2 G Ex db mb IIC T4 / T5 / T6	507
494040	2.0/2.1	Partie électrique antidéflagrante à sécurité augmentée "eb", 50 mm	8,0	8,0	entre -40 °C et +90 °C	-	IP67	II 2 G Ex eb IIC T3 / T4	509
483371	2.0/2.1	Partie électrique antidéflagrante à sécurité augmentée "eb", 50 mm	8,0	8,0	entre -40 °C et +65 °C	-	IP67	II 2 G Ex eb IIC T4	509
492190	2.0/2.1	Partie électrique enrobée, antidéflagrante, à sécurité augmentée "eb", 50 mm	9,0	11,0	entre -40 °C et +75 °C	-	IP66	II 2 G Ex eb mb II T3 / T4	512
492310	10.1	Partie électrique enrobée, antidéflagrante, à sécurité augmentée "eb", 50 mm	6,0	6,0	entre -40 °C et +75 °C	-	IP66	II 2 G Ex eb mb II T4 / T5	510
492210	9.0	Partie électrique enrobée, antidéflagrante, à sécurité augmentée "eb", "Booster", 50 mm	1,0 à 1,8	-	entre -40 °C et +75 °C	-	IP66	II 2 G Ex eb mb II T5 / T6	511
495910	8.0	Partie électrique antidéflagrante à sécurité intrinsèque "ia", "Booster", 37 mm	0,3 à 1,2	-	entre -40 °C et +80 °C	-	IP67	II 1 G Ex ia IIC T6 / T5 / T4	514
496565	9.0	Partie électrique antidéflagrante à sécurité intrinsèque "ia", "Booster", 37 mm	0,77 à 2,58	-	entre -40 °C et +80 °C	-	IP67	II 1 G Ex ia IIC T6 / T5 / T4	515
483580.01	7.0	Partie électrique antidéflagrante à sécurité intrinsèque "ia", 32 mm	3,0	-	entre -40 °C et +55 °C	-	IP65	II 1 G Ex ia IIC T6	513
488650.01	7.0	Partie électrique antidéflagrante à sécurité intrinsèque "ia", 50 mm	0,3 à 3,0	-	entre -40 °C et +65 °C	-	IP66	II 1 G Ex ia IIC T6	518
488660.01	7.0	Partie électrique antidéflagrante à sécurité intrinsèque "ia", 50 mm	3,0	-	entre -40 °C et +65 °C	-	IP67	II 1 G Ex ia IIC T6	519
488670.01	7.0	Partie électrique antidéflagrante à sécurité intrinsèque "ia", 50 mm	0,3 à 3	-	entre -40 °C et +65 °C	-	IP65	II 1 G Ex ia IIC T6	520
492965.01	9.0	Partie électrique antidéflagrante à sécurité intrinsèque "ia", "Booster", 50 mm	0,3 à 2,3	-	entre -40 °C et +65 °C	-	IP66	II 1 G Ex ia IIC T6	516
482870.01	12.0	Partie électrique antidéflagrante à sécurité intrinsèque "ia", 50 mm	3,0	-	entre -40 °C et +65 °C	-	IP66	II 1 G Ex ia IIC T6	517
490885	7.0	Partie électrique antidéflagrante à sécurité intrinsèque "NEMA", 50 mm	3,0	-	entre -40 °C et +60 °C	-	NEMA 4 - 4X	Cl. I, Div. I, Gr. A, B, C, D	518
490890	7.0	Partie électrique antidéflagrante à sécurité intrinsèque "NEMA", 50 mm	3,0	-	entre -40 °C et +60 °C	-	NEMA 4 - 4X	Cl. I, Div. I, Gr. A, B, C, D	519
492335	12.0	Partie électrique antidéflagrante à sécurité intrinsèque "NEMA", 50 mm	3,0	-	entre -40 °C et +60 °C	-	NEMA 4 - 4X	Cl. I, Div. I, Gr. A, B, C, D	517

LISTE DES GROUPES ÉLECTRIQUES

Les bobines et les parties électriques Parker sont classées par groupes déterminant leur compatibilité avec les électrovannes Parker.

Groupe	À utiliser avec
1.1	Vannes standard ou sur la série 2000 avec pilote standard
1.2	Vannes standard ou sur la série 2000 pour un haut débit
1.3	Vannes standard ou sur la série 2000 de la bobine W
2.0	Vannes standard ou sur la série 7000 avec pilote standard
2.1	Vannes standard ou sur la série 7000, pour bobines 8 - 9 W
2.2	Vannes standard ou sur la série 7000, pour bobines 14 W
3.0	Vannes standard ou sur la série 7000 avec une puissance réduite
4.0	Vannes standard ou sur la série 7000, pour des bobines bistables (impulsions) ou des parties électriques
6.0	Vannes spéciales "97" ou sur la série 7000, pour des bobines à sécurité intrinsèque ou des parties électriques
7.0	Vannes spéciales "90", pour des bobines à sécurité intrinsèque ou des parties électriques
8.0	Vannes spéciales "97" ou sur la série 7000, pour des bobines à sécurité intrinsèque ou des parties électriques avec Booster
9.0	Vannes spéciales "xx" ou sur la série 9000, pour des bobines à sécurité intrinsèque ou des parties électriques avec Booster
10.1	Vannes standard ou sur la série 9000 avec pilote standard
10.2	Vannes standard ou sur la série 9000 "db mb"
11.0	Vannes standard ou sur la série 9000 "1D"
12.0	Vannes standard ou sur la série 9000 avec réactivation manuelle
13.0	Vannes spéciales ou sur la série 7000 pour le transport
14.1	Vannes spéciales ou sur la série 7000 pour les brûleurs à mazout
14.2	Vannes spéciales ou sur la série 7000 pour les brûleurs à mazout
20.1	Vannes standard ou sur la série 7000, pour bobine Z-Y
20.2	Vannes standard ou sur la série 7000, pour bobine Z-Y "haute puissance"
21.0	Vannes standard ou sur la série 7000, pour bobine J-B
22.0	Vannes standard pour bobine KP-KT-KH
23.0	Vannes standard pour bobine XP-XT pour les brûleurs à mazout
24.0	Vannes standard pour les bobines Liquipure® pour les distributeurs de boissons

SOMMAIRE

INTRODUCTION

Index par référence de bobine.....	446
Index par groupe électrique.....	448
Index pour les parties électriques antidéflagrantes.....	450
Liste des groupes électrique.....	451

BOBINES

Bobines pour connecteur à broches DIN.....	454
Bobines avec câbles volants.....	477
Bobines avec bornes à vis.....	482
Bobines avec connecteur ISO-DIN.....	488

PARTIES ÉLECTRIQUES ANTIDÉFLAGRANTES

Niveau de protection "nc AC".....	490
Niveau de protection "db".....	498
Niveau de protection "mb".....	499
Niveau de protection "db mb".....	504
Niveau de protection "eb".....	509
Niveau de protection "ia".....	513

BOÎTIERS.....	522
---------------	-----

ACCESSOIRES DE BOBINE.....	526
----------------------------	-----

ENVIRONNEMENTS EXPLOSIFS.....	528
-------------------------------	-----

ANNEXES POUR BOBINES

Tableau informatif pour les barrières IS.....	538
Tableau des codes tension pour les bobines et les parties électriques.....	540



BOBINES 32 mm

Ces bobines peuvent être montées avec toutes les électrovannes Parker correspondant au groupe électrique spécifique.

Voir la colonne "Groupe électrique" sur les pages concernant les vannes.

Ensemble enrobé comprenant une bobine, un circuit magnétique et une broche enfichable.

Le matériau synthétique enrobé permet de protéger l'ensemble compact contre la pénétration de corps étrangers (ex. : poussières, huile, eau, etc).

Montage facile dans les espaces confinés - Protection contre les chocs et la corrosion -

Simplification du passage aux nouvelles exigences de l'équipement existant, etc.

Les bobines sont conformes aux normes de sécurité CEI/CENELEC ainsi qu'à la directive européenne Basse tension.



Caractéristiques		Standard			Double fréquence		
Réf. (sans broche DIN)		481865			483510		
Réf. (avec broche DIN)		482725			482635		
Groupe électrique		2.0/2.1					
Indice de protection		IP65 selon les normes CEI/EN 60529 (avec broche DIN).					
Classe d'isolation		F 155 °C					
Raccordement électrique		La bobine est raccordée à l'aide d'une broche 2 P + T selon EN 175301-803, type A.					
Température ambiante		entre -40 °C et +50 °C L'application est également limitée par la plage de température de la vanne.					
Alimentation électrique	CC	Pn (chaud)	9 W		-		
		P (froid) 20 °C	12 W		-		
	CA	Pn (maintien)	8 W		9 W		
		Attraction (froid)	26 VA (9 W)		32 VA (10 W)		
Poids		130 g (sans broche)					
Tensions "Un"		V CA/Hz	Code	V CC	Code	V CA/Hz	Code
entre -10 % et +10 % de Un		24/50	A2	24	C2	24/50, 24/60	P0
		48/50	A4	48	C4	48/50, 48/60	S4
		110/50	A5	110	C5	110-115/50, 120/60	S5
		220-230/50	3D			220-240/50, 240/60	S6

Pour commander une bobine, choisissez la réf. bobine + le code tension, par exemple : 481865 pour 24 V CC = 481865C2

D'autres tensions possibles se trouvent dans le tableau des codes tension à la fin de la section des bobines.

Ces bobines doivent être utilisées avec les boîtiers adaptés. Voir les exemples ci-dessous :

Le kit d'assemblage de la bobine avec la réf. 2995 correspond au "boîtier" du système de numérotation des vannes Lucifer® (vanne - boîtier - bobine - tension).

Il est composé d'une plaque signalétique avec des informations concernant le type de vanne, d'une rondelle et d'un écrou pour assurer la fixation entre la bobine de 32 mm et la vanne.

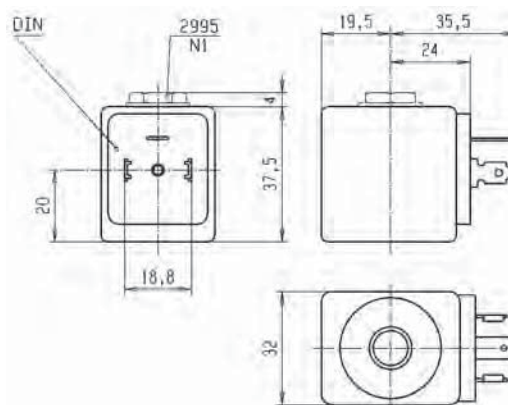

BOBINES HAUTE TEMPÉRATURE 32 MM

Ces bobines peuvent être montées avec toutes les électrovannes Parker correspondant au groupe électrique spécifique.

Voir la colonne "Groupe électrique" sur les pages concernant les vannes.

Ensemble enrobé comprenant une bobine, un circuit magnétique et une broche enfichable.

Le matériau synthétique enrobé permet de protéger l'ensemble compact contre la pénétration de corps étrangers (ex. : poussières, huile, eau, etc).

Montage facile dans les espaces confinés - Protection contre les chocs et la corrosion - Simplification du passage aux nouvelles exigences de l'équipement existant, etc.

Les bobines sont conformes aux normes de sécurité CEI/CENELEC ainsi qu'à la directive européenne Basse tension.



Caractéristiques		Haute température				Haute température et haute puissance				
Réf. (sans broche DIN)		492453				492425				
Réf. (avec broche DIN)		492726				492727				
Groupe électrique		2.0/2.1				2.0/2.2				
Indice de protection		IP65 selon les normes CEI/EN 60529 (avec broche DIN).								
Classe d'isolation		H 180 °C								
Raccordement électrique		La bobine est raccordée à l'aide d'une broche 2 P + T selon EN 175301-803, type A.								
Température ambiante		entre -40 °C et +50 °C L'application est également limitée par la plage de température de la vanne.								
Alimentation électrique	CC	Pn (chaud)	9 W				14 W			
		P (froid) 20 °C	12 W				21 W			
	CA	Pn (maintien)	8 W				14 W			
		Attraction (froid)	26 VA (9 W)				55 VA (18 W)			
Poids		130 g (sans broche)								
Tensions "Un"		V CA/Hz	Code	V CC	Code	V CA/Hz	Code	V CC	Code	
entre -10 % et +10 % de Un		24/50	A2	24	C2	24/50	A2	24	C2	
		48/50	A4			110/50	A5			
		110/50	A5			230/50	F4			
		220/50-230/50	3D							

Pour commander une bobine, choisissez la réf. bobine + le code tension, par exemple : 492453 pour 24 V CC = 492453C2
D'autres tensions possibles se trouvent dans le tableau des codes tension à la fin de la section des bobines.

Ces bobines doivent être utilisées avec les boîtiers adaptés. Voir les exemples ci-dessous :

Le kit d'assemblage de la bobine avec la réf. 2995 correspond au "boîtier" du système de numérotation des vannes Lucifer® (vanne - boîtier - bobine - tension).

Il est composé d'une plaque signalétique avec des informations concernant le type de vanne, d'une rondelle et d'un écrou pour assurer la fixation entre la bobine de 32 mm et la vanne.

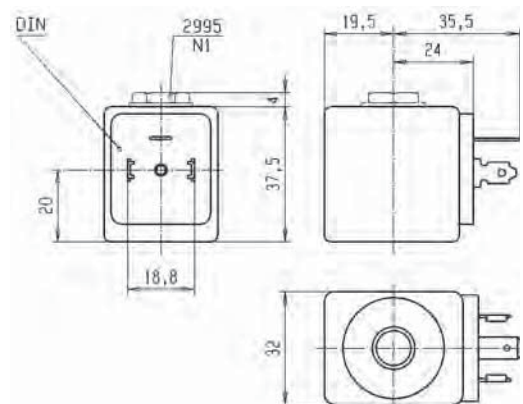

BOBINES À PUISSANCE RÉDUITE 32 mm

Ces bobines peuvent être montées avec toutes les électrovannes Parker correspondant au groupe électrique spécifique.

Voir la colonne "Groupe électrique" sur les pages concernant les vannes.

Ensemble enrobé comprenant une bobine, un circuit magnétique et une broche enfichable.

Le matériau synthétique enrobé permet de protéger l'ensemble compact contre la pénétration de corps étrangers (ex. : poussières, huile, eau, etc).

Montage facile dans les espaces confinés - Protection contre les chocs et la corrosion - Simplification du passage aux nouvelles exigences de l'équipement existant, etc.

Les bobines sont conformes aux normes de sécurité CEI/CENELEC ainsi qu'à la directive européenne Basse tension.



Caractéristiques		Puissance réduite			
Réf. (sans broche DIN)		482730			
Réf. (avec broche DIN)		482735			
Groupe électrique		3.0			
Indice de protection		IP65 selon les normes CEI/EN 60529 (avec broche DIN).			
Classe d'isolation		F 155 °C			
Raccordement électrique		La bobine est raccordée à l'aide d'une broche 2 P + T selon EN 175301-803, type A.			
Température ambiante		entre -40 °C et +50 °C L'application est également limitée par la plage de température de la vanne.			
Alimentation électrique	CC	Pn (chaud)	7 W		
		P (froid) 20 °C	9 W		
	CA	Pn (maintien)	6 W		
		Attraction (froid)	20 VA (7 W)		
Poids		130 g (sans broche)			
Tensions "Un"		V CA/Hz	Code	V CC	Code
entre -10 % et +10 % de Un		48/50	A4	24	C2
		110/50-115/50	A7	48	C4
		220-230/50	3D		

Pour commander une bobine, choisissez la réf. bobine + le code tension, par exemple : 482730 pour 24 V CC = 482730C2
D'autres tensions possibles se trouvent dans le tableau des codes tension à la fin de la section des bobines.

Ces bobines doivent être utilisées avec les boîtiers adaptés. Voir les exemples ci-dessous :

Le kit d'assemblage de la bobine avec la réf. 2995 correspond au "boîtier" du système de numérotation des vannes Lucifer® (vanne - boîtier - bobine - tension).

Il est composé d'une plaque signalétique avec des informations concernant le type de vanne, d'une rondelle et d'un écrou pour assurer la fixation entre la bobine de 32 mm et la vanne.

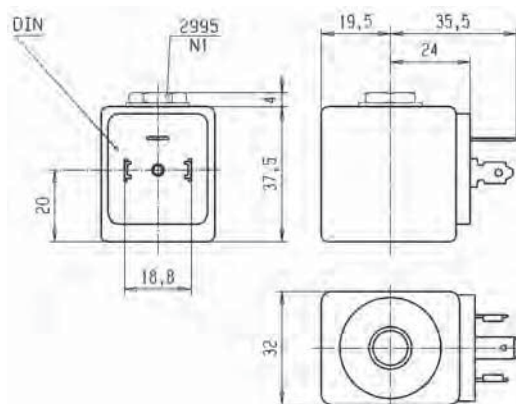

BOBINES À FAIBLE PUISSANCE 32 mm

Ces bobines peuvent être montées avec toutes les électrovannes Parker correspondant au groupe électrique spécifique.

Voir la colonne "Groupe électrique" sur les pages concernant les vannes.

Ensemble enrobé comprenant une bobine, un circuit magnétique et une broche enfichable.

Le matériau synthétique enrobé permet de protéger l'ensemble compact contre la pénétration de corps étrangers (ex. : poussières, huile, eau, etc).

Montage facile dans les espaces confinés - Protection contre les chocs et la corrosion - Simplification du passage aux nouvelles exigences de l'équipement existant, etc.

Les bobines sont conformes aux normes de sécurité CEI/CENELEC ainsi qu'à la directive européenne Basse tension.



Caractéristiques		Miniwatt	
Référence (sans broche DIN)		482740	
Référence (avec broche DIN)		482745	
Groupe électrique		6.0	
Indice de protection		IP65 selon les normes CEI/EN 60529 (avec broche DIN).	
Classe d'isolation		F 155 °C	
Raccordement électrique		La bobine est raccordée à l'aide d'une broche 2 P + T selon EN 175301-803, type A.	
Température ambiante		entre -40 °C et +50 °C L'application est également limitée par la plage de température de la vanne.	
Alimentation électrique	CC	Pn (chaud)	1,6 W
		P (froid) 20 °C	2,1 W
	CA	Pn (maintien)	-
		Attraction (froid)	-
Poids		130 g (sans broche)	
Tensions "Un"		V CC	Code
entre -10 % et +10 % de Un		24	C2
		48	C4
		110	C5

Pour commander une bobine, choisissez la réf. bobine + le code tension, par exemple : 482740 pour 24 V CC = 482740C2
D'autres tensions possibles se trouvent dans le tableau des codes tension à la fin de la section des bobines.

Ces bobines doivent être utilisées avec les boîtiers adaptés. Voir les exemples ci-dessous :

Le kit d'assemblage de la bobine avec la réf. 2995 correspond au "boîtier" du système de numérotation des vannes Lucifer® (vanne - boîtier - bobine - tension).

Il est composé d'une plaque signalétique avec des informations concernant le type de vanne, d'une rondelle et d'un écrou pour assurer la fixation entre la bobine de 32 mm et la vanne.

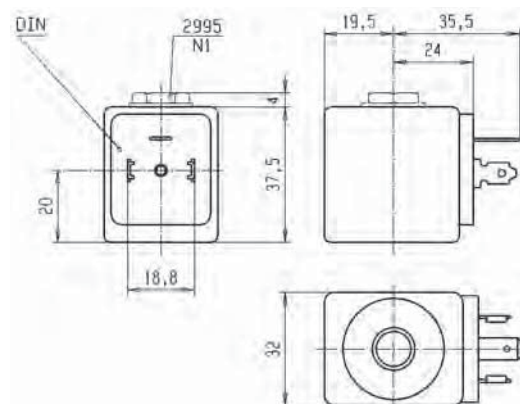



BOBINE UL 32 mm

Cette bobine peut être montée avec toutes les électrovannes Parker correspondant au groupe électrique spécifique.

Voir la colonne "Groupe électrique" sur les pages concernant les vannes.

Ensemble enrobé comprenant une bobine, un circuit magnétique et une broche enfichable.

Le matériau synthétique enrobé permet de protéger l'ensemble compact contre la pénétration de corps étrangers (ex. : poussières, huile, eau, etc).

Montage facile dans les espaces confinés - Protection contre les chocs et la corrosion - Simplification du passage aux nouvelles exigences de l'équipement existant, etc.

Les bobines sont conformes aux normes de sécurité CEI/CENELEC ainsi qu'à la directive européenne Basse tension.



Caractéristiques		Bobine homologuée UL - fichier UL n° E125678 - désignation AMIF			
Référence (sans broche DIN)		491514			
Groupe électrique		2.0/2.1			
Indice de protection		IP65 selon les normes CEI/EN 60529 (avec broche DIN).			
Classe d'isolation		F (155 °C)			
Raccordement électrique		La bobine est raccordée à l'aide d'une broche 2 P + T selon EN 175301-803, type A.			
Température ambiante		entre -40 °C et 50 °C L'application est également limitée par la plage de température de la vanne.			
Alimentation électrique	CC	Pn (chaud)	-	12 W	
		P (froid) 20 °C	-	16 W	
	CA	Pn (maintien)	11 W	-	
		Attraction (froid)	40 VA (13 W)	-	
Poids		130 g (sans broche)			
Tensions "Un"		V CA/Hz	Code	V CC	Code
entre -15 % et +10 % de Un		110/50-120/60	P3	24	C2
		220/50-240/60	Q3		

Pour commander une bobine, choisissez la réf. bobine + le code tension, par exemple : 491514 pour 24 V CC = 491514C2
D'autres tensions possibles se trouvent dans le tableau des codes tension à la fin de la section des bobines.

Ces bobines doivent être utilisées avec les boîtiers adaptés. Voir les exemples ci-dessous :

Le kit d'assemblage de la bobine réf. 2995 sans vanne UL et avec la réf. 2995.03 avec vanne UL correspond au "boîtier" du système de numérotation des vannes Lucifer® (vanne - boîtier - bobine - tension).

Il est composé d'une plaque signalétique avec des informations concernant le type de vanne, d'une rondelle et d'un écrou pour assurer la fixation entre la bobine de 32 mm et la vanne.

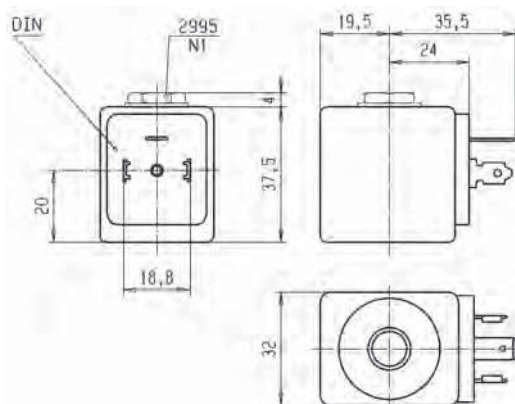

BOBINES POUR
CONNECTEUR
À BROCHES DIN

BOBINE UL 32 mm

Cette bobine peut être montée avec toutes les électrovannes Parker correspondant au groupe électrique spécifique.

Voir la colonne "Groupe électrique" sur les pages concernant les vannes.

Ensemble enrobé comprenant une bobine, un circuit magnétique et une broche enfichable.

Le matériau synthétique enrobé permet de protéger l'ensemble compact contre la pénétration de corps étrangers (ex. : poussières, huile, eau, etc).

Montage facile dans les espaces confinés - Protection contre les chocs et la corrosion - Simplification du passage aux nouvelles exigences de l'équipement existant, etc.

Les bobines sont conformes aux normes de sécurité CEI/CENELEC ainsi qu'à la directive européenne Basse tension.



Caractéristiques		Bobine pour brûleur à mazout - homologuée UL	
Référence (sans broche DIN)		483764	
Groupe électrique		14.2	
Indice de protection		IP65 selon les normes CEI/EN 60529 (avec broche DIN).	
Classe d'isolation		F 155 °C	
Raccordement électrique		Avec broche DIN 43650 A	
Température ambiante		entre -40 °C et 50 °C L'application est également limitée par la plage de température de la vanne.	
Alimentation électrique	CC	Pn (chaud)	-
		P (froid) 20 °C	-
	CA	Pn (maintien)	9 W
		Attraction (froid)	-
Poids		138 g	
Tensions "Un"		V CA/Hz	Code
entre -15 % et +10 % de Un		240/50-60	Q1
		110/50-115/60	Q9
		230/50-240/60	T1

Pour commander une bobine, choisissez la réf. bobine + le code tension, par exemple : 483764 pour 240/50-60 = 483764Q1
D'autres tensions possibles se trouvent dans le tableau des codes tension à la fin de la section des bobines.

Ces bobines doivent être utilisées avec les boîtiers adaptés. Voir les exemples ci-dessous :

Le kit d'assemblage de la bobine avec la réf. 2995 correspond au "boîtier" du système de numérotation des vannes Lucifer® (vanne - boîtier - bobine - tension).

Il est composé d'une plaque signalétique avec des informations concernant le type de vanne, d'une rondelle et d'un écrou pour assurer la fixation entre la bobine de 32 mm et la vanne.

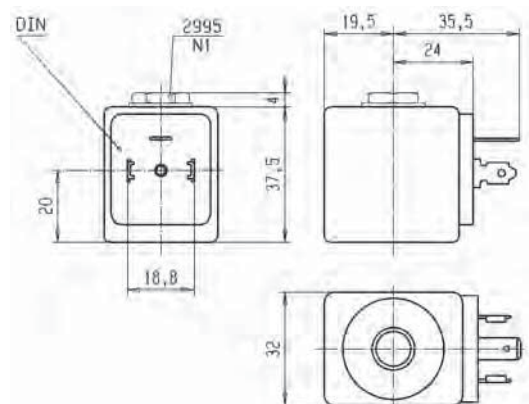

BOBINE 32 mm POUR VALVES A COMMUTATION RAPIDE

Cette bobine peut être montée avec toutes les électrovannes Parker correspondant au groupe électrique spécifique.

Voir la colonne "Groupe électrique" sur les pages concernant les vannes.

Ensemble enrobé comprenant une bobine, un circuit magnétique et une broche enfichable.

Le matériau synthétique enrobé permet de protéger l'ensemble compact contre la pénétration de corps étrangers (ex. : poussières, huile, eau, etc).

Montage facile dans les espaces confinés - Protection contre les chocs et la corrosion - Simplification du passage aux nouvelles exigences de l'équipement existant, etc.

Les bobines sont conformes aux normes de sécurité CEI/CENELEC ainsi qu'à la directive européenne Basse tension.



Caractéristiques		Bobine 32 mm 14 W			
Référence		483816			
Groupe électrique		2.2			
Indice de protection		IP65 selon les normes CEI/EN 60529 (avec broche DIN).			
Classe d'isolation		F 155 °C			
Raccordement électrique		Avec broche DIN 43650 A			
Température ambiante		entre -40 °C et +50 °C L'application est également limitée par la plage de température de la vanne.			
Alimentation électrique	CC	Pn (chaud)	14 W		
		P (froid) 20 °C	-		
	CA	Pn (maintien)	14 W		
		Attraction (froid)	-		
Poids		160 g			
Tensions "Un"		V CA/Hz	Code	V CC	Code
entre -10 % et +10 % de Un		24/50	A2	24 V	C2

Pour commander une bobine, choisissez la réf. bobine + le code tension, par exemple : 483816 pour 24 V CC = 483816C2
D'autres tensions possibles se trouvent dans le tableau des codes tension à la fin de la section des bobines.

Ces bobines doivent être utilisées avec les boîtiers adaptés. Voir les exemples ci-dessous :

Le kit d'assemblage de la bobine avec la réf. 2995 correspond au "boîtier" du système de numérotation des vannes Lucifer® (vanne - boîtier - bobine - tension).

Il est composé d'une plaque signalétique avec des informations concernant le type de vanne, d'une rondelle et d'un écrou pour assurer la fixation entre la bobine de 32 mm et la vanne.

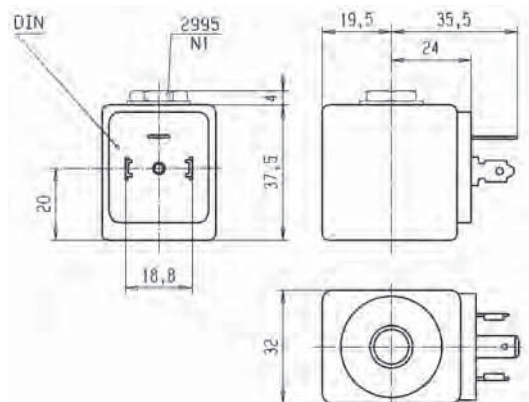

BOBINES 22 mm

Ces bobines peuvent être montées avec toutes les électrovannes Parker correspondant au groupe électrique spécifique.

Voir la colonne "Groupe électrique" sur les pages concernant les vannes.

Cette bobine a été conçue pour les vannes équipées d'un ensemble de tubes miniatures (vannes de la série 2000). Ensemble enrobé comprenant une bobine, un circuit magnétique et une broche enfichable.

Le matériau synthétique enrobé permet de protéger l'ensemble compact contre la pénétration de corps étrangers (ex. : poussières, huile, eau, etc).

Montage facile dans les espaces confinés - Protection contre les chocs et la corrosion - Simplification du passage aux nouvelles exigences de l'équipement existant, etc.

Cette bobine est conforme aux normes de sécurité CEI/CENELEC ainsi qu'à la directive européenne Basse tension.



Caractéristiques		Faible puissance				Haute puissance				
Réf. (sans broche DIN)		488980				481180				
Réf. (avec broche DIN)		481045				481530				
Groupe électrique		1.1								
Indice de protection		IP65 selon les normes CEI/EN 60529 (avec broche DIN).								
Classe d'isolation		F 155 °C								
Raccordement électrique		La bobine est raccordée à l'aide d'une broche 2 P + T selon EN 175301-803, type B.								
Température ambiante		entre -40 °C et +50 °C L'application est également limitée par la plage de température de la vanne.								
Alimentation électrique	CC	Pn (chaud)	2,5 W				5 W			
		P (froid) 20 °C	3 W				6,5 W			
	CA	Pn (maintien)	2 W				4 W			
		Attraction (froid)	5,7 VA (2,5 W)				8,9 VA (5 W)			
Poids		100 g avec broche DIN								
Tensions "Un"		V CA/Hz	Code	V CC	Code	V CA/Hz	Code	V CC	Code	
entre -10 % et +10 % de Un		24/50	A2	24	C2	24/50	A2	24	C2	
		48/50	A4	48	C4	110/50-115/50	0A			
		110/50-115/50	0A	110	C5	220/50-230/50	3D			

Pour commander une bobine, choisissez la réf. bobine + le code tension, par exemple : 488980 pour 24 V CC = 488980C2
D'autres tensions possibles se trouvent dans le tableau des codes tension à la fin de la section des bobines.

Ces bobines doivent être utilisées avec les boîtiers adaptés. Voir les exemples ci-dessous :

Le kit d'assemblage de la bobine avec la réf. 8993 correspond au système de numérotation pour les boîtiers des vannes Lucifer® (vanne - boîtier - bobine - tension).

Il est composé d'une plaque signalétique avec des informations concernant le type de vanne, d'une rondelle et d'un écrou pour fixer la bobine de 22 mm sur la vanne.

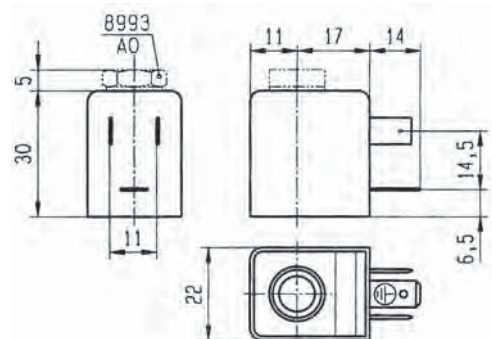



BOBINE UL 22 mm

Ces bobines peuvent être montées avec toutes les électrovannes Parker correspondant au groupe électrique spécifique.

Voir la colonne "Groupe électrique" sur les pages concernant les vannes.

Cette bobine a été conçue pour les vannes équipées d'un ensemble de tubes miniatures (vannes de la série 2000). Ensemble enrobé comprenant une bobine, un circuit magnétique et une broche enfichable.

Le matériau synthétique enrobé permet de protéger l'ensemble compact contre la pénétration de corps étrangers (ex. : poussières, huile, eau, etc).

Montage facile dans les espaces confinés - Protection contre les chocs et la corrosion - Simplification du passage aux nouvelles exigences de l'équipement existant, etc.

Cette bobine est conforme aux normes de sécurité CEI/CENELEC ainsi qu'à la directive européenne Basse tension.



Caractéristiques		UL standard (uniquement en cas d'utilisation avec les vannes 321K, 121M et 131M)			
Référence (sans broche DIN)		492912			
Référence (avec broche DIN)		492919			
Groupe électrique		1.1			
Indice de protection		IP65 selon les normes CEI/EN 60529 (avec broche DIN).			
Classe d'isolation		A 105 °C pour UL/CSA			
Raccordement électrique		La bobine est raccordée à l'aide d'une broche 2 P + T selon EN 175301-803, type B.			
Température ambiante		entre -40 °C et +50 °C L'application est également limitée par la plage de température de la vanne.			
Alimentation électrique	CC	Pn (chaud)	4 W		
		P (froid) 20 °C	4,5 W		
	CA	Pn (maintien)	3 W		
		Attraction (froid)	7,5 VA (4 W)		
Poids		100 g avec broche DIN			
Tensions "Un"		V CA/Hz	Code	V CC	Code
entre -15 % et +10 % de Un		24/50-24/60	P0	24	C2
		48/50-48/60	S4		
		115/50-120/60	P8		
		230/50-240/60	T1		

Pour commander une bobine, choisissez la réf. bobine + le code tension, par exemple : 492912 pour 24 V CC = **492412C2**
D'autres tensions possibles se trouvent dans le tableau des codes tension à la fin de la section des bobines.

Ces bobines doivent être utilisées avec les boîtiers adaptés. Voir les exemples ci-dessous :

Le kit d'assemblage de la bobine avec la réf. **8993** correspond au "boîtier" du système de numérotation des vannes Lucifer® (vanne - boîtier - bobine - tension).

Il est composé d'une plaque signalétique avec des informations concernant le type de vanne, d'une rondelle et d'un écrou pour assurer la fixation entre la bobine de 32 mm et la vanne.

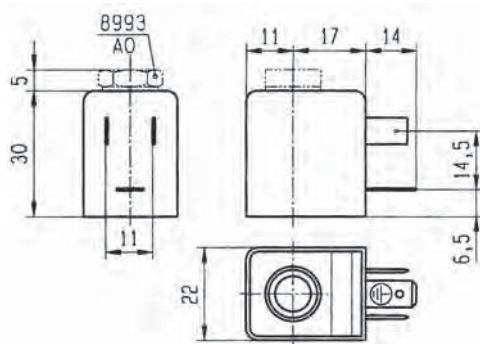

BOBINE À FRÉQUENCE DOUBLE 22 mm

Cette bobine peut être montée avec toutes les électrovannes Parker correspondant au groupe électrique spécifique.

Voir la colonne "Groupe électrique" sur les pages concernant les vannes.

Cette bobine a été conçue pour les vannes équipées d'un ensemble de tubes miniatures (vannes de la série 2000). Ensemble enrobé comprenant une bobine, un circuit magnétique et une broche enfichable.

Le matériau synthétique enrobé permet de protéger l'ensemble compact contre la pénétration de corps étrangers (ex. : poussières, huile, eau, etc).

Montage facile dans les espaces confinés - Protection contre les chocs et la corrosion -

Simplification du passage aux nouvelles exigences de l'équipement existant, etc.

La bobine est conforme aux normes de sécurité CEI/CENELEC ainsi qu'à la directive européenne Basse tension.

Connecteur à broches DIN à commander séparément (voir la section des accessoires de la bobine).



Caractéristiques		Double fréquence	
Référence (sans broche DIN)		483590	
Groupe électrique		1.1	
Indice de protection		IP65 selon les normes CEI/EN 60529 (avec broche DIN).	
Classe d'isolation		F 155 °C	
Raccordement électrique		La bobine est raccordée à l'aide d'une broche 2 P + T selon EN 175301-803, type B.	
Température ambiante		entre -40 °C et +50 °C L'application est également limitée par la plage de température de la vanne.	
Alimentation électrique	CC	Pn (chaud)	-
		P (froid) 20 °C	-
CA		Pn (maintien)	3 W
		Attraction (froid)	7,5 VA (4 W)
Poids		100 g avec broche DIN	
Tensions "Un"		V CA/Hz	Code
entre -10 % et +10 % de Un		24/50, 24/60	P0
		48/50, 48/60	S4
		110-115/50, 120/60	S5
		220-240/50, 240/60	S6

Pour commander une bobine, choisissez la réf. bobine + le code tension, par exemple : 483590 pour 24/50,24/60 = 483590P0
D'autres tensions possibles se trouvent dans le tableau des codes tension à la fin de la section des bobines.

Ces bobines doivent être utilisées avec les boîtiers adaptés. Voir les exemples ci-dessous :

Le kit d'assemblage de la bobine avec la réf. 8993 correspond au "boîtier" du système de numérotation des vannes Lucifer® (vanne - boîtier - bobine - tension).

Il est composé d'une plaque signalétique avec des informations concernant le type de vanne, d'une rondelle et d'un écrou pour assurer la fixation entre la bobine de 32 mm et la vanne.

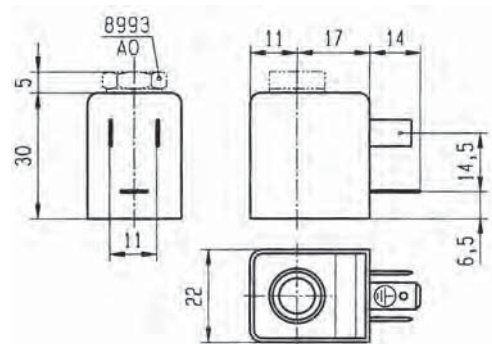

BOBINE À FRÉQUENCE DOUBLE 22 mm

Cette bobine peut être montée avec toutes les électrovannes Parker correspondant au groupe électrique spécifique.

Voir la colonne "Groupe électrique" sur les pages concernant les vannes.

Cette bobine a été conçue pour les vannes équipées d'un ensemble de tubes miniatures (vannes de la série 2000). Ensemble enrobé comprenant une bobine, un circuit magnétique et une broche enfichable.

Le matériau synthétique enrobé permet de protéger l'ensemble compact contre la pénétration de corps étrangers (ex. : poussières, huile, eau, etc).

Montage facile dans les espaces confinés - Protection contre les chocs et la corrosion - Simplification du passage aux nouvelles exigences de l'équipement existant, etc.

La bobine est conforme aux normes de sécurité CEI/CENELEC ainsi qu'à la directive européenne Basse tension.

Connecteur à broches DIN à commander séparément (voir la section des accessoires de la bobine).



Caractéristiques		Double fréquence	
Référence (sans broche DIN)		488143	
Groupe électrique		1.1	
Indice de protection		IP65 selon les normes CEI/EN 60529 (avec broche DIN).	
Classe d'isolation		F 155 °C	
Raccordement électrique		La bobine est raccordée à l'aide d'une broche 2 P + T selon EN 175301-803, type B.	
Température ambiante		entre -40 °C et +50 °C L'application est également limitée par la plage de température de la vanne.	
Alimentation électrique	CC	Pn (chaud)	-
		P (froid) 20 °C	-
CA		Pn (maintien)	2,5 W
		Attraction (froid)	-
Poids		60 g	
Tensions "Un"		V CA/Hz	Code
entre -10 % et +10 % de Un		100/50-60	P1
		200/50-60	P6

Pour commander une bobine, choisissez la réf. bobine + le code tension, par exemple : 488143 pour 100/50-60 = 488143P1
D'autres tensions possibles se trouvent dans le tableau des codes tension à la fin de la section des bobines.

Ces bobines doivent être utilisées avec les boîtiers adaptés. Voir les exemples ci-dessous :

Le kit d'assemblage de la bobine avec la réf. 8993 correspond au "boîtier" du système de numérotation des vannes Lucifer® (vanne - boîtier - bobine - tension).

Il est composé d'une plaque signalétique avec des informations concernant le type de vanne, d'une rondelle et d'un écrou pour assurer la fixation entre la bobine de 32 mm et la vanne.

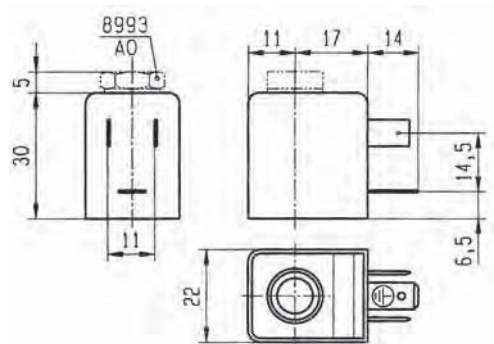

BOBINE À FRÉQUENCE DOUBLE 22 mm

Cette bobine peut être montée avec toutes les électrovannes Parker correspondant au groupe électrique spécifique.

Voir la colonne "Groupe électrique" sur les pages concernant les vannes.

Cette bobine a été conçue pour les vannes équipées d'un ensemble de tubes miniatures (vannes de la série 2000). Ensemble enrobé comprenant une bobine, un circuit magnétique et une broche enfichable.

Le matériau synthétique enrobé permet de protéger l'ensemble compact contre la pénétration de corps étrangers (ex. : poussières, huile, eau, etc).

Montage facile dans les espaces confinés - Protection contre les chocs et la corrosion - Simplification du passage aux nouvelles exigences de l'équipement existant, etc.

La bobine est conforme aux normes de sécurité CEI/CENELEC ainsi qu'à la directive européenne Basse tension.

Connecteur à broches DIN à commander séparément (voir la section des accessoires de la bobine).



Caractéristiques		Double fréquence			
Référence (sans broche DIN)		496131			
Groupe électrique		1.2			
Indice de protection		IP65 selon les normes CEI/EN 60529 (avec broche DIN).			
Classe d'isolation		F 155 °C			
Raccordement électrique		La bobine est raccordée à l'aide d'une broche 2 P + T selon EN 175301-803, type B.			
Température ambiante		entre -40 °C et +50 °C L'application est également limitée par la plage de température de la vanne.			
Alimentation électrique	CC	Pn (chaud)	3 W		
		P (froid) 20 °C	-		
	CA	Pn (maintien)	3 W		
		Attraction (froid)	-		
Poids		60 g			
Tensions "Un"		V CA/Hz	Code	V CC	Code
entre -10 % et +10 % de Un		24/50-60	P0	24 V	C2
		110/50-60	P2	48 V	C4
		230/50-60	P9	110 V	C5
		48/50-60	S4		

Pour commander une bobine, choisissez la réf. bobine + le code tension, par exemple : 496131 pour 24 V CC = 496131C2
D'autres tensions possibles se trouvent dans le tableau des codes tension à la fin de la section des bobines.

"Le kit de boîtier est déjà inclus dans la référence de bobine et il n'est pas nécessaire de le commander séparément."

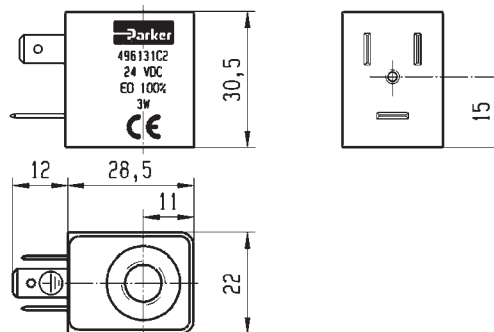

BOBINE À FRÉQUENCE DOUBLE 22 mm

Cette bobine peut être montée avec toutes les électrovannes Parker correspondant au groupe électrique spécifique.

Voir la colonne "Groupe électrique" sur les pages concernant les vannes.

Cette bobine a été conçue pour les vannes équipées d'un ensemble de tubes miniatures (vannes de la série 2000). Ensemble enrobé comprenant une bobine, un circuit magnétique et une broche enfichable.

Le matériau synthétique enrobé permet de protéger l'ensemble compact contre la pénétration de corps étrangers (ex. : poussières, huile, eau, etc).

Montage facile dans les espaces confinés - Protection contre les chocs et la corrosion - Simplification du passage aux nouvelles exigences de l'équipement existant, etc.

La bobine est conforme aux normes de sécurité CEI/CENELEC ainsi qu'à la directive européenne Basse tension.

Connecteur à broches DIN à commander séparément (voir la section des accessoires de la bobine).



Caractéristiques		Double fréquence			
Référence (sans broche DIN)		496482			
Groupe électrique		1.2			
Indice de protection		IP65 selon les normes CEI/EN 60529 (avec broche DIN).			
Classe d'isolation		F 155 °C			
Raccordement électrique		La bobine est raccordée à l'aide d'une broche 2 P + T selon EN 175301-803, type B.			
Température ambiante		entre -40 °C et +50 °C L'application est également limitée par la plage de température de la vanne.			
Alimentation électrique	CC	Pn (chaud)	3 W		
		P (froid) 20 °C	-		
	CA	Pn (maintien)	3 W		
		Attraction (froid)	-		
Poids		75 g			
Tensions "Un"		V CA/Hz	Code	V CC	Code
entre -10 % et +10 % de Un		24/50-60	P0	24 V	C2
		110/50-60	P2	48 V	C4
		230/50-60	P9	110 V	C5
		48/50-60	S4		

Pour commander une bobine, choisissez la réf. bobine + le code tension, par exemple : 496482 pour 24 V CC = 496482C2
D'autres tensions possibles se trouvent dans le tableau des codes tension à la fin de la section des bobines.

"Le kit de boîtier est déjà inclus dans la référence de bobine et il n'est pas nécessaire de le commander séparément."

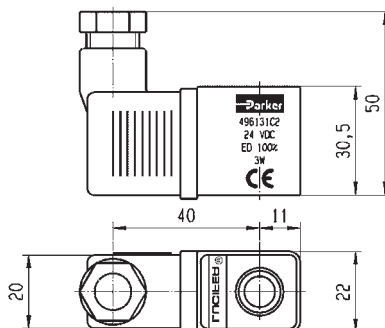

BOBINES POUR
CONNECTEUR
À BROCHES DIN

BOBINE DE LA SÉRIE WB, 22 mm

Ces bobines peuvent être montées avec toutes les électrovannes Parker correspondant au groupe électrique spécifique.

Voir la colonne "Groupe électrique" sur les pages concernant les vannes.

Ces bobines peuvent être montées par la majorité des opérateurs de type 2. Bobine fabriquée avec du fil de cuivre de classe H, moulée dans du polyester à base de matériaux thermoplastiques avec 30 % de fibre de verre. Indice de protection IP65 avec connecteur à 3 broches DIN 43650A et joint adapté.

Le matériau synthétique enrobé permet de protéger l'ensemble compact contre la pénétration de corps étrangers (ex. : poussière, huile, eau, etc). Cette bobine est conforme aux normes de sécurité CEI/CENELEC ainsi qu'à la directive européenne Basse tension.

Pour la version homologuée UL : fichier UL n° MH19410.

Connecteur à broches DIN à commander séparément (voir la section des accessoires de la bobine).



Caractéristiques		Standard	Version homologuée UL	Haute puissance			
Réf. (sans broche DIN)		WB4.5 pour CA WB5.0 pour CC	WB4.5 UR WB5.0 cURus (24 V CC uniquement)	WB8.0			
Groupe électrique		1.3					
Indice de protection		IP65 selon les normes CEI/EN 60529 (avec broche DIN et joint d'étanchéité)					
Classe d'isolation		F 155 °C	F 155 °C	F 155 °C			
Raccordement électrique		La bobine est raccordée à l'aide d'une broche 2 P + T selon EN 175301-803, type B.					
Température ambiante		entre -10 °C et +50 °C		entre -10 °C et +50 °C			
		L'application est également limitée par la plage de température de la vanne.					
Alimen- tation électrique	CC	P (froid) 20 °C	5 W	-	-		
	CA	Pn (maintien)	4,5 W	4,5 W	8 W		
		Attraction (froid)	7,5 VA	7,5 VA	11 VA		
Poids		90 g (sans broche)					
Tensions "Un"		WB4.5 V CA/Hz	Numéro de commande	WB4.5 UR V CA/Hz	Numéro de commande	WB8.0 V CA/Hz	Numéro de commande
entre -10 % et +10 % de Un pour CA entre -5 % et +10 % de Un pour CC		100/50-60	302609	115/60	304087	115/50-60	302672
		115/50-60	304260	208-240/60	304089	230/50-60	302674
		230/50-60	302612	24/60	304086	24/50-60	302670
		110/50	304316				
		WB5.0 V CC	Numéro de commande	WB5.0 cURus V CC	Numéro de commande		
		110 V CC	302660	24 V CC	302654		
		12 V CC	302652				

Pour commander une bobine : utilisez le numéro de commande à 6 chiffres - Exemple de code : WB8.0 pour 115/50-60 = 302672
D'autres tensions possibles se trouvent dans le tableau des codes tension à la fin de la section des bobines.

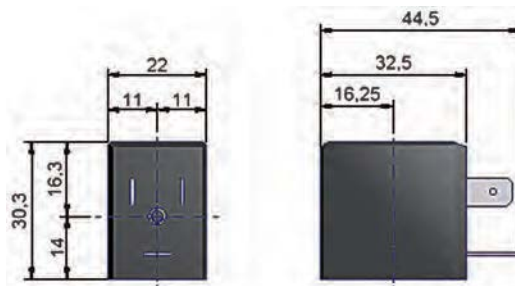



BOBINE DE LA SÉRIE ZB

Ces bobines peuvent être montées avec toutes les électrovannes Parker correspondant au groupe électrique spécifique.

Voir la colonne "Groupe électrique" sur les pages concernant les vannes.

Bobine fabriquée avec du fil de cuivre de classe H, moulée dans du polyester à base de matériaux thermoplastiques avec 30 % de fibre de verre.

Indice de protection IP65 conforme à EN 175301-803:2006-A. Connecteur à 3 broches.

Cette bobine est conforme aux normes de sécurité CEI/CENELEC ainsi qu'à la directive européenne Basse tension.

Pour la version homologuée UL : fichier UL n° MH19410.

Connecteur à broches DIN à commander séparément (voir la section des accessoires de la bobine).



Caractéristiques		Standard			Version homologuée UL		
Référence (sans broche DIN)		ZB09/ZB12			ZB09 pour CA uniquement		
Groupe électrique		20.1					
Indice de protection		IP65 selon les normes CEI/EN 60529 (avec broche DIN et joint d'étanchéité)					
Classe d'isolation		F 155 °C					
Raccordement électrique		La bobine est raccordée à l'aide d'une broche 2 P + T selon EN 175301-803 - A					
Température ambiante		entre -10 °C et +50 °C L'application est également limitée par la plage de température de la vanne.					
Alimen- tation électrique	CC	P (froid) 20 °C				12 W	
	CA	P (froid) 20 °C				9 W	
		Attraction (froid)				25 VA	
Poids		130 g					
Tensions "Un"		V CA/Hz	Número de commande	V CC	Número de commande	V CA/Hz	Número de commande
entre -10 % et +10 % de Un pour CA	ZB09 24/50-60	304004	ZB12 12 CC	304018	ZB09 24/60	304048	
	ZB09 12/50-60	304002	ZB12 24 CC	304020	ZB09 110-120/60	304011	
entre -5 % et +10 % de Un pour CC	ZB09 230/50-60	304012	ZB12 110 CC	304022	ZB09 208-240/60	304051	
	ZB09 115/50-60	304010	ZB12 48 V CC	304021			
	ZB09 100/50-60	304009					
	ZB09 240/50-60	304014					
	ZB09 48/50-60	304008					
	ZB09 110-120/60	304011					
ZB09 380/50-60	304016						

Pour commander une bobine : utilisez le numéro de commande à 6 chiffres - Exemple de code : ZB09 24/50-60 = 304004

D'autres tensions possibles se trouvent dans le tableau des codes tension à la fin de la section des bobines.

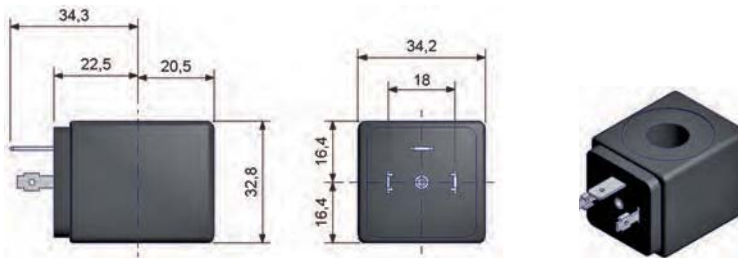



ZB/ZH À HAUTE PUISSANCE - SÉRIE DE BOBINES À HAUTE TEMPÉRATURE

Ces bobines peuvent être montées avec toutes les électrovannes Parker correspondant au groupe électrique spécifique.

Voir la colonne "Groupe électrique" sur les pages concernant les vannes.

Bobine fabriquée avec du fil de cuivre de classe H, moulée dans du polyester à base de matériaux thermoplastiques avec 30 % de fibre de verre.

Indice de protection IP65 conforme à EN 175301-803:2006-A. Connecteur à 3 broches.

Cette bobine est conforme aux normes de sécurité CEI/CENELEC ainsi qu'à la directive européenne Basse tension.

Connecteur à broches DIN à commander séparément (voir la section des accessoires de la bobine).



Caractéristiques		Haute puissance			Haute température et haute puissance				
Réf. (sans broche DIN) Réf. (avec broche DIN)		ZB14/ZB16			ZH14/ZH16				
Groupe électrique		20.2							
Indice de protection		IP65 selon les normes CEI/EN 60529 (avec broche DIN et joint d'étanchéité)							
Classe d'isolation		F 155 °C							
Raccordement électrique		La bobine est raccordée à l'aide d'une broche 2 P + T selon EN 175301-803 - A							
Température ambiante		ZB14/ZB16 entre -10 °C et +50 °C			ZH14/ZH16 entre -10 °C et +80 °C L'application est également limitée par la plage de température de la vanne.				
Alimen- tation électrique	CC	P (froid) 20 °C			16 W				
	CA	P (froid) 20 °C			14 W				
		Attraction (froid)			33 VA				
Poids		130 g (sans broche)							
Tensions "Un"		V CA/Hz	Número de commande	V CC	Número de commande	V CA/Hz	Número de commande	V CC	Número de commande
entre -10 % et +10 % de Un pour CA entre -5 % et +10 % de Un pour CC		ZB14 12/50-60	304052	ZB16 12 CC	304068	ZH14 24/50-60	304100	ZH16 24 CC	304112
		ZB14 24/50-60	304054	ZB16 24 CC	304070	ZH14 115/50-60	304102	ZH16 12 CC	304110
		ZB14 100/50-60	304084	ZB16 110 CC	304072	ZH14 230/50-60	304104		
		ZB14 115/50-60	304060						
		ZB14 230/50-60	304062						
		ZB14 240/50-60	304064						
		ZB14 380/50-60	304066						
		ZB14 48/50-60	304058						

Pour commander une bobine : utilisez le numéro de commande à 6 chiffres - **Exemple de code :** ZH16 pour 24 V CC = 304112
D'autres tensions possibles se trouvent dans le tableau des codes tension à la fin de la section des bobines.

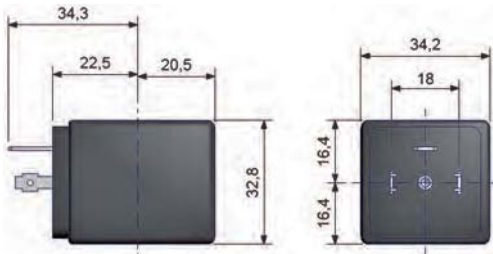

BOBINE DE LA SÉRIE JB

Ces bobines peuvent être montées avec toutes les électrovannes Parker correspondant au groupe électrique spécifique.

Voir la colonne "Groupe électrique" sur les pages concernant les vannes.

Bobine fabriquée avec du fil de cuivre de classe H, moulée dans du polyester à base de matériaux thermoplastiques avec 30 % de fibre de verre.

Indice de protection IP65 conforme à EN 175301-803:2006-A. Connecteur à 3 broches.

Cette bobine est conforme aux normes de sécurité CEI/CENELEC ainsi qu'à la directive européenne Basse tension.

Connecteur à broches DIN à commander séparément (voir la section des accessoires de la bobine).



Caractéristiques		Standard			
Réf. (sans broche DIN)		JB14/JB16			
Groupe électrique		21.0			
Indice de protection		IP65 selon les normes CEI/EN 60529 (avec broche DIN et joint d'étanchéité)			
Classe d'isolation		F 155 °C			
Raccordement électrique		La bobine est raccordée à l'aide d'une broche 2 P + T selon EN 175301-803 - A			
Température ambiante		entre -10 °C et +50 °C L'application est également limitée par la plage de température de la vanne.			
Alimen- tation électrique	CC	P (froid) 20 °C	16 W		
	CA	P (froid) 20 °C	14 W		
		Attraction (froid)	55 VA		
Poids		130 g (sans broche)			
Tensions "Un"		V CA/Hz	Numéro de commande	V CC	Numéro de commande
entre -10 % et +10 % de Un pour CA entre -5 % et +10 % de Un pour CC.		JB14 24/50-60	304900	JB16 12 CC	304945
		JB14 115/50-60	304910	JB16 24 CC	304950
		JB14 230/50-60	304915	JB16 196 CC	304958
		JB14 240/50-60	304920		

Pour commander une bobine : utilisez le numéro de commande à 6 chiffres - **Exemple de code** : JB16 pour 12 V CC = 304945
D'autres tensions possibles se trouvent dans le tableau des codes tension à la fin de la section des bobines.

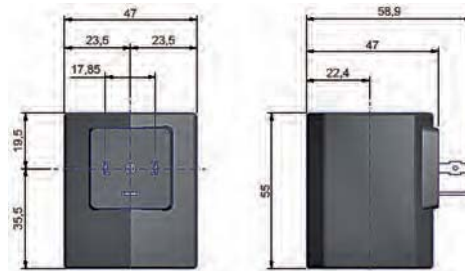



BOBINE DE LA SÉRIE KT/KH

Ces bobines peuvent être montées avec toutes les électrovannes Parker correspondant au groupe électrique spécifique.

Voir la colonne "Groupe électrique" sur les pages concernant les vannes.

Bobine fabriquée avec du fil de cuivre de classe H, moulée dans du polyester à base de matériaux thermoplastiques avec 30 % de fibre de verre.

Indice de protection IP65 conforme à EN 175301-803:2006-A. Connecteur à 3 broches.

Cette bobine est conforme aux normes de sécurité CEI/CENELEC ainsi qu'à la directive européenne Basse tension.

Connecteur à broches DIN à commander séparément (voir la section des accessoires de la bobine).



Caractéristiques		Standard		Haute température			
Réf. (sans broche DIN)		KT09/KT10		KH09			
Groupe électrique		22.0					
Indice de protection		IP65 selon les normes CEI/EN 60529 (avec broche DIN et joint d'étanchéité)					
Classe d'isolation		F 155 °C		180 (H)			
Raccordement électrique		La bobine est raccordée à l'aide d'une broche 2 P + T selon EN 175301-803 - A					
Température ambiante		entre -10 °C et +50 °C		entre -10 °C et +80 °C			
		L'application est également limitée par la plage de température de la vanne.					
Alimen- tation électrique	CC	P (froid) 20 °C	10 W		-		
	CA	P (froid) 20 °C	9 W		9 W		
		Attraction (froid)	20 VA		20 VA		
Poids		150 g (sans broche)					
Tensions "Un"		V CA/Hz	Numéro de commande	V CC	Numéro de commande	V CA/Hz	Numéro de commande
entre -10 % et +10 % de Un pour CA		KT09 24/50	304621	KT10 12 CC	304666	KH09 24/50	304746
entre -5 % et +10 % de Un pour CC		KT09 115/50	304631	KT10 24 CC	304971	KH09 230/50	304748
		KT09 208-230/60	304656				
		KT09-230/50	304639				
		KT09 240/50	304641				

Pour commander une bobine : utilisez le numéro de commande à 6 chiffres - **Exemple de code** : KT10 pour 12 V CC = 304666
D'autres tensions possibles se trouvent dans le tableau des codes tension à la fin de la section des bobines.

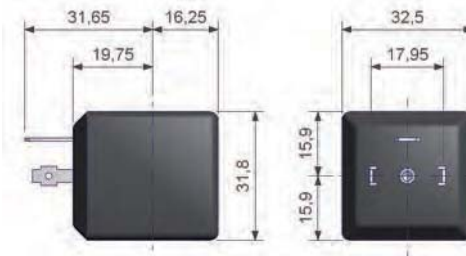

BOBINE DE LA SÉRIE XT09

Cette bobine peut être montée avec toutes les électrovannes Parker correspondant au groupe électrique spécifique.

Voir la colonne "Groupe électrique" sur les pages concernant les vannes.

Bobine fabriquée avec du fil de cuivre de classe H, moulée dans du polyester à base de matériaux thermoplastiques avec 30 % de fibre de verre. Indice de protection IP54 avec un connecteur spécial 2 P + T. Broche spéciale avec câble d'alimentation intégré disponible séparément.

Cette bobine est conforme aux normes de sécurité CEI/CENELEC ainsi qu'à la directive européenne Basse tension.

Connecteur à broches DIN à commander séparément (voir la section des accessoires de la bobine).



Caractéristiques		Pour les applications de chauffage	
Réf. (sans broche DIN)		XT09	
Groupe électrique		23.0	
Indice de protection		IP54 selon les normes CEI/EN 60529 (avec broche spéciale fournie séparément)	
Classe d'isolation		F 155 °C	
Raccordement électrique		Connecteur à broches spécial 2 P + T	
Température ambiante		entre -10 °C et +50 °C L'application est également limitée par la plage de température de la vanne.	
Alimentation électrique	CC	P (froid) 20 °C	-
	CA	P (froid) 20 °C	9 W
		Attraction (froid)	22 VA
Poids		150 g (sans broche)	
Tensions "Un"		V CA/Hz	Numéro de commande
entre -10 % et +10 % de Un pour CA		XT09 230/50	304776

Pour commander une bobine : utilisez le numéro de commande à 6 chiffres - **Exemple de code :** XT09 230/50 = 304776

D'autres tensions possibles se trouvent dans le tableau des codes tension à la fin de la section des bobines.

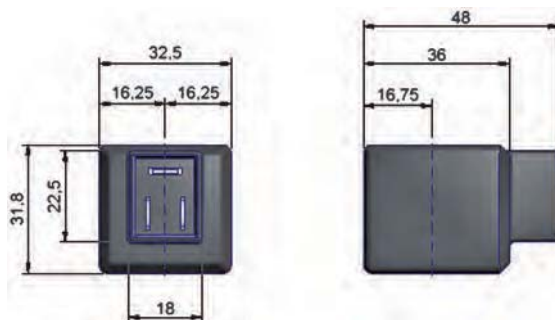

BOBINES POUR
CONNECTEUR
À BROCHES DIN

BOBINES DE LA SÉRIE D4, HOMOLOGUÉES UL, 32 mm

La bobine est homologuée UL et conforme à la norme d'isolation de Classe 155, aux normes de sécurité CEI/CENELEC et à la directive européenne Basse tension.

Connecteur à broches DIN à commander séparément (voir la section des accessoires de la bobine).



Caractéristiques		Homologuée UL			
Référence (sans broche DIN)		Série D4			
Groupe électrique		24.0			
Indice de protection		IP65 selon les normes CEI/EN 60529 (avec broche DIN)			
Classe d'isolation		F 155 °C			
Raccordement électrique		La bobine est raccordée à l'aide d'une broche 2 P + T selon EN 175301-803, type A.			
Température ambiante		entre -40 °C et +50 °C L'application est également limitée par la plage de température de la vanne.			
Alimentation électrique	CC	Pn (chaud)	16 W		
		P (froid) 20 °C	-		
	CA	Pn (maintien)	13 W		
		Attraction (froid)	40 VA		
Poids		130 g			
Tensions "Un"		V CA/Hz	Code	V CC	Code
entre -10 % et +10 % de Un pour CA		24/60 110/50 - 120/60 220/50 - 240/60	D4E D4F D4G	24	D4B

Pour commander une bobine : utilisez le numéro de commande à 6 chiffres - **Exemple de code :** D4 pour 24 V CA/60 Hz = **D4E**
D'autres tensions possibles se trouvent dans le tableau des codes tension à la fin de la section des bobines.

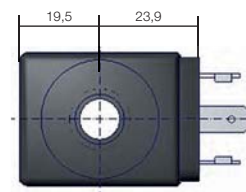
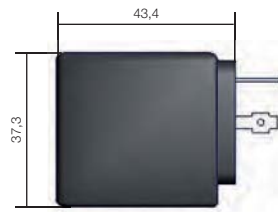
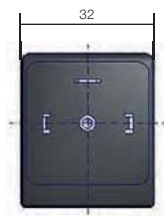



BOBINE DE LA SÉRIE D5, 32 mm

Enrobée dans un matériau synthétique, connecteur pour broche 2 P + T selon DIN EN 175301-803, forme A, l'indice de protection IP65 est valable avec la broche uniquement.

Cette bobine est conforme aux normes de sécurité CEI/CENELEC ainsi qu'à la directive européenne Basse tension.

Connecteur à broches DIN à commander séparément (voir la section des accessoires de la bobine).



Caractéristiques		Bobine VDE à simple fréquence			
Référence (sans broche DIN)		Série D5			
Groupe électrique		24.0			
Indice de protection		IP65 selon les normes CEI/EN 60529 (avec broche DIN)			
Classe d'isolation		F 155 °C			
Raccordement électrique		La bobine est raccordée à l'aide d'une broche 2 P + T selon EN 175301-803, type A.			
Température ambiante		entre -40 °C et +50 °C L'application est également limitée par la plage de température de la vanne.			
Alimentation électrique	CC	Pn (chaud)	9 W		
		P (froid) 20 °C	-		
	CA	P (froid) 20 °C	8 W		
		Attraction (froid)	40 VA		
Poids		130 g			
Tensions "Un" entre -10 % et +10 % de Un pour CA		V CA/Hz	Code	V CC	Code
		24/50	D5H	24	D5B
		110/50	D5XA5		
		220-230/50	D5L		
		24/60	D5E		
		230/60	D5XJ3		
		115/60	D5XK8		

Pour commander une bobine : utilisez le numéro de commande à 6 chiffres - **Exemple de code** : D5 pour 24 V CA/60 Hz = DSE
D'autres tensions possibles se trouvent dans le tableau des codes tension à la fin de la section des bobines.

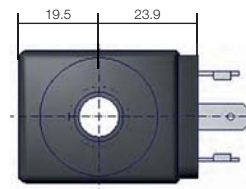
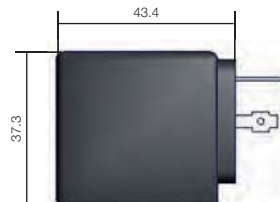

BOBINES POUR
CONNECTEUR
À BROCHES DIN

BOBINE DE LA SÉRIE XS03, 32 mm

Enrobée dans un matériau synthétique, connecteur pour broche 2 P + T selon DIN EN 175301-803, forme A, l'indice de protection IP65 est valable avec la broche uniquement.

Cette bobine est conforme aux normes de sécurité CEI/CENELEC ainsi qu'à la directive européenne Basse tension.

Connecteur à broches DIN à commander séparément (voir la section des accessoires de la bobine).



Caractéristiques		Bobine VDE à double fréquence	
Référence (sans broche DIN)		Série XS03	
Groupe électrique		24.0	
Indice de protection		IP65 selon les normes CEI/EN 60529 (avec broche DIN)	
Classe d'isolation		F 155 °C	
Raccordement électrique		La bobine est raccordée à l'aide d'une broche 2 P + T selon EN 175301-803, type A.	
Température ambiante		entre -40 °C et +50 °C L'application est également limitée par la plage de température de la vanne.	
Alimentation électrique	CC	Pn (chaud)	-
		P (froid) 20 °C	-
	CA	Pn (maintien)	9 W
		Attraction (froid)	32 VA
Poids		130 g	
Tensions "Un"		V CA/Hz	Code
entre -10 % et +10 % de Un pour CA		24/50 - 24/60	XS09XM
		110-115/50 - 120/60	XS03XS5
		220-240/50 - 240/60	XS03XS6

Pour commander une bobine : utilisez le numéro de commande à 6 chiffres - **Exemple de code :** XS03 pour 24/50-24/60 = **XS09XM**
D'autres tensions possibles se trouvent dans le tableau des codes tension à la fin de la section des bobines.

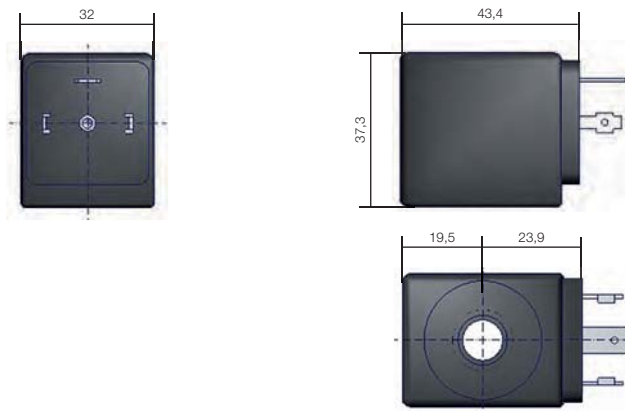



BOBINE POUR APPLICATION PETROCHIMIE, 37 mm

Cette bobine peut être montée avec toutes les électrovannes Parker correspondant au groupe électrique spécifique.

Voir la colonne "Groupe électrique" sur les pages concernant les vannes.

Ensemble enrobé comprenant une bobine, un circuit magnétique et une broche enfichable.

Le matériau synthétique enrobé permet de protéger l'ensemble compact contre la pénétration de corps étrangers (ex. : poussières, huile, eau, etc).

Montage facile dans les espaces confinés - Protection contre les chocs et la corrosion - Simplification du passage aux nouvelles exigences de l'équipement existant, etc.

Les bobines sont conformes aux normes de sécurité CEI/CENELEC ainsi qu'à la directive européenne Basse tension.

Connecteur à broches DIN à commander séparément (voir la section des accessoires de la bobine).



Caractéristiques		Bobine pour huile et gaz, 8 W			
Référence (avec broche DIN)		496895			
Groupe électrique		10.1			
Indice de protection		IP65			
Classe d'isolation		H 180 °C			
Raccordement électrique		Avec broche DIN 492459 (CA) ou 486586 (CC)			
Température ambiante		entre -40 °C et +50 °C L'application est également limitée par la plage de température de la vanne.			
Alimentation électrique	CC	Pn (chaud)	8 W		
		P (froid) 20 °C	-		
	CA	Pn (maintien)	8 W		
		Attraction (froid)	-		
Poids		273 g			
Tensions "Un"		V CA/Hz	Code	V CC	Code
entre -10 % et +10 % de Un		230/50-60	P9	24	C2
		110/50-60	P2	48	C4
		24/50-60	P0	110	C5
		48/50-60	S4		

Pour commander une bobine, choisissez la réf. bobine + le code tension, par exemple : 496895 pour 24 V CC = 496895C2
D'autres tensions possibles se trouvent dans le tableau des codes tension à la fin de la section des bobines.

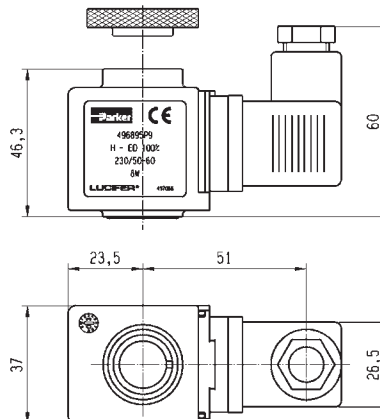



BOBINE DE LA SÉRIE YB, IP67

Ces bobines peuvent être montées avec toutes les électrovannes Parker correspondant au groupe électrique spécifique.

Voir la colonne "Groupe électrique" sur les pages concernant les vannes.

Bobine fabriquée avec du fil de cuivre de classe H, moulée dans du polyester à base de matériaux thermoplastiques avec 30 % de fibre de verre.
Indice de protection IP67. Raccordement électrique : 2 câbles de 1000 mm.

Cette bobine est conforme aux normes de sécurité CEI/CENELEC ainsi qu'à la directive européenne Basse tension.

Pour la version homologuée UL : fichier UL n° MH19410.



Caractéristiques		Standard		Version homologuée UL			
Référence		YB09/YB12		YB09			
Groupe électrique		20.1					
Indice de protection		IP67 selon les normes CEI/EN 60529					
Classe d'isolation		F 155 °C					
Raccordement électrique		La bobine est raccordée à l'aide des 2 câbles volants intégrés de 1000 mm.					
Température ambiante		entre -10 °C et +50 °C L'application est également limitée par la plage de température de la vanne.					
Alimentation électrique	CC	P (froid) 20 °C	12 W		-		
	CA	Pn (maintien)	9 W		9 W		
		Attraction (froid)	24 VA		24 VA		
Poids		150 g					
Tensions "Un"		V CA/Hz	Numéro de commande	V CC	Numéro de commande	V CA/Hz	Numéro de commande
entre -10 % et +10 % de Un pour CA entre -5 % et +10 % de Un pour CC.		YB09 115/50-60	304396	YB12 12 CC	304412	YB09 24/60	304481
		YB09 230/50-60	304398	YB12 24 CC	304416	YB09 110-120/60	304488
		YB09 24/50-60	304390			YB09 208-240/60	304483
		YB09 240/50-60	304400				

Pour commander une bobine : utilisez le numéro de commande à 6 chiffres - **Exemple de code** :

YB09 pour 24 V CA/60 Hz = **304481**

D'autres tensions possibles se trouvent dans le tableau des codes tension à la fin de la section des bobines.

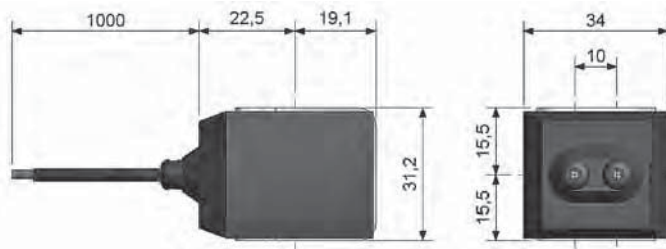



BOBINES DE LA SÉRIE LA, 32 mm, IP67

Enrobée dans un matériau synthétique. Indice de protection IP67 conformément à la norme CEI/EN60529.

Connexion : 2 câbles de 500 mm.

Cette bobine est conforme aux normes de sécurité CEI/CENELEC ainsi qu'à la directive européenne Basse tension.



Caractéristiques		Bobine avec deux câbles volants de 500 mm			
Référence		Série LA			
Groupe électrique		24.0			
Indice de protection		IP67 selon les normes CEI/EN 60529			
Classe d'isolation		F 155 °C			
Température ambiante		entre -10 °C et +50 °C L'application est également limitée par la plage de température de la vanne.			
Alimentation électrique	CC	Pn (chaud)	9 W		
		P (froid) 20 °C	-		
	CA	Pn (maintien)	9 W		
		Attraction (froid)	32 VA		
Poids		180 g			
Tensions "Un"		V CA/Hz	Code	V CC	Code
entre -10 % et +10 % de Un pour CA		24/50 - 24/60	LAM	24	LAB
		110-115/50 - 120/60	LAXS5		
		220-240/50 - 240/60	LAXS6		

Pour commander une bobine : utilisez le numéro de commande à 6 chiffres - **Exemple de code :** série LA pour 24 V CC = **LAB**
D'autres tensions possibles se trouvent dans le tableau des codes tension à la fin de la section des bobines.

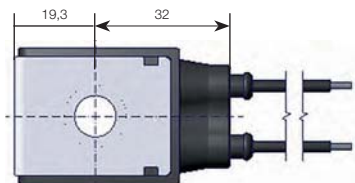
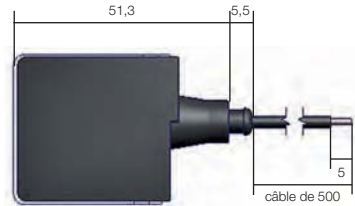
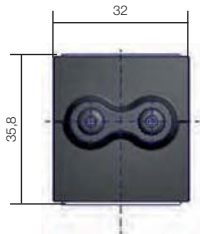

**BOBINE DE LA SÉRIE LB-LC, 32 mm, UL, IP67**

Enrobée dans un matériau synthétique. Indice de protection IP67 conformément à la norme CEI/EN60529.

Connexion : 2 câbles de 500 mm.

La bobine est homologuée UL et conforme à la norme d'isolation de Classe 155, aux normes de sécurité CEI/CENELEC et à la directive européenne Basse tension.



Caractéristiques		Bobine UL avec deux câbles volants de 500 mm			
Référence		Série LB-LC			
Groupe électrique		24.0			
Indice de protection		IP67 selon les normes CEI/EN 60529			
Classe d'isolation		F 155 °C			
Température ambiante		entre -10 °C et +50 °C L'application est également limitée par la plage de température de la vanne.			
Alimentation électrique	CC	Pn (chaud)	16 W		
		P (froid) 20 °C	-		
	CA	Pn (maintien)	13-14 W		
		Attraction (froid)	40 VA		
Poids		180 g			
Tensions "Un"		V CA/Hz	Code	V CC	Code
entre -10 % et +10 % de Un pour CA		24/60 110/50 - 120/60 208-240/60 220/50 240/60	LBE LBF LBU3 LBG	24	LCB

Pour commander une bobine : utilisez le numéro de commande à 6 chiffres - **Exemple de code :** série LB-LC pour 24 V CC = LCB
D'autres tensions possibles se trouvent dans le tableau des codes tension à la fin de la section des bobines.

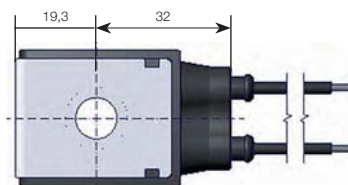
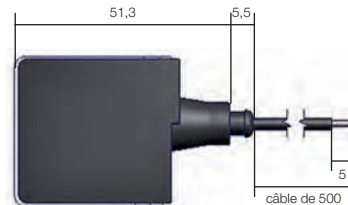
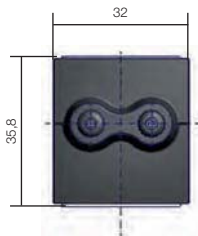

2.0/2.1

BOBINES AVEC CABLES VOLANTS



BOBINE IP67 DE 32 mm

Cette bobine peut être montée avec toutes les électrovannes Parker correspondant au groupe électrique spécifique.

Voir la colonne "Groupe électrique" sur les pages concernant les vannes.

Ensemble enrobé comprenant une bobine, un circuit magnétique et une broche enfichable.

Le matériau synthétique enrobé permet de protéger l'ensemble compact contre la pénétration de corps étrangers (ex. : poussières, huile, eau, etc).

Montage facile dans les espaces confinés - Protection contre les chocs et la corrosion - Simplification du passage aux nouvelles exigences de l'équipement existant, etc.

Les bobines sont conformes aux normes de sécurité CEI/CENELEC ainsi qu'à la directive européenne Basse tension.



Caractéristiques		Bobine avec deux câbles volants de 500 mm			
Référence		496081			
Groupe électrique		2.0/2.1			
Indice de protection		IP67 selon les normes CEI/EN 60529			
Classe d'isolation		F 155 °C			
Température ambiante		entre -40 °C et +50 °C L'application est également limitée par la plage de température de la vanne.			
Alimentation électrique	CC	Pn (chaud)	9 W		
		P (froid) 20 °C	-		
	CA	Pn (maintien)	9 W		
		Attraction (froid)	32 VA		
Poids		180 g			
Tensions "Un"		V CA/Hz	Numéro de commande	V CC	Numéro de commande
entre -10 % et +10 % de Un pour CA		24/50 - 24/60	439816	24	439818
		110-115/50 - 120/60	439820	12	439814
		220-240/50 - 240/60	439822		

Pour commander une bobine : utilisez le numéro de commande à 6 chiffres - **Exemple de code :** 496081 pour 24 V CC = 439818
D'autres tensions possibles se trouvent dans le tableau des codes tension à la fin de la section des bobines.

Pour les vannes Parker Lucifer®, commandez le boîtier Réf. : 2995

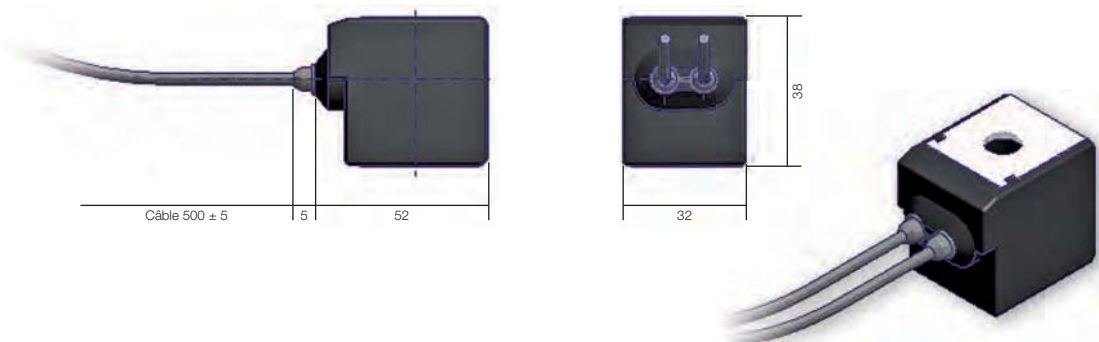



BOBINE IP67 UL DE 32 mm

Cette bobine peut être montée avec toutes les électrovannes Parker correspondant au groupe électrique spécifique.

Voir la colonne "Groupe électrique" sur les pages concernant les vannes.

Ensemble enrobé comprenant une bobine, un circuit magnétique et une broche enfichable.

Le matériau synthétique enrobé permet de protéger l'ensemble compact contre la pénétration de corps étrangers (ex. : poussières, huile, eau, etc).

Montage facile dans les espaces confinés - Protection contre les chocs et la corrosion - Simplification du passage aux nouvelles exigences de l'équipement existant, etc.

Les bobines sont conformes aux normes de sécurité CEI/CENELEC ainsi qu'à la directive européenne Basse tension.



Caractéristiques		Bobine UL avec deux câbles volants de 500 mm			
Référence		496082			
Groupe électrique		2.0/2.2			
Indice de protection		IP67 selon les normes CEI/EN 60529			
Classe d'isolation		F 155 °C			
Température ambiante		entre -40 °C et +120 °C L'application est également limitée par la plage de température de la vanne.			
Alimentation électrique	CC	Pn (chaud)	16 W		
		P (froid) 20 °C	-		
	CA	Pn (maintien)	13-14 W		
		Attraction (froid)	40 VA		
Poids		180 g			
Tensions "Un"		V CA/Hz	Numéro de commande	V CC	Numéro de commande
entre -10 % et +10 % de Un pour CA		24/60	439826	24	439832
		110/50 - 120/60	439828		
		208-240/60	439824	12	439830
		220/50 - 240/60	439834		

Pour commander une bobine : utilisez le numéro de commande à 6 chiffres - Exemple de code : 496082 pour 24 V CC = 439832
D'autres tensions possibles se trouvent dans le tableau des codes tension à la fin de la section des bobines.

Pour les vannes Parker Lucifer®, commandez le boîtier Réf. : 2995

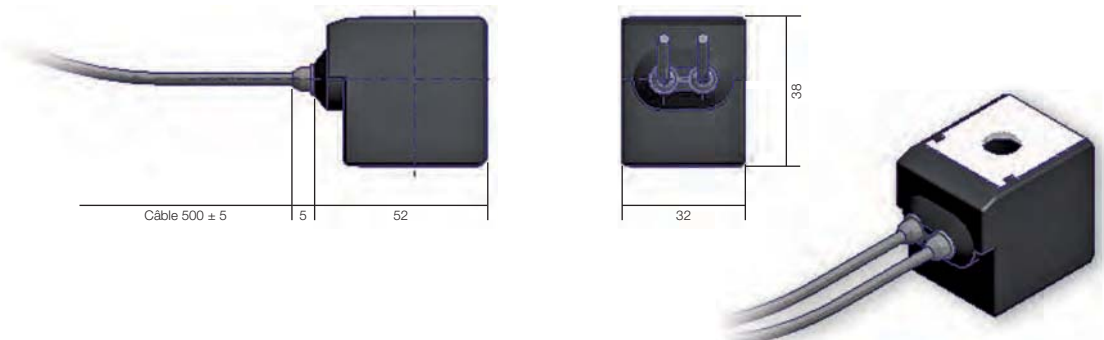



BOBINES STANDARD 40 mm

Ces bobines peuvent être montées avec toutes les électrovannes Parker correspondant au groupe électrique spécifique.

Voir la colonne "Groupe électrique" sur les pages concernant les vannes.

Les bobines peuvent être montées avec tous les boîtiers métalliques.

Le bobinage est entièrement enrobé dans un matériau synthétique.

Montage facile dans les espaces confinés. Raccordement électrique avec des bornes à vis pour des fils jusqu'à 1,5 mm².

Les bobines sont conformes aux normes de sécurité CEI/CENELEC ainsi qu'à la directive européenne Basse tension.



Caractéristiques		Standard			Double fréquence		
Référence		481000			483520		
Groupe électrique		2.0/2.1					
Classe d'isolation		F 155 °C					
Température ambiante		entre -40 °C et +50 °C L'application est également limitée par la plage de température de la vanne.					
Alimentation électrique	CC	Pn (chaud)	8 W		-		
		P (froid) 20 °C	9 W		-		
	CA	Pn (maintien)	8 W		9 W		
		Attraction (froid)	32 VA (9 W)		36 VA (10 W)		
Poids		130 g			130 g		
Tensions "Un"		V CA/Hz	Code	V CC	Code	V CA/Hz	Code
entre -10 % et +10 % de Un		24/50	A2	24	C2	24/50-60	P0
		48/50	A4	48	C4	48/50-60	S4
(Entre -15 % et +5 % pour une bobine à double fréquence avec code tension		110/50-115/50	0A	110	C5	110-115/50-120/60	S5
S6 en cas d'utilisation de 240 V/50/Hz).		220/50-230/50	3D			220-240/50-240/60	S6

Pour commander une bobine, choisissez la réf. bobine + le code tension, par exemple : 481000 pour 24 V CC = **481000C2**
D'autres tensions possibles se trouvent dans le tableau des codes tension à la fin de la section des bobines.

Ces bobines doivent être utilisées avec les boîtiers adaptés. Voir les exemples ci-dessous :

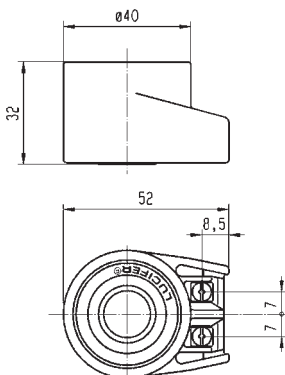

Réf 4270 - Protection IP 44



Réf. 4538 - Protection IP 67

BOBINES HAUTE PUISSANCE 40 mm

Cette bobine peut être montée avec toutes les électrovannes Parker correspondant au groupe électrique spécifique.

Voir la colonne "Groupe électrique" sur les pages concernant les vannes.

Les bobines peuvent être montées avec tous les boîtiers métalliques.

Le bobinage est entièrement enrobé dans un matériau synthétique.

Montage facile dans les espaces confinés. Raccordement électrique avec des bornes à vis pour des fils jusqu'à 1,5 mm².

Les bobines sont conformes aux normes de sécurité CEI/CENELEC ainsi qu'à la directive européenne Basse tension.



Caractéristiques		Haute puissance	
Référence		481044	
Groupe électrique		2.0/2.2	
Classe d'isolation		F 155 °C	
Température ambiante		entre -40 °C et +50 °C L'application est également limitée par la plage de température de la vanne.	
Alimentation électrique	CC	Pn (chaud)	-
		P (froid) 20 °C	-
CA		Pn (maintien)	14 W
		Attraction (froid)	56 VA (20 W)
Poids		130 g	
Tensions "Un"		V CA/Hz	Code
entre -10 % et +10 % de Un		24/50	A2
		110/50	A5
		220/50	A7
		230/50	F4

Pour commander une bobine, choisissez la réf. bobine + le code tension, par exemple : 481044 pour 24 V CA/50 Hz = 481044A2
D'autres tensions possibles se trouvent dans le tableau des codes tension à la fin de la section des bobines.

Ces bobines doivent être utilisées avec les boîtiers adaptés. Voir les exemples ci-dessous :

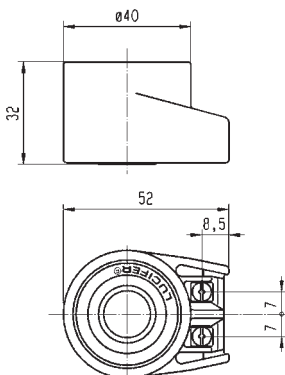

Réf. 4270 - Protection IP 44



Réf. 8520 - Protection IP 67

BOBINES HAUTE TEMPÉRATURE 40 mm

Ces bobines peuvent être montées avec toutes les électrovannes Parker correspondant au groupe électrique spécifique.

Voir la colonne "Groupe électrique" sur les pages concernant les vannes.

Les bobines peuvent être montées avec tous les boîtiers métalliques.

Le bobinage est entièrement enrobé dans un matériau synthétique.

Montage facile dans les espaces confinés. Raccordement électrique avec des bornes à vis pour des fils jusqu'à 1,5 mm².

Les bobines sont conformes aux normes de sécurité CEI/CENELEC ainsi qu'à la directive européenne Basse tension.



Caractéristiques		Haute température			Haute température et haute puissance				
Référence		485100			486265				
Groupe électrique		2.0/2.1			2.0/2.2				
Classe d'isolation		H 180 °C							
Température ambiante		entre -40 °C et +50 °C L'application est également limitée par la plage de température de la vanne.							
Alimentation électrique	CC	Pn (chaud)	8 W		14 W				
		P (froid) 20 °C	9 W		21 W				
	CA	Pn (maintien)	8 W		14 W				
		Attraction (froid)	32 VA (9 W)		56 VA (20 W)				
Poids		140 g							
Tensions "Un"		V CA/Hz	Code	V CC	Code	V CA/Hz	Code	V CC	Code
entre -10 % et +10 % de Un		24/50	A2	24	C2	24/50	A2	12	C1
		220/50-230/50	3D	125	3N	110/50	A5	24	C2
				220	C7	220/50	A7	48	C4
				230/50	F4				

Pour commander une bobine, choisissez la réf. bobine + le code tension, par exemple : 485100 pour 24 V CA/50 Hz = 485100A2
D'autres tensions possibles se trouvent dans le tableau des codes tension à la fin de la section des bobines.

Ces bobines doivent être utilisées avec les boîtiers adaptés. Voir les exemples ci-dessous :

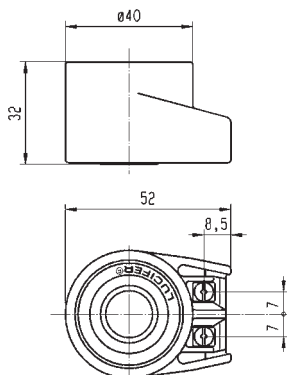

Réf. 4270 - Protection IP 44



Réf. 8520 - Protection IP 67

BOBINES HAUTE TEMPÉRATURE ET HAUTE PUISSANCE 40 mm BRÛLEUR À MAZOUT

Ces bobines peuvent être montées avec toutes les électrovannes Parker correspondant au groupe électrique spécifique.

Voir la colonne "Groupe électrique" sur les pages concernant les vannes.

Les bobines peuvent être montées avec tous les boîtiers métalliques.

Le bobinage est entièrement enrobé dans un matériau synthétique.

Montage facile dans les espaces confinés. Raccordement électrique avec des bornes à vis pour des fils jusqu'à 1,5 mm².

Les bobines sont conformes aux normes de sécurité CEI/CENELEC ainsi qu'à la directive européenne Basse tension.

Cette gamme de bobines n'est utilisée que dans un environnement conformément aux normes DIN/EN/ISO 23551-1:2009-10 (brûleurs de mazout).



Caractéristiques		Haute température et haute puissance		
Référence		483824	483541	
Groupe électrique		14.1		
Classe d'isolation		H 180 °C		
Température ambiante		entre -40 °C et +50 °C L'application est également limitée par la plage de température de la vanne.		
Alimentation électrique	CC	Pn (chaud)	19 W	20 W
		P (froid) 20 °C	19 W	20 W
	CA	Pn (maintien)	19 W	20 W
		Attraction (froid)	56 VA (20 W)	56 VA (20 W)
Poids		130 g		
Tensions "Un"		V CA/Hz	Code	
entre -10 % et +10 % de Un		110/60 115/50-120/60 230/50-240/60	B5 P8 T1	

Pour commander une bobine, choisissez la réf. bobine + le code tension, par exemple : 483541 pour 110/60 V CA/Hz = 483541B5

D'autres tensions possibles se trouvent dans le tableau des codes tension à la fin de la section des bobines.

Ces bobines doivent être utilisées avec les boîtiers adaptés (Réf. : 8760.24 et Réf. : 8520.23)

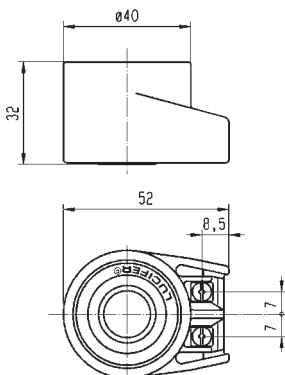

Réf. 8760.24



Réf. 8520.23



BOBINE À DOUBLE FRÉQUENCE 40 mm CLASSE H

Cette bobine peut être montée avec toutes les électrovannes Parker correspondant au groupe électrique spécifique.

Voir la colonne "Groupe électrique" sur les pages concernant les vannes.

Les bobines peuvent être montées avec tous les boîtiers métalliques.

Le bobinage est entièrement enrobé dans un matériau synthétique.

Montage facile dans les espaces confinés. Raccordement électrique avec des bornes à vis pour des fils jusqu'à 1,5 mm².

Les bobines sont conformes aux normes de sécurité CEI/CENELEC ainsi qu'à la directive européenne Basse tension.



Caractéristiques		Double fréquence 100 V - 200 V	
Référence		488553	
Groupe électrique		2.0/2.1	
Classe d'isolation		H 180 °C	
Température ambiante		entre -40 °C et +50 °C L'application est également limitée par la plage de température de la vanne.	
Alimentation électrique	CC	Pn (chaud)	-
		P (froid) 20 °C	-
	CA	Pn (maintien)	9 W
		Attraction (froid)	-
Poids		130 g	
Tensions "Un"		V CA/Hz	Code
entre -10 % et +10 % de Un		100/50-60	P1
		200/50-60	P6

Pour commander une bobine, choisissez la réf. bobine + le code tension, par exemple : 488553 pour 110/50-60 = 488553P1
D'autres tensions possibles se trouvent dans le tableau des codes tension à la fin de la section des bobines.

Ces bobines doivent être utilisées avec les boîtiers adaptés. Voir les exemples ci-dessous :

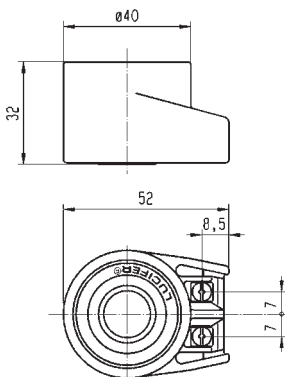

Réf. 4270 - Protection IP 44



Réf. 2985 - Protection IP 54

BOBINES BISTABLES 40 mm POUR LES APPLICATIONS AIMPULSIONS

Ces bobines peuvent être montées avec toutes les électrovannes Parker correspondant au groupe électrique spécifique.

Voir la colonne "Groupe électrique" sur les pages concernant les vannes.

Ces bobines ont été spécialement conçues pour des électrovannes Lucifer® bistables (ou à impulsion ou à verrouillage magnétique) pour les applications de chauffage.

Elles ne peuvent être montées qu'avec le boîtier métallique 4269 de Lucifer®.

Le bobinage est entièrement enrobé dans un matériau synthétique.

Montage facile dans les espaces confinés. Raccordement électrique avec des bornes à vis pour des fils jusqu'à 1,5 mm².

Les bobines sont conformes aux normes de sécurité CEI/CENELEC ainsi qu'à la directive européenne Basse tension.



Caractéristiques		Bistable (Impulsion)			
Référence		484990		485400	
Groupe électrique		4.0			
Classe d'isolation		F 155 °C			
Température ambiante		entre -40 °C et +50 °C L'application est également limitée par la plage de température de la vanne.			
Longueur des impulsions		Enclenchement (bornes A-B) : 50 ms minimum Déclenchement (bornes A-C) : 35 ms minimum			
Consommation électrique	CC	Attraction (chaud)		-	13 W
		Attraction (froid)		-	19 W
		Relâchement (chaud)		-	8 W
		Relâchement (froid)		-	10 W
	CA	Attraction (chaud)		11 W	-
		Attraction (froid)		17 W	-
		Relâchement (chaud)		4 W	-
		Relâchement (froid)		7 W	-
Poids		150 g			
Tensions "Un"		V CA/Hz	Code	V CC	Code
entre -10 % et +10 % de Un		24/50-24/60	P0	24	C2
		48/50-48/60	S4	48	C4
		110-115/50-115/60	1P	110	C5
		220-230/50-60	3P		

Pour commander une bobine, choisissez la réf. bobine + le code tension, par exemple : 485400 pour 24 V CC = 485400C2

D'autres tensions possibles se trouvent dans le tableau des codes tension à la fin de la section des bobines.

Ces bobines doivent être utilisées avec les boîtiers adaptés.

Voir les exemples ci-dessous :

SCHÉMA

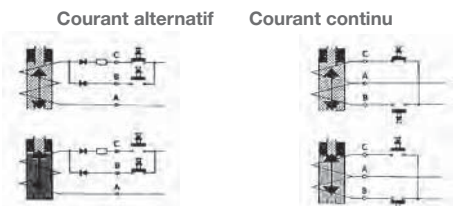

Seule une impulsion électrique donnée aux bornes A-C conserve le champ magnétique. Ce champ magnétique démagnétise suffisamment l'aimant réversible pour permettre au ressort de rappel de remettre le plongeur dans sa position d'origine et de fermer la vanne.



Réf. 4269 - Protection IP 44



Réf. 4538 - Protection IP 67

BOBINES 12 V À 24 V POUR LES APPLICATIONS DANS LE DOMAINE DU TRANSPORT, 32 mm

Ces bobines peuvent être montées avec toutes les électrovannes Parker correspondant au groupe électrique spécifique. Voir la colonne "Groupe électrique" sur les pages concernant les vannes.

Ces bobines ont été spécialement conçues pour des électrovannes Lucifer® pour les applications dans le domaine du transport. Elles peuvent être montées avec le boîtier 2161 standard de Lucifer® ou un boîtier personnalisé.

Le bobinage est entièrement enrobé dans un matériau époxy. Montage et démontage facile dans les espaces confinés. Fermeture à baïonnette pour un raccordement ferme et résistant aux vibrations.

Les bobines sont conformes aux normes de sécurité CEI/CENELEC ainsi qu'à la directive européenne Basse tension.



Caractéristiques		Transport			
Référence		496193		495294	
Groupe électrique		13.0			
Indice de protection		IP69K conformément à la norme DIN 40050, partie 9			
Température ambiante		entre - 40 °C et +120 °C L'application est également limitée par la plage de température de la vanne et son cycle de fonctionnement.			
Classe d'isolation		F 155 °C			
Raccordement électrique		ISO 15170-A1-2.3-Sn/K2		DIN 72585-A3-2.1	
Alimentation électrique	CC	Pn (chaud)	9 w		
		P (froid) 20 °C	-		
	CA	Pn (maintien)	-		
		Attraction (froid)	-		
Poids		147 g			
Tensions "Un"		V CC	Code	V CC	Code
entre -30 % et +30 % de Un		12	C1	12	C1
		24	C2	24	C2

Pour commander une bobine, choisissez la réf. bobine + le code tension, par exemple 496193 pour 24 V CC = 496193C2

Ces bobines doivent être utilisées avec les boîtiers adaptés (Réf. :2161).

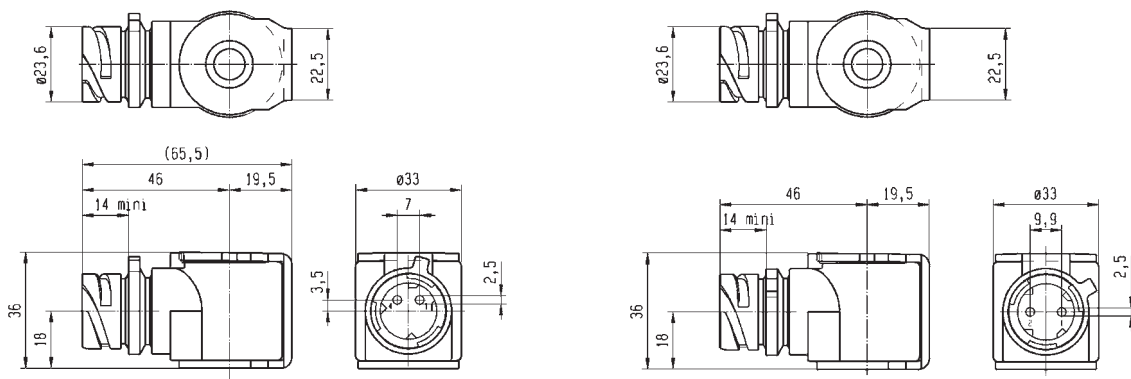

SOMMAIRE

INTRODUCTION

Index par référence de bobine.....	446
Index par groupe électrique.....	448
Index pour les parties électriques antidéflagrantes.....	450
Liste des groupes électrique.....	451

BOBINES

Bobines pour connecteur à broches DIN.....	454
Bobines avec câbles volants.....	477
Bobines avec bornes à vis.....	482
Bobines avec connecteur ISO-DIN.....	488

PARTIES ÉLECTRIQUES ANTIDÉFLAGRANTES

Niveau de protection "nc AC".....	490
Niveau de protection "db".....	498
Niveau de protection "mb".....	499
Niveau de protection "db mb".....	504
Niveau de protection "eb".....	509
Niveau de protection "ia".....	513

BOÎTIERS.....	522
---------------	-----

ACCESSOIRES DE BOBINE.....	526
----------------------------	-----

ENVIRONNEMENTS EXPLOSIFS.....	528
-------------------------------	-----

ANNEXES POUR BOBINES

Tableau informatif pour les barrières IS.....	538
Tableau des codes tension pour les bobines et les parties électriques.....	540

PARTIE ÉLECTRIQUE À FAIBLE PUISSANCE 22 mm

Cette bobine peut être montée avec toutes les électrovannes Parker ATEX correspondant au groupe électrique spécifique.

Voir la colonne "Groupe électrique" sur les pages concernant les vannes.

Application :

Contrôle des électrovannes dans un endroit dangereux nécessitant une protection antidéflagration Ex nc AC IIC T5.

Avantages :

Le matériau synthétique enrobé de la bobine permet de protéger l'ensemble compact contre la pénétration de corps étrangers (ex. : poussière, huile, eau, etc).

Petite taille pour un montage facile dans les espaces confinés.



Référence		495865			
Certificat		LCIE 05 ATEX 6003 X			
Groupe électrique		1.1			
Type de protection	Gaz	II 3 G - Ex nc AC IIC T5			
	Poussières	II 3 D - Ex tc IIIC - T 95°C			
Indice de protection		IP65 (avec broche) selon CEI/EN 60529			
Température ambiante		entre -40 °C et +50 °C L'application est également limitée par la plage de température de la vanne.			
Classe d'isolation		F 155 °C			
Raccordement électrique		Bobines avec raccordement 2 P + T - lors du montage avec une broche Pg 9 fournie (fournie avec la bobine)			
Alimentation électrique	CC	Pn (chaud)	2,5 W		
		P (froid) 20 °C	3 W		
	CA	Pn (maintien)	2 W		
		Attraction (froid)	5,7 VA (2,5 W)		
Poids		120 g			
Tensions "Un"		V CA/Hz	Code	V CC	Code
entre -10 % et +10 % de Un		24/50	A2	24	C2
		48/50	A4	48	C4
		110/50-115/50	0A	110	C5
		220/50-230/50	3D		

Pour commander une bobine, choisissez la réf. bobine + le code tension, par exemple : 495865 pour 24 V CC = 495865C2

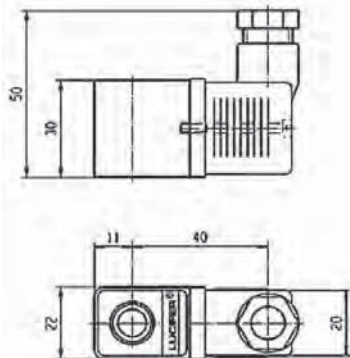



PARTIE ELECTRIQUE DOUBLE FREQUENCE 22 mm

Cette bobine peut être montée avec toutes les électrovannes Parker ATEX correspondant au groupe électrique spécifique.

Voir la colonne "Groupe électrique" sur les pages concernant les vannes.

Application :

Contrôle des électrovannes dans un endroit dangereux nécessitant une protection antidéflagration Ex nc AC IIC T5.

Avantages :

Le matériau synthétique enrobé de la bobine permet de protéger l'ensemble compact contre la pénétration de corps étrangers (ex. : poussière, huile, eau, etc).

Petite taille pour un montage facile dans les espaces confinés.



Caractéristiques		Double fréquence			
Référence		496637			
Certificat		ATEX			
Groupe électrique		1.2			
Type de protection	Gaz	-			
	Poussières	II 3 D - Ex tc IIIC - T 95°C			
Indice de protection		IP65 (avec broche) selon CEI/EN 60529			
Température ambiante		entre -40 °C et +50 °C L'application est également limitée par la plage de température de la vanne.			
Classe d'isolation		F 155 °C			
Alimentation électrique	CC	Pn (chaud)	3 W		
		P (froid) 20 °C	-		
	CA	Pn (maintien)	3 W		
		Attraction (froid)	5,7 VA (2,5 W)		
Poids		75 g			
Tensions "Un"		V CA/Hz	Code	V CC	Code
entre -10 % et +10 % de Un		24/50-60	P0	24 V	C2
		110/50-60	P2	48 V	C4
		230/50-60	P9	110 V	C5
		48/50-60	S4		

Pour commander une bobine, choisissez la réf. bobine + le code tension, par exemple : 496637 pour 24 V CC = 496637C2

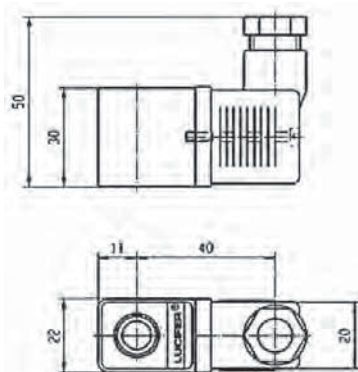

PARTIE ÉLECTRIQUE 32 mm

Ces bobines peuvent être montées avec toutes les électrovannes Parker ATEX correspondant au groupe électrique spécifique.

Voir la colonne "Groupe électrique" sur les pages concernant les vannes.

Application : contrôle des électrovannes dans un endroit dangereux nécessitant une protection antidéflagration Ex nc AC IIC T3 à T6.

Montage facile dans les espaces confinés - Protection contre les chocs et la corrosion - Simplification du passage aux nouvelles exigences de l'équipement existant, etc. Les bobines sont conformes aux normes de sécurité CEI/CENELEC ainsi qu'à la directive européenne Basse tension.

Petite taille pour un montage facile dans les espaces confinés.



Référence		495870			496110		
Certificat		LCIE 05 ATEX 6003 X					
Groupe électrique		2.0/2.1					
Type de protection	Gaz	II 3 G - Ex nc AC IIC T3 / T4			II 3 G - Ex nc AC IIC T3 / T4		
	Poussières	II 3 D - Ex tc IIIC - T195°C / T130°C			II 3 D - Ex tc IIIC - T195°C / T130°C		
Indice de protection		IP65 (avec broche) selon CEI/EN 60529					
Classe d'isolation		F (155 °C)					
Cycle de fonctionnement		100 %					
Température ambiante		entre -40 °C et +50 °C L'application est également limitée par la plage de température de la vanne.					
Alimentation électrique	CC	Pn (chaud)	9 W			-	
		P (froid) 20 °C	12 W			-	
	CA	Pn (maintien)	8 W			9 W	
		Attraction (froid)	26 VA (9 W)			32 VA (10 W)	
Poids		150 g					
Tensions "Un"		V CA/Hz	Code	V CC	Code	V CA/Hz	Code
entre -10 % et +10 % de Un		24/50	A2	24	C2	24/50-60	P0
		48/50	A4	48	C4	48/50-60	S4
		110/50	A5	110	C5	110/50-60	S5
		220-230/50	3D			220/50-60	S6

Pour commander une bobine, choisissez la réf. bobine + le code tension, par exemple : 495870 pour 24 V CC = 495870C2

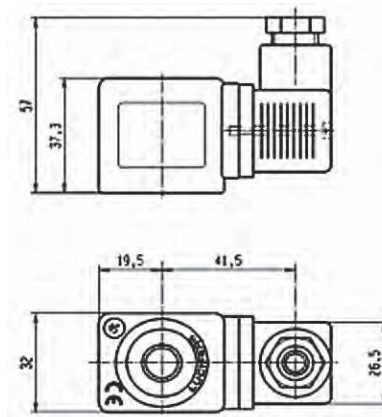



PARTIE ÉLECTRIQUE À FAIBLE PUISSANCE 32 mm

Cette bobine peut être montée avec toutes les électrovannes Parker ATEX correspondant au groupe électrique spécifique.

Voir la colonne "Groupe électrique" sur les pages concernant les vannes.

Application : contrôle des électrovannes dans un endroit dangereux nécessitant une protection antidéflagration Ex nc AC IIC T3 à T6.

Montage facile dans les espaces confinés - Protection contre les chocs et la corrosion - Simplification du passage aux nouvelles exigences de l'équipement existant, etc. Les bobines sont conformes aux normes de sécurité CEI/CENELEC ainsi qu'à la directive européenne Basse tension.

Petite taille pour un montage facile dans les espaces confinés.



Référence	496125		
Certificat	LCIE 05 ATEX 6003 X		
Groupe électrique	6.0		
Type de protection	Gaz	II 3 G - Ex nc AC IIC T5 / T6	
	Poussières	II 3 D - Ex tc IIIC - T80°C / T95°C	
Indice de protection	IP65 (avec broche) selon CEI/EN 60529		
Classe d'isolation	F (155 °C)		
Cycle de fonctionnement	100 %		
Température ambiante	entre -40 °C et +50 °C L'application est également limitée par la plage de température de la vanne.		
Alimentation électrique	CC	Pn (chaud)	1,6 W
		P (froid) 20 °C	2,1 W
	CA	Pn (maintien)	-
		Attraction (froid)	-
Poids	150 g		
Tensions "Un"	V CC	Code	
entre -10 % et +10 % de Un	24	C2	
	48	C4	
	110	C5	

Pour commander une bobine, choisissez la réf. bobine + le code tension, par exemple : 496125 pour 24 V CC = 496125C2

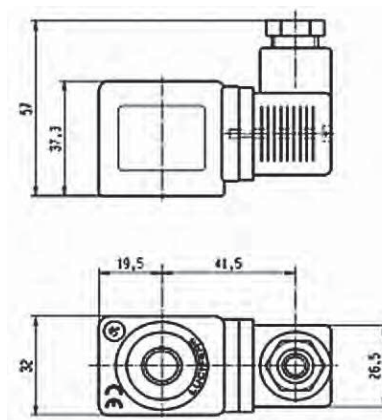

PARTIE ÉLECTRIQUE 32 mm

Cette bobine peut être montée avec toutes les électrovannes Parker ATEX correspondant au groupe électrique spécifique.
Voir la colonne "Groupe électrique" sur les pages concernant les vannes.

Application : contrôle des électrovannes dans un endroit dangereux nécessitant une protection antidéflagration Ex nc AC IIC T3 à T6.

Montage facile dans les espaces confinés - Protection contre les chocs et la corrosion - Simplification du passage aux nouvelles exigences de l'équipement existant, etc. Les bobines sont conformes aux normes de sécurité CEI/CENELEC ainsi qu'à la directive européenne Basse tension.

Petite taille pour un montage facile dans les espaces confinés.



Caractéristiques		Bobine 32 mm "nc AC"			
Référence		495875			
Certificat		LCIE 05 ATEX 6003 X			
Groupe électrique		2.0/2.1			
Type de protection	Gaz	II 3 G - Ex nc AC IIC T3 / T4			
	Poussières	II 3 D - Ex tc IIIC - T195°C / T130°C			
Indice de protection		IP65 (avec broche) selon CEI/EN 60529			
Classe d'isolation		F 155 °C			
Cycle de fonctionnement		100 %			
Température ambiante		entre -40 °C et +50 °C L'application est également limitée par la plage de température de la vanne.			
Alimentation électrique	CC	Pn (chaud)	7 W		
		P (froid) 20 °C	-		
	CA	Pn (maintien)	6 W		
		Attraction (froid)	-		
Poids		180 g			
Tensions "Un"		V CA/Hz	Code	V CC	Code
entre -10 % et +10 % de Un		220-230/50	3D	24	C2

Pour commander une bobine, choisissez la réf. bobine + le code tension, par exemple : 495875 pour 24 V CC = 495875C2

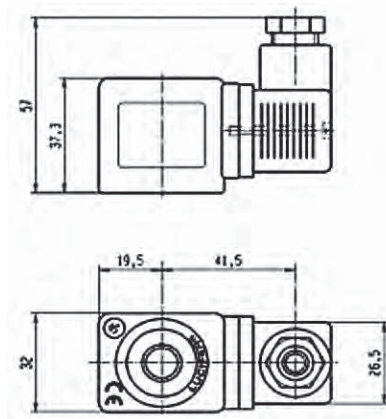



PARTIE ÉLECTRIQUE 32 mm

Cette bobine peut être montée avec toutes les électrovannes Parker ATEX correspondant au groupe électrique spécifique.

Voir la colonne "Groupe électrique" sur les pages concernant les vannes.

Application : contrôle des électrovannes dans un endroit dangereux nécessitant une protection antidéflagration Ex nc AC IIC T3 à T6.

Montage facile dans les espaces confinés - Protection contre les chocs et la corrosion - Simplification du passage aux nouvelles exigences de l'équipement existant, etc. Les bobines sont conformes aux normes de sécurité CEI/CENELEC ainsi qu'à la directive européenne Basse tension.

Petite taille pour un montage facile dans les espaces confinés.



Caractéristiques		Bobine 32 mm "nc AC"			
Référence		495880			
Certificat		LCIE 05 ATEX 6003X			
Groupe électrique		2.0/2.2			
Type de protection	Gaz	II 3 G - Ex nc AC IIC T3 65°C			
	Poussières	II 3D - Ex tc IIIC - T195°C			
Indice de protection		IP65 (avec broche) selon CEI/EN 60529			
Classe d'isolation		H 180°C			
Cycle de fonctionnement		100 %			
Température ambiante		entre -40 °C et +50 °C L'application est également limitée par la plage de température de la vanne.			
Alimentation électrique	CC	Pn (chaud)	14 W		
		P (froid) 20 °C	-		
	CA	Pn (maintien)	14 W		
		Attraction (froid)	-		
Poids		180 g			
Tensions "Un"		V CA/Hz	Code	V CC	Code
entre -10 % et +10 % de Un		24/50	A2	24	C2
		110/50	A5		
		230/50	F4		

Pour commander une bobine, choisissez la réf. bobine + le code tension, par exemple : 495880 pour 24 V CC = 495880C2

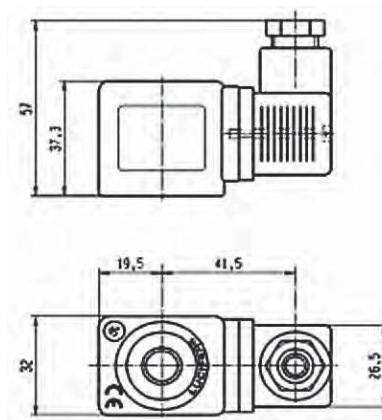

495915 - PARTIES ÉLECTRIQUES 50 mm

Cette bobine peut être montée avec toutes les électrovannes Parker ATEX correspondant au groupe électrique spécifique.

Voir la colonne "Groupe électrique" sur les pages concernant les vannes.

Application : contrôle des électrovannes dans un endroit dangereux nécessitant une protection antidéflagration - Ex nc AC IIC T3.

Avantages : boîtier orientable 360 °, acier trempé avec bornes à vis internes et externes pour une mise à la terre.

Petite taille pour un montage facile dans les espaces confinés. Simplification du passage de l'équipement existant aux nouvelles exigences des lieux à risque.



Référence		495915			
Certificat		LCIE 05 ATEX 6010 X			
Groupe électrique		4.0			
Type de protection	Gaz	II 3 G - Ex nc AC IIC T3			
	Poussières	II 3 D - Ex tc IIC - T 195°C			
Température ambiante		entre -40 °C et +65 °C L'application est également limitée par la plage de température de la vanne.			
Classe d'isolation		F 155 °C			
Raccordement électrique		Par presse-étoupe spécial M20 x 1,5 "ex eb" sur les bornes à vis pour les fils jusqu'à 1,5 mm ² . Le câble ayant un diamètre extérieur allant de 6,5 mm à 13,5 mm peut simplement être scellé en utilisant un presse-étoupe en caoutchouc avec les bagues d'étanchéité élastiques fournies			
Consommation électrique	CA	Attraction (chaud)	11 W	-	
		Attraction (froid) 20 °C	17 W	-	
		Relâchement (chaud)	4 W	-	
		Relâchement (froid) 20 °C	7 W	-	
	CC	Attraction (chaud)	-	13 W	
		Attraction (froid) 20 °C	-	19 W	
		Relâchement (chaud)	-	8 W	
		Relâchement (froid) 20 °C	-	10 W	
Poids		320 g			
Tensions "Un"		V CA/Hz	Code	V CC	Code
entre -10 % et +10 % de Un		110-115/50-60	1P	24	C2
		220-230/50-60	3P	48	C4
		48/50-60	S4		
		24/50-60	P0		
Cycle de fonctionnement		Électrovanne en fonctionnement continu (ED 100 %)			

Pour commander une bobine, choisissez la réf. bobine + le code tension,
par exemple : 495915 pour 24 V CC = **495915C2**

Schéma



Dès qu'une impulsion électrique est donnée aux bornes A-B, la force électromagnétique attire le plongeur et magnétise en même temps une bague aimante permanente réversible. Cet aimant tient le plongeur en place. Il reste dans sa position, même sans courant. Seule une impulsion électrique donnée aux bornes A-C conserve le champ magnétique. Ce champ magnétique démagnétise suffisamment l'aimant réversible pour permettre au ressort de rappel de remettre le plongeur dans sa position d'origine et de fermer la vanne.

Commutateur : enclenchement (bornes A-B) : 50 ms minimum (1 s maxi.)

CA : déclenchement (bornes A-C) : 35 ms minimum (1 s maxi.)

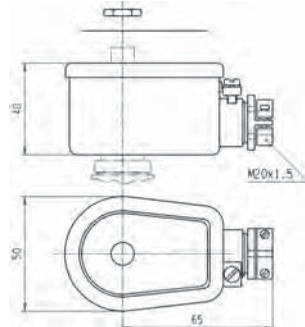



3.5.1 PARTIES ÉLECTRIQUES 496155

Ces bobines peuvent être montées avec toutes les électrovannes Parker correspondant au groupe électrique spécifique.

Voir la colonne "Groupe électrique compatibles" sur les pages concernant les vannes.

Application : contrôle des électrovannes dans un endroit dangereux nécessitant une protection antidéflagration Ex nAC IIC T3.

Avantages : boîtier orientable 360 °, acier trempé avec bornes à vis internes et externes pour une mise à la terre.

Petite taille pour un montage facile dans les espaces confinés. Simplification du passage de l'équipement existant aux nouvelles exigences des lieux à risque.



Référence		496155			
Certificat		LCIE 05 ATEX 6010 X			
Groupe électrique		2.0/2.2			
Type de protection	Gaz	II 3 G D - Ex nc AC IIC T3			
	Poussières	II 3 G D - Ex tc IIIC - T 195 °C			
Indice de protection		IP67			
Température ambiante		entre -40 °C et +65 °C L'application est également limitée par la plage de température de la vanne.			
Classe d'isolation		F 155 °C			
Raccordement électrique		Par presse-étoupe spécial ou M20 x 1,5 "Ex nc AC" sur les bornes à vis pour les fils jusqu'à 1,5 mm ² . Les câbles ayant un diamètre extérieur allant de 6,5 mm à 13,5 mm peuvent simplement être scellés en utilisant un presse-étoupe en caoutchouc avec les bagues d'étanchéité élastiques fournies.			
Alimentation électrique	CC	Pn (chaud)	14 W		
		P (froid) 20 °C	21 W		
	CA	Pn (maintien)	14 W		
		Attraction (froid)	56 VA (20 W)		
Poids		320 g			
Tensions "Un"		V CA/Hz	Code	V CC	Code
entre -10 % et +10 % de Un		24/50	A2	24	C2
		110/50	A5	48	C4
		230/50	F4		

Pour commander une bobine, choisissez la réf. bobine + le code tension, par exemple : 496155 pour 24 V CA/50Hz = 496155A2

Fusibles :

Les deux parties électriques doivent être raccordées en série avec un fusible de sécurité conformément à CEI 60127-3.

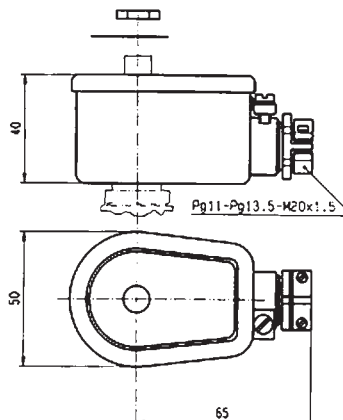



483270 ET 483270.02 - PARTIES ÉLECTRIQUES 50 mm

Ces bobines peuvent être montées avec toutes les électrovannes Parker ATEX correspondant au groupe électrique spécifique.

Voir la colonne "Groupe électrique" sur les pages concernant les vannes.

Application : contrôle des électrovannes dans un endroit dangereux nécessitant une protection antidéflagration Ex db IIC T4 à T6.

Avantages : boîtier en fonte orientable 360 ° avec chambre de connexion interne : couvercle en alliage d'aluminium fixé à l'aide de 4 vis. La commande de pilotage électromagnétique est composée de trois éléments principaux : le boîtier, la bobine et le tube de plongeur incluant la plaque de boîtier.

Petite taille pour un montage facile dans les espaces confinés.



Référence		483270 (M20 x 1,5) 483270.02 (1/2 NPT)			
Certificat		LCIE 02 ATEX 6008 X			
Groupe électrique		11.0			
Type de protection	Gaz	II 2 G - Ex db IIC T4	II 2 G - Ex db IIC T5	II 2 G - Ex db IIC T6	
	Poussières	II 2 D - Ex tb IIIC - T130°C	II 2 D - Ex tb IIIC - T 95°C	II 2 D - Ex tb IIIC - T 80°C	
Indice de protection		IP66 avec presse-étoupe adapté			
Température ambiante		entre -40 et +80 °C	entre -40 °C et +75 °C	entre -40 °C et +60 °C	
Classe d'isolation		F (155 °)			
Raccordement électrique		Le raccordement électrique se fait dans la chambre de connexion interne sur une borne à vis accessible. L'entrée du câble vers la chambre de connexion se fait à travers le trou fileté NPT 1/2" adapté pour un presse-étoupe Ex db IIC approuvé.			
Alimentation électrique	CC	Pn (chaud)	8 W		
		P (froid) 20 °C	9 W		
	CA	Pn (maintien)	8 W		
		Attraction (froid)	9 W		
Poids		1100 g (avec bobine)			
Tensions "Un"		V CA/Hz	Code	V CC	Code
entre -10 % et +10 % de Un		24/50-60	P0	24	C2
		110-115/50-60	1P	48	C4
		220-230/50-60	3P	110	C5

Pour commander une bobine, choisissez la réf. bobine + le code tension, par exemple : 483270 pour 24 V CC = 483270C2

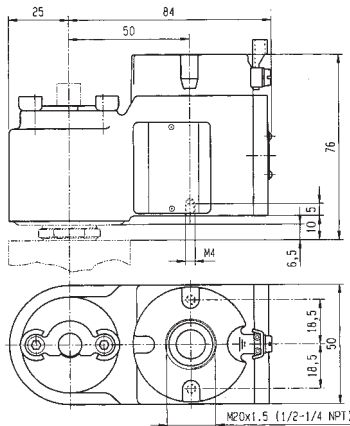

Tube de plongeur :

Le tube de plongeur est soudé sur une plaque en acier inoxydable et ainsi intégré dans le boîtier qui est vissé sur le corps de la vanne. Cette partie électrique est uniquement fournie en tant qu'unité complète montée sur une vanne, car la protection "Ex db" dépend du jeu minimum entre le tube de plongeur, la plaque et le boîtier.

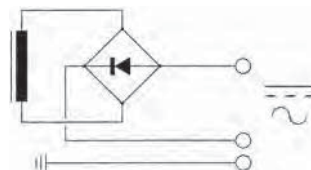

PARTIE ÉLECTRIQUE À FAIBLE PUISSANCE 22 mm

Ces bobines peuvent être montées avec toutes les électrovannes Parker ATEX correspondant au groupe électrique spécifique.

Voir la colonne "Groupe électrique" sur les pages concernant les vannes.

Application :

Contrôle des électrovannes dans un endroit dangereux nécessitant une protection antidéflagration Ex mb II T4 ou T5.

Avantages :

Bobine et circuit magnétique enrobés dans un matériau synthétique - Protection contre les chocs et la corrosion. Bobines CA avec fusible thermique intégré. Petite taille pour un montage facile dans les espaces confinés.



ZONE 1/21

Référence		482605		482606 ou 482606.160*			
Certificat		LCIE 02 ATEX 6014 X - IECEx LCI 07.0026 X					
Groupe électrique		1.1					
Type de protection	Gaz	II 2 G - Ex mb II T4		II 2 G - Ex mb II T4		II 2 G - Ex mb II T5	
	Poussières	II 2 D - Ex tb IIIC - T130°C		II 2 D - Ex tb IIIC - T130°C		II 2 D - Ex tb IIIC - T 95°C	
Indice de protection		IP65 (avec broche) selon CEI/EN 60529					
Température ambiante		entre -40 °C et +50 °C		entre -40 °C et +65 °C		entre -40 °C et +40 °C	
Classe d'isolation		F 155 °C					
Raccordement électrique		Raccordement de câble (3 x 0,75 mm ²) enroulé de bobine, matériau de câble selon l'application					
Alimentation électrique	CC	Pn (chaud)	5 W		2,5 W		
		P (froid) 20 °C	6,5 W		3 W		
	CA	Pn (maintien)	4 W		2 W		
		Attraction (froid)	8,9 VA (5 W)		5,7 VA (2,5 W)		
Poids		150 g					
Tensions "Un"		V CC	Code	V CA/Hz	Code	V CC	Code
entre -10 % et +10 % de Un		24	C2	24/50	A2	24	C2
		110	C5	48/50	A4	48	C4
				110/50-115/50	0A	110	C5
				220/50-230/50	3D		

Pour commander une bobine, choisissez la réf. bobine + le code tension, par exemple : 482605 pour 24 V CC = 482605C2

* 482606.160 - longueur de câble de 6 m

* 482606 - longueur de câble de 1.5 m

Fusibles :

Les deux parties électriques 482605 et 482606 doivent être raccordées en série avec un fusible de sécurité conformément à CEI 60127-3. Voir l'exemple ci-dessous :

482605 :

CC : 12 V, 1000 mA - 24 V, 500 mA - 48 V, 200 mA - 110 V, 100 mA
CA 50 HZ: 24 V, 500 mA - 48 V, 250 mA - 110/115 V, 100 mA - 220/230 V, 3 mA
CA 60 HZ: 24 V, 630 mA - 110/115 V, 125 mA - 220/230 V, 63 mA

482606 :

CC : 12 V, 400 mA - 24 V, 200 mA - 48 V, 100 mA - 110 V, 50 mA
AC 50 HZ: 24 V, 250 mA - 48 V, 125 mA - 110/115 V, 63 mA - 220/230 V, 32 mA
CA 60 HZ: 24 V, 315 mA - 110/115 V, 63 mA - 220/230 V, 32 mA

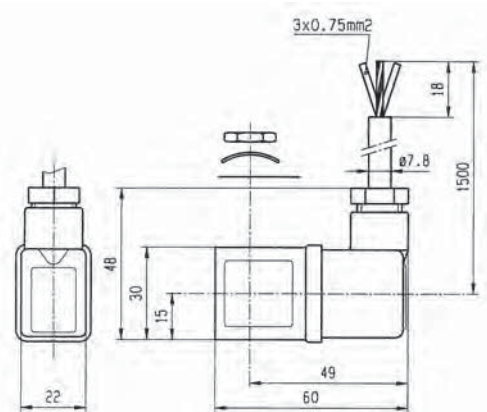

PARTIE ÉLECTRIQUE 32 mm

Cette bobine peut être montée avec toutes les électrovannes Parker ATEX correspondant au groupe électrique spécifique.
Voir la colonne "Groupe électrique" sur les pages concernant les vannes.

Application : contrôle des électrovannes dans un endroit dangereux nécessitant une protection antidéflagration Ex mb II T4.

Avantages : bobine et circuit magnétique enrobés dans un matériau synthétique permettant de fournir une protection contre les chocs et la corrosion. Bobines CA/CC avec fusible thermique intégré. Bobines CC avec diode intégrée contre les surtensions.

Petite taille pour un montage facile dans les espaces confinés.



Référence		492670 ou 492670.10* ou 492670.160**			
Certificat		LCIE 02 ATEX 6015 X			
Groupe électrique		2.0/2.1			
Type de protection	Gaz	II 2 G - Ex mb II T4			
	Poussières	II 2 D - Ex tb IIIC - T130°C			
Indice de protection		IP65 (avec connecteur à broches DIN) selon CEI 60529			
Température ambiante		entre -40 °C et +40 °C L'application est également limitée par la plage de température de la vanne.			
Classe d'isolation		F 155 °C			
Raccordement électrique		Raccordement de câble (3 x 1,5 mm ²) enroulé de bobine, matériau de câble selon l'application			
Alimentation électrique	CC	Pn (chaud)	9 W		
		P (froid) 20 °C	12 W		
	CA	Pn (maintien)	8 W		
		Attraction (froid)	26 VA (9 W)		
Poids		320 g			
Tensions "Un"		V CA/Hz	Code	V CC	Code
entre -10 % et +10 % de Un		48/50	A4	24	C2
		230/50	F4	48	C4
				110	C5

Pour commander une bobine, choisissez la réf. bobine + le code tension, par exemple : 492670 pour 24 V CC = 492670C2

* 492670.10 pour application en acier inoxydable - longueur de câble 3 m

** 492670.160 - longueur de câble de 6 m

Conditions spéciales :

Les câbles d'alimentation doivent être fixés et positionnés de sorte qu'ils soient protégés contre les dommages mécaniques.

Il est nécessaire d'utiliser un fusible de sécurité avec un courant nominal correspondant au courant de la bobine (au maximum 3 x la puissance nominale conformément à CEI 60127 et CEI 60269) contre les courts-circuits.

Valeurs recommandées :

CC : 12 V, 1250 mA - 24 V, 630 mA - 48 V, 315 mA - 110 V, 125 mA
CA 50 Hz : 24 V, 1000 mA - 48 V, 500 mA - 110 V, 250 mA - 230 V, 100 mA
CA 60 Hz : 240 V, 100 mA

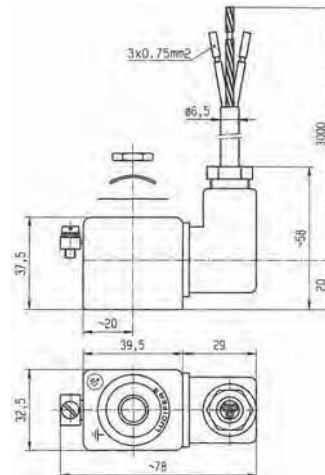

ZONE 1/21



AVEC BOÎTIER MÉTALLIQUE ÉTANCHE 50 mm

Ces bobines peuvent être montées avec toutes les électrovannes Parker ATEX correspondant au groupe électrique spécifique.

Voir la colonne "Groupe électrique" sur les pages concernant les vannes.

Application : contrôle des électrovannes dans un endroit dangereux nécessitant une protection antidéflagration Ex mb II T4 ou T5.

Avantages : boîtier en acier à revêtement époxy - Bobine de solénoïde, redresseur (diodes au silicium), fusible et élément de protection du varistor entièrement enrobés d'un boîtier de bobine en résine époxy.

Petite taille pour un montage facile dans les espaces confinés. Simplification du passage de l'équipement existant aux nouvelles exigences des lieux à risque.



ZONE 1/21

Référence	492070 492070.160 (avec une longueur de câble de 6 m)				
Certificat	LCIE 02 ATEX 6017 X - IECEx LCI 09.0024 X				
Groupe électrique	2.0/2.1				
Type de protection	Gaz	II 2 G - Ex mb II T4		II 2 G - Ex mb II T5	
	Poussières	II 2 D - Ex tb III C - T130 °C		II 2 D - Ex tb III C - T95 °C	
Température ambiante	entre -40 °C et +65 °C		entre -40 °C et +40 °C		
Classe d'isolation	F 155 °C				
Raccordement électrique	Raccordement de câble (3 x 1,5 mm ²) avec presse-étoupe M20 x 1,5, raccordement avec vis externes pour une mise à la terre.				
Alimentation électrique	CC	Pn (chaud)	8 W		
		P (froid) 20 °C	10 W		
	CA	Pn (maintien)	9 W		
		Attraction (froid)	11 W		
Poids	500 g				
Tensions "Un"	V CA/Hz	Code	V CC	Code	
entre -10 % et +10 % de Un	24/50-60	P0	24	C2	
	110/50-60	P2	48	C4	
	220/50-60	R5	110	C5	
	230/50-60	P9			
	240/50-60	Q1			

Pour commander une bobine, choisissez la réf. bobine + le code tension, par exemple : 492070 pour 24 V CC = 492070C2

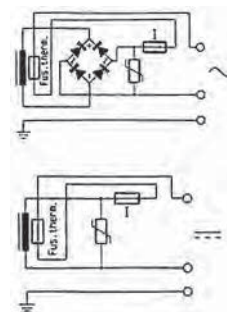
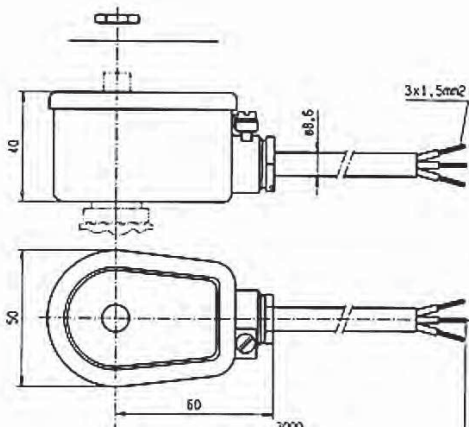

BOBINE À DOUBLE FRÉQUENCE HZ10

Cette bobine peut être montée avec toutes les électrovannes Parker ATEX correspondant au groupe électrique spécifique.
Voir la colonne "Groupe électrique" sur les pages concernant les vannes.

Application : contrôle des électrovannes dans un endroit dangereux nécessitant une protection antidéflagration Ex mb II T4 ou T5.



Caractéristiques		Double fréquence			
Référence		HZ10			
Certificat		LCIE 02 ATEX 6020 X - IECEx LCI 08.0027 X			
Groupe électrique		2.0/2.1			
Type de protection	Gaz	II 2 G - Ex mb II T4/T5			
	Poussières	II 2 D - Ex tb IIIC T			
Indice de protection		IP65 (avec broche) selon CEI/EN 60529			
Température ambiante		entre -40 °C et +65 °C L'application est également limitée par la plage de température de la vanne.			
Classe d'isolation		H 180 °C			
Cycle de fonctionnement		fonctionnement continu à 100%			
Raccordement électrique		Raccordement de câble (3 x 1,5 mm ²) avec presse-étoupe M20 x 1,5, raccordement avec vis externes pour une mise à la terre.			
Alimentation électrique	CC	Pn (chaud)	8 W		
		P (froid) 20 °C	-		
	CA	Pn (maintien)	8 W		
		Attraction (froid)	-		
Poids		299 g			
Tensions "Un"		V CA/Hz	Code	V CC	Code
entre -10 % et +10 % de Un		24	C2	110/50	A5
		110	C5	220/50	A7

Pour commander une bobine, choisissez la réf. bobine + le code tension, par exemple : HZ10 pour 24 V CC = HZ10C2

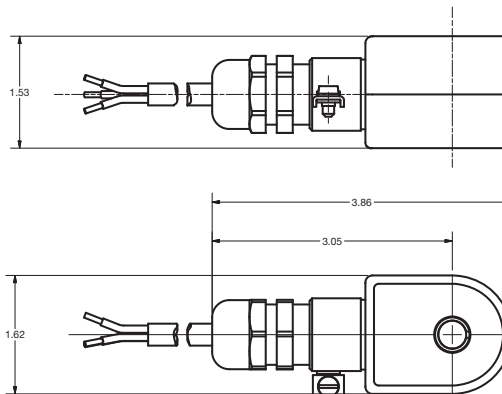

Dimensions en pouces.

BOBINE À DOUBLE FRÉQUENCE HZ11

Cette bobine peut être montée avec toutes les électrovannes Parker ATEX correspondant au groupe électrique spécifique.

Voir la colonne "Groupe électrique" sur les pages concernant les vannes.

Application : contrôle des électrovannes dans un endroit dangereux nécessitant une protection antidéflagration Ex mb II T4 ou T5.



Caractéristiques		Double fréquence			
Référence		HZ11			
Certificat		LCIE 02 ATEX 6020 X - IECEx LCI 08.0027 X			
Groupe électrique		2.0/2.2			
Type de protection	Gaz	II 2 G - Ex mb II T4/T5			
	Poussières	II 2 D - Ex tb IIIC T			
Indice de protection		IP65 (avec broche) selon CEI/EN 60529			
Température ambiante		entre -40 °C et +50 °C L'application est également limitée par la plage de température de la vanne.			
Classe d'isolation		H 180 °C			
Cycle de fonctionnement		fonctionnement continu à 100%			
Alimentation électrique	CC	Pn (chaud)	14 W		
		P (froid) 20 °C	-		
	CA	Pn (maintien)	14 W		
		Attraction (froid)	-		
Poids		299 g			
Tensions "Un"		V CA/Hz	Code	V CC	Code
entre -10 % et +10 % de Un		110/50 220/50	A5 A7	24 V	C2

Pour commander une bobine : réf. bobine + code tension, par exemple : HZ11 pour 24 V CC = HZ11C2

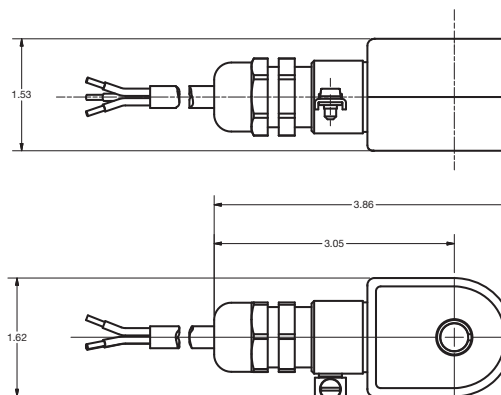

Dimensions en pouces.

6.0

PARTIES ÉLECTRIQUES
ENROBÉES RÉSISTANTES
AUX FLAMMES "db mb"



495900 - PARTIES ÉLECTRIQUES À FAIBLE PUISSANCE 37 mm

Cette bobine peut être montée avec toutes les électrovannes Parker ATEX correspondant au groupe électrique spécifique. Voir la colonne "Groupe électrique" sur les pages concernant les vannes.

Application : contrôle des électrovannes dans un endroit dangereux nécessitant une protection antidéflagration Ex db IIC T4 à T6.

Avantages : boîtier en plastique renforcé par des fibres de verre orientable 360 ° (classe H). Bobine de solénoïde, redresseur (diodes au silicium), fusibles et protection du varistor entièrement enrobés dans le boîtier de bobine en résine époxy pour une protection contre les chocs et la corrosion.

Le boîtier en plastique est livré avec un presse-étoupe M20 x 1,5 certifié pour la protection "db". Petite taille pour un montage facile dans les espaces confinés.



Référence		495900			
Certificat		LCIE 03 ATEX 6451 X - IECEx LCI 06.0004 X			
Groupe électrique		6.0			
Type de protection	Gaz	II 2 G - Ex db mb IIC T4 / T5 / T6		II 2 G - Ex db mb IIC T5 / T6	
	Poussières	II 2 D Ex tb IIIC - 130°C / 95°C / 80°C		II 2 D Ex tb IIIC - 95°C / 80°C	
Indice de protection		IP67			
Température ambiante		entre -40 °C et +80 °C/+55 °C/+40 °C		entre -40 °C et +80 °C/+55 °C	
Classe d'isolation		L'application est également limitée par la plage de température de la vanne. H (180 °)			
Raccordement électrique		Le raccordement électrique se fait dans le boîtier de raccordement sur une borne de connecteur facilement accessible. L'introduction de câble (Ø 5 mm mini., Ø 11 mm maxi., section 2,5 mm² maxi.) dans le boîtier de raccordement passe par le presse-étoupe M20 x 1,5 intégré.			
Alimentation électrique	CC	Pn (chaud)	-	2 W	
		P (froid) 20 °C	-	2,5 W	
	CA	Pn (maintien)	2,5 W	-	
		Attraction (froid)	3 W	-	
Tensions "Un"		V CA/Hz	Code	V CC	Code
entre -10 % et +10 % de Un		24/50	A2	24	C2
pour CA		48/50	A4	48	C4
entre -10 % et +10 % de Un		115/50	E5	110	C5
pour CC.		230/50	F4		

Pour commander une bobine : réf. bobine + code tension, par exemple : 495900 pour 24 V CC = 495900C2

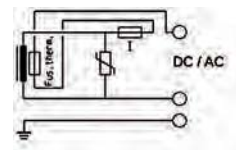
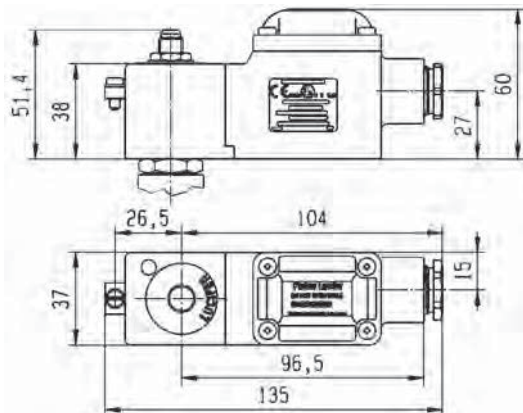



495905 - PARTIES ÉLECTRIQUES 37 mm

Ces bobines peuvent être montées avec toutes les électrovannes Parker ATEX correspondant au groupe électrique spécifique.

Voir la colonne "Groupe électrique" sur les pages concernant les vannes.

Application : contrôle des électrovannes dans un endroit dangereux nécessitant une protection antidéflagration Ex db mb IIC T4.

Avantages : boîtier en plastique renforcé par des fibres de verre orientable 360 ° (classe H). Bobine de solénoïde, redresseur (diodes au silicium), fusibles et protection du varistor entièrement enrobés dans le boîtier de bobine en résine époxy pour une protection contre les chocs et la corrosion.

Le boîtier en plastique est livré avec un presse-étoupe M20 x 1,5 certifié pour la protection "db". Petite taille pour un montage facile dans les espaces confinés.



ZONE 1/21

Référence		495905	495905.05		
Certificat		LCIE 03 ATEX 6451 X - IECEx LCI 06.0004 X			
Groupe électrique		2.0/2.1			
Type de protection	Gaz	II 2 G - Ex db mb IIC T4			
	Poussières	II 2 D - Ex tb IIIC - 130 °C			
Indice de protection		IP67			
Température ambiante		entre -40 °C et +80 °C L'application est également limitée par la plage de température de la vanne.			
Classe d'isolation		H (180 °)			
Raccordement électrique		Le raccordement électrique se fait dans le boîtier de raccordement sur une borne de connecteur facilement accessible. L'introduction de câble (Ø 5 mm mini., Ø 11 mm maxi., section 2,5 mm² maxi.) dans le boîtier de raccordement passe par le presse-étoupe M20 x 1,5 intégré.			
Alimentation électrique	CC	Pn (chaud)	8 W		
		P (froid) 20 °C	9 W		
	CA	Pn (maintien)	8 W		
		Attraction (froid)	9 W		
Tensions "Un"		V CA/Hz	Code	V CC	Code
entre -10 % et +10 % de Un pour CA entre -10 % et +10 % de Un pour CC.		24/50	A2	24	C2
		48/50	A4	48	C4
		115/50	E5	110	C5
		230/50	F4		

Pour commander une bobine, choisissez la réf. bobine + le code tension, par exemple : 495905 pour 24 V CC = 495905C2

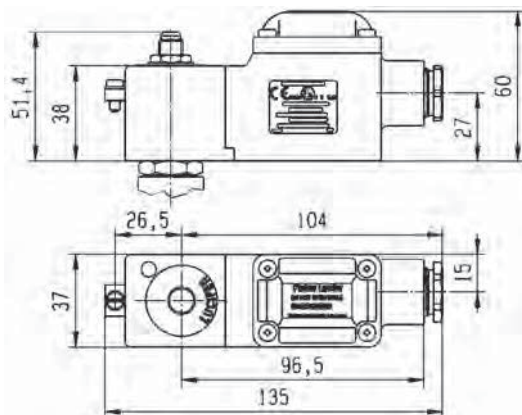

495905

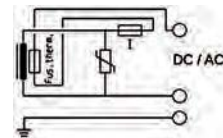

*495905.05

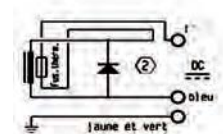

PARTIES ÉLECTRIQUES
ENROBÉES RÉSISTANTES
AUX FLAMMES "db mb"



496555 ET 496560 - PARTIES ÉLECTRIQUES 37 mm

Ces bobines peuvent être montées avec toutes les électrovannes Parker ATEX correspondant au groupe électrique spécifique.

Voir la colonne "Groupe électrique" sur les pages concernant les vannes.

Application : contrôle des électrovannes dans un endroit dangereux nécessitant une protection antidéflagration Ex db mb IIC T4 à T6.

Avantages : boîtier en plastique renforcé par des fibres de verre orientable 360 ° (classe H). Bobine de solénoïde, redresseur (diodes au silicium), fusibles et protection du varistor entièrement enrobés dans le boîtier de bobine en résine époxy pour une protection contre les chocs et la corrosion.

Le boîtier en plastique est livré avec un presse-étoupe M20 x 1,5 certifié pour la protection "db". Petite taille pour un montage facile dans les espaces confinés.



Référence		496555				496560			
Certificat		LCIE 07 ATEX 6075 X - IECEx LCI 07.0014X							
Groupe électrique		10.2				10.1			
Type de protection	Gaz	II 2 G - Ex db mb IIC T4 / T5 / T6				II 2 G - Ex db mb IIC T4			
	Poussières	II 2 D - Ex tb IIIC - T130 / 95 / 80°C				II 2 D - Ex tb IIIC - T130°C			
Indice de protection		IP 67							
Température ambiante		entre -40 °C et +65 °C L'application est également limitée par la plage de température de la vanne.							
Classe d'isolation		H (180 °)							
Raccordement électrique		Le raccordement électrique se fait dans le boîtier de raccordement sur une borne de connecteur facilement accessible. L'introduction de câble (Ø 5 mm mini., Ø 11 mm maxi., section 2,5 mm² maxi.) dans le boîtier de raccordement passe par le presse-étoupe M20 x 1,5 intégré.							
Alimentation électrique	CC	Pn (chaud)	-	6 W	-	8 W			
		P (froid) 20 °C	-	7,5 W	-	10,5 W			
	CA	Pn (maintien)	6 W	-	8 W				
		Attraction (froid)	7,5 W	-	10,5 W				
Tensions "Un"		V CA/Hz	Code	V CC	Code	V CA/Hz	Code	V CC	Code
entre -10 % et +10 % de Un		230/50-60	P9	24	C2	230/50-60	P9	24	C2
		110/50-60	P2	48	C4	110/50-60	P2	48	C4
		24/50-60	P0	110	C5	24/50-60	P0	110	C5
		48/50-60	S4			48/50-60	S4		

Pour commander une bobine, choisissez la réf. bobine + le code tension, par exemple : 496555 pour 24 V CC = 495865C2

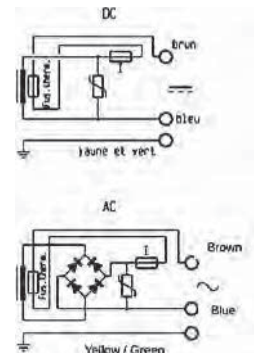
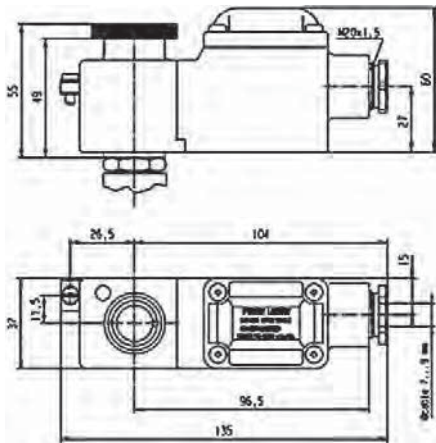

PARTIE ÉLECTRIQUES
ENROBÉES RÉSISTANTES
AUX FLAMMES "db mb"



496700 ET 496800 - PARTIES ÉLECTRIQUES 37 mm

Ces bobines peuvent être montées avec toutes les électrovannes Parker ATEX correspondant au groupe électrique spécifique.

Voir la colonne "Groupe électrique" sur les pages concernant les vannes.

Application : contrôle des électrovannes dans un endroit dangereux nécessitant une protection antidéflagration Ex db mb IIC T4 à T6.

Avantages : boîtier en plastique renforcé par des fibres de verre orientable 360 ° (classe H). Bobine de solénoïde, redresseur (diodes au silicium), fusibles et protection du varistor entièrement enrobés dans le boîtier de bobine en résine époxy pour une protection contre les chocs et la corrosion.

Le boîtier en plastique est livré avec un trou fileté 1/2" ou M20 x 1,5 pour une large gamme des presse-étoupes. Petite taille pour un montage facile dans les espaces confinés.



ZONE 1/21

Référence		496700				496800			
Certificat		LCIE 07 ATEX 6075 X - IECEx LCI 07.0014X							
Groupe électrique		10.2				10.1			
Type de protection	Gaz	II 2 G - Ex db mb IIC T4 / T5 / T6				II 2 G - Ex db mb IIC T4			
	Poussières	II 2 D - Ex tb IIIC - T130 / 95 / 80°C				II 2 D - Ex tb IIIC - T130°C			
Indice de protection		IP67							
Température ambiante		entre -40 °C et +35 °C/+50 °C/+65 °C				entre -40 °C et +65 °C			
Classe d'isolation		H (180°)							
Raccordement électrique		Le raccordement électrique se fait dans le boîtier de raccordement sur une borne de connecteur facilement accessible. L'introduction de câble (Ø 5 mm mini., Ø 11 mm maxi., section 2,5 mm² maxi.) dans le boîtier de raccordement passe dans un filetage NPT 1/2 ou M20 x 1,5 avec presse-étoupe certifié Ex dBIC.							
Alimentation électrique	CC	Pn (chaud)	-	6 W	-	-	8 W	-	-
		P (froid) 20 °C	-	7,5 W	-	-	10,5 W	-	-
	CA	Pn (maintien)	6 W	-	-	8 W	-	-	-
		Attraction (froid)	7,5 W	-	-	10,5 W	-	-	-
Tensions "Un"		V CA/Hz	Code	V CC	Code	V CA/Hz	Code	V CC	Code
entre -10 % et +10 % de Un		230/50-60	P9	24	C2	230/50-60	P9	24	C2
		110/50-60	P2	48	C4	110/50-60	P2	48	C4
		24/50-60	P0	110	C5	24/50-60	P0	110	C5
		48/50-60	S4	-	-	48/50-60	S4	-	-

Pour commander une bobine, choisissez la réf. bobine + le code tension, par exemple : 496700 pour 24 V CC = 496700C2

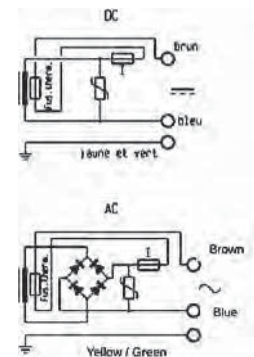
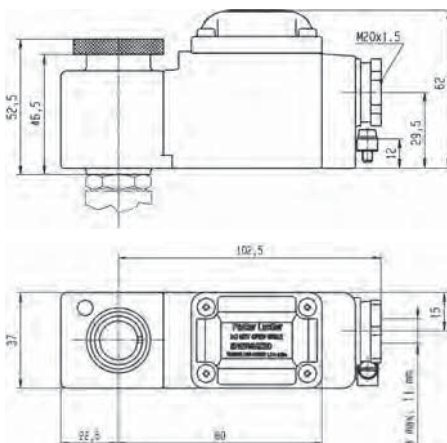



493640 OU HZ09 - PARTIES ÉLECTRIQUES

Cette bobine peut être montée avec toutes les électrovannes Parker ATEX correspondant au groupe électrique spécifique.

Voir la colonne "Groupe électrique" sur les pages concernant les vannes.

Application : contrôle des électrovannes dans un endroit dangereux nécessitant une protection Ex db mb II 2 G/D T4 à T5.

Avantages : l'armature métallique enrobée dans un matériau synthétique permettant de fournir une protection contre les chocs et la corrosion.

Petite taille pour un montage facile dans les espaces confinés.



Référence		493640 ou HZ09 493640.60* ou HZ55			
Certificat		LCIE 02 ATEX 6009 X			
Groupe électrique		2.0/2.1			
Type de protection		II 2 G - Ex db mb T4/T5			
Gaz		II 2 D - Ex tb IIIC - T130°C / T95°C			
Poussières		IP65			
Indice de protection		entre -40 °C et +75 °C/+40 °C L'application est également limitée par la plage de température de la vanne.			
Température ambiante		F (155 °)			
Classe d'isolation		Presses-étoupe "Ex db" spécial, acier trempé, avec joint EPDM. Câble (EPR), diamètre extérieur de 7,3 ± 0,5 mm et longueur de 3000 mm.			
Raccordement électrique					
Alimentation électrique	CC	Pn (chaud)	8 W		
		P (froid) 20 °C	9 W		
	CA	Pn (maintien)	8 W		
		Attraction (froid)	32 VA (9 W)		
Poids		500 g			
Tensions "Un"		V CA/Hz	Code	V CC	Code
entre -15 % et +10 % de Un		110/50	A5	24	C2
		110-120/50-60	P3	48	C4
		220-240/50-60	Q3	120	C6

Pour commander une bobine, choisissez la réf. bobine + le code tension, par exemple : 493640 pour 24 V CC = 493640C2

* 493640.60 - longueur de câble de 6 m

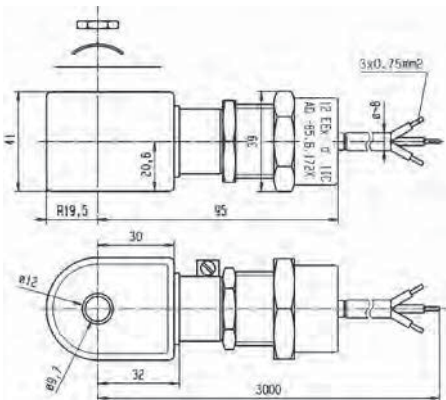

Fusibles

Cette partie électrique est équipée d'un fusible thermique standard sur tous les modèles et tensions.

Cette partie électrique doit être connectée en série avec un fusible de sécurité conformément à CEI 60127-3.

- CC : 24 V, 400 mA
- CA : 110/50-120/60, 200 mA
- 220/50-240/60, 100 mA
- 230/50, 95 mA

ZONE 1/21



483371 ET 494040 - PARTIES ÉLECTRIQUES 50 mm

Cette bobine peut être montée avec toutes les électrovannes Parker ATEX correspondant au groupe électrique spécifique.

Voir la colonne "Groupe électrique" sur les pages concernant les vannes.

Application : contrôle des électrovannes dans un endroit dangereux nécessitant une protection antidéflagration Ex e mb, e II T3 ou T4.

Avantages : boîtier orientable 360°, acier trempé avec bornes à vis internes et externes pour une mise à la terre.

Petite taille pour un montage facile dans les espaces confinés. Simplification du passage de l'équipement existant aux nouvelles exigences des lieux à risque.



ZONE 1/21

Référence		483371				494040				
Certificat		LCIE 02 ATEX 6011 X				LCIE 02 ATEX 6013 X				
Groupe électrique		2.0/2.1								
Type de protection	Gaz	II 2 G - Ex e mb IIC T4 Gb				II 2 G - Ex e IIC T3 / T4 Gb				
	Poussières	II 2 D - Ex tb IIIC - T130°C Db				II 2 D - Ex tb IIIC - T195°C / T130 °C Db				
Indice de protection		IP67								
Température ambiante		entre -40 °C et +65 °C L'application est également limitée par la plage de température de la vanne.				entre -40 °C et +90 °C/+65 °C				
Classe d'isolation		F 155 °C				F (180 °)				
Raccordement électrique		Par presse-étoupe spécial ou M20 x 1,5 "Ex eb" sur les bornes à vis pour les fils jusqu'à 1,5 mm ² . Les câbles ayant un diamètre extérieur allant de 6,5 mm à 13,5 mm peuvent simplement être scellés en utilisant un presse-étoupe en caoutchouc avec les bagues d'étanchéité élastiques fournies.								
Alimentation électrique	CC	Pn (chaud)	8 W				8 W			
		P (froid) 20 °C	9 W				9 W			
	CA	Pn (maintien)	8 W				8 W			
		Attraction (froid)	32 VA (9 W)				32 VA (9 W)			
Poids		320 g								
Tensions "Un"		V CA/Hz	Code	V CC	Code	V CA/Hz	Code	V CC	Code	
entre -10 % et +10 % de Un		24/50	A2	24	C2	220-230/50	3D	24	C2	
		48/50	A4	48	C4					
		110-115/50	0A	110	C5					
		220-230/50	3D							

Pour commander une bobine, choisissez la réf. bobine + le code tension, par exemple : 483371 pour 24 V CC = 483371C2

Fusibles :

Les deux parties électriques doivent être raccordées en série avec un fusible de sécurité conformément à CEI 60127-3.

483371 :

CC : 24 V, 400 mA - 48 V, 250 mA - 110 V, 100 mA

CA 50 HZ : 24 V, 630 mA - 48 V, 315 mA - 110 V, 160 mA - 220/230 V, 80 mA

494040 :

CC : 12 V, 400 mA - 24 V, 200 mA - 48 V, 100 mA - 110 V, 50 mA

CA 50 HZ : 24 V, 250 mA - 48 V, 125 mA - 110/115 V, 63 mA - 220/230 V, 32 mA

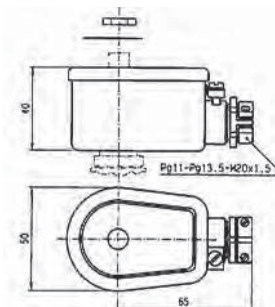

492310 - PARTIES ÉLECTRIQUES 50 mm

Cette bobine peut être montée avec toutes les électrovannes Parker ATEX correspondant au groupe électrique spécifique.

Voir la colonne "Groupe électrique" sur les pages concernant les vannes.

Application : contrôle des électrovannes dans un endroit dangereux nécessitant une protection antidéflagration Ex eb mb II T4 à T5.

Avantages : boîtier en plastique renforcé par des fibres de verre orientable 360 °. Bobine de solénoïde, redresseur (diodes au silicium), fusibles et protection du varistor entièrement enrobés dans le boîtier de bobine en résine époxy pour une protection contre les chocs et la corrosion.

Petite taille pour un montage facile dans les espaces confinés.



Référence		492310			
Certificat		LCIE 02 ATEX 6023 X - IECEx LCI 06.0011 X			
Groupe électrique		10.1			
Type de protection	Gaz	II 2 G - Ex eb mb II T4/T5			
	Poussières	II 2 D - Ex tb IIIC - T130°C / T95°C			
Indice de protection		IP66			
Température ambiante		entre -40 °C et +75 °C/+40 °C La durée de fonctionnement de la vanne/la bobine peut être limitée par la vanne.			
Classe d'isolation		F 155 °C			
Raccordement électrique		Boîtier de raccordement avec bornes et entrée des câbles via le presse-étoupe M20 x 1,5 - Possibilité d'une mise à la terre supplémentaire via une vis externe.			
Alimentation électrique	CC	Pn (chaud)	6 W		
		P (froid) 20 °C	7,5 W		
	CA	Pn (maintien)	6 W		
		Attraction (froid)	7,5 W		
Poids		500 g			
Tensions "Un"		V CA/Hz	Code	V CC	Code
entre -10 % et +10 % de Un		24/50-60	P0	24	C2
		48/50-60	S4	48	C4
		230/50-60	P9	110	C5

Pour commander une bobine, choisissez la réf. bobine + le code tension, par exemple : 492310 pour 24 V CC = 492310C2

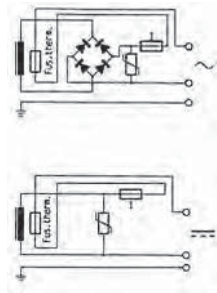
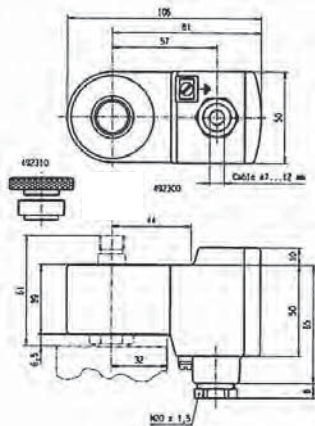

ZONE 1/21



492210 - PARTIES ÉLECTRIQUES "BOOSTER" 50 mm

Ces bobines peuvent être montées avec toutes les électrovannes Parker ATEX correspondant au groupe électrique spécifique.

Voir la colonne "Groupe électrique" sur les pages concernant les vannes.

Application : contrôle des électrovannes dans un endroit dangereux nécessitant une protection antidéflagration - Ex eb mb IIC T5/T6.

Avantages : boîtier orientable 360 °, acier trempé avec bornes à vis internes et externes pour une mise à la terre.

Petite taille pour un montage facile dans les espaces confinés. Simplification du passage de l'équipement existant aux nouvelles exigences des lieux à risque.



Référence	492210
Certificat	LCIE 02 ATEX 6023 X - IECEx LCI 06.0011 X
Groupe électrique	9.0
Type de protection	Gaz II 2 G - Ex eb mb IIC T5 / T6
	Poussières II 2 D - Ex tb IIIC - T95°C / T80°C
Indice de protection	IP66
Température ambiante	entre -40 °C et +75 °C/+40 °C La durée de fonctionnement de la vanne/la bobine peut être limitée par la vanne.
Classe d'isolation	F 155 °C
Raccordement électrique	Boîtier de raccordement avec bornes et entrée des câbles via le presse-étoupe M20 x 1,5 Possibilité d'une mise à la terre supplémentaire via une vis externe
Consommation électrique CC	de 1 à 1,8 W en fonction de la longueur du câble
Courant d'attraction	I min = 60 mA (I nominal = 75 mA)
Tension CC	U nominal = 24 V CC (C2), Umin = 21,6 V CC
Résistance	23 Ω + (R = 270 Ω)
Inductance	0 mH
Capacité	0 μF
Temps de réaction	2 à 4 s
Poids	500 g

Pour commander une bobine, choisissez la réf. bobine + le code tension, par exemple : 492210 pour 24 V CC = 492210C2

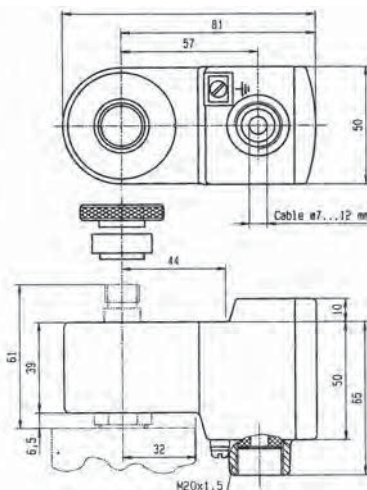

Indications :

Survoleur pour les vannes offshore

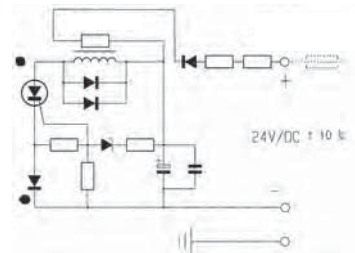

Ces parties électriques nécessitent un fusible externe d'I = 100 mA

492190 - PARTIES ÉLECTRIQUES 50 mm

Cette bobine peut être montée avec toutes les électrovannes Parker ATEX correspondant au groupe électrique spécifique.

Voir la colonne "Groupe électrique" sur les pages concernant les vannes.

Application : contrôle des électrovannes dans un endroit dangereux nécessitant une protection antidéflagration Ex eb mb IIC T3 à T4.

Avantages : boîtier en plastique renforcé par des fibres de verre orientable 360 °. Bobine de solénoïde, redresseur (diodes au silicium), fusibles et protection du varistor entièrement enrobés dans le boîtier de bobine en résine époxy pour une protection contre les chocs et la corrosion.

Petite taille pour un montage facile dans les espaces confinés.



Référence		492190			
Certificat		LCIE 02 ATEX 6023 X - IECEx LCI 06.0011 X			
Groupe électrique		2.0/2.1			
Type de protection	Gaz	II 2 G - Ex eb mb IIC T3 / T4			
	Poussières	II 2 D - Ex tb IIC - 195°C / 130°C			
Indice de protection		IP66			
Température ambiante		entre -40 °C et +75 °C/+40 °C La durée de fonctionnement de la vanne/la bobine peut être limitée par la vanne.			
Classe d'isolation		F 155 °C			
Raccordement électrique		Boîtier de raccordement avec bornes et entrée des câbles via le presse-étoupe M20 x 1,5 Possibilité d'une mise à la terre supplémentaire via une vis externe			
Consommation électrique	CC	Pn (chaud)	9 W		
		P (froid) 20 °C	11 W		
	CA	Pn (maintien)	11 W		
		Attraction (froid)	13 W		
Poids		320 g			
Tensions "Un"		V CA/Hz	Code	V CC	Code
entre -10 % et +10 % de Un		24/50-60	P0	24	C2
		110/50-60	P2	48	C4
		230/50-60	P9	110	C5

Pour commander une bobine, choisissez la réf. bobine + le code tension, par exemple : 492190 pour 24 V CC = 492190C2

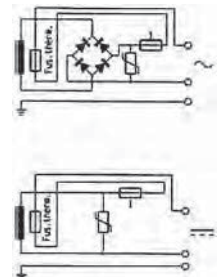
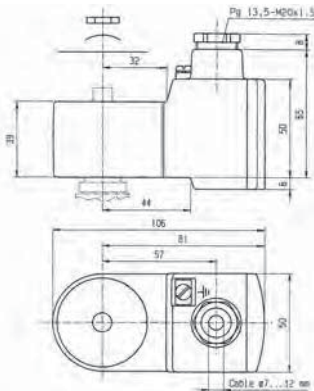

ZONE 1/21



483580 - PARTIES ÉLECTRIQUES 32 mm "IS"

Ces bobines peuvent être montées avec toutes les électrovannes Parker ATEX correspondant au groupe électrique spécifique.

Voir la colonne "Groupe électrique" sur les pages concernant les vannes.

Application : contrôle des électrovannes dans un endroit dangereux nécessitant une protection antidéflagration Ex ia IIC T6.

Avantages : ensemble entièrement enrobé comprenant une bobine, une armature métallique, un circuit à trois diodes et un connecteur à broches DIN.

L'enrobage permet de protéger l'ensemble compact contre la pénétration de corps étrangers (ex. : poussière, huile, eau, etc).

Petite taille pour un montage facile dans les espaces confinés.



Référence (sans broche) (avec broche)		483580.01 ou DZ12 483960.01 ou DZ13
Certificat		LCIE 02 ATEX 6065 X - IECEx LCI 07.0025 X
Groupe électrique		7.0
Type de protection	Gaz	II 1 G - Ex ia IIC - T6
	Poussières	II 1 D - Ex tD A20 - T80 °C
Indice de protection		IP65 avec broche
Température ambiante		entre -40 °C et +55 °C La durée de fonctionnement de la vanne/la bobine peut être limitée par la vanne.
Classe d'isolation		F 155 °C
Raccordement électrique		La bobine est raccordée à l'aide d'une broche 2 P + T selon EN 175301-803, type A. Le contact 1 est le pôle positif, indiqué par ⊕.
Tension d'alimentation maximum		28 V CC (N7) - 110 mA La tension de fonctionnement minimum à 60 °C maxi. est de 14 V CC.
Puissance	CC Minimum	500 mW
	Maximum	3 W
		En fonction de la tension appliquée, type de barrière IS et résistance du câble connecté
Résistance de la bobine à 20 °C		340 Ω
Impédance		340 Ω
Inductance apparente		0 mH
Capacité apparente		0 μF
Poids		160 g (avec broche)

Pour commander une bobine, choisissez la réf. bobine + le code tension, par exemple : 483580 pour 28 V CC = 483580N7

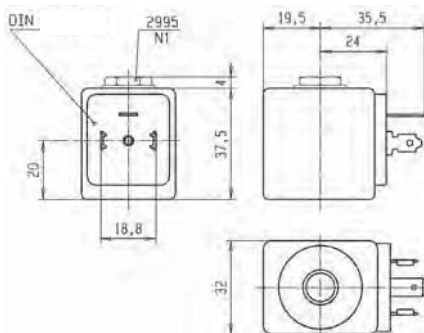

Important

Le circuit d'alimentation à sécurité intrinsèque doit avoir suffisamment de capacité dans toutes les conditions environnementales pour assurer un **courant de fonctionnement minimal de 35 mA** à travers la bobine.

Le courant de maintien minimal est de 20 mA.

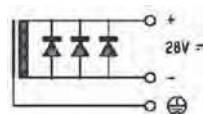

Pour la compatibilité des barrières, voir le tableau correspondant dans l'annexe.

**495910 - MINIWATT - 0,3 W
PARTIES ÉLECTRIQUES "IS0" "BOOSTER" 37 mm**

Ces bobines peuvent être montées avec toutes les électrovannes Parker ATEX correspondant au groupe électrique spécifique.

Voir la colonne "Groupe électrique" sur les pages concernant les vannes.

Application : contrôle des électrovannes dans un endroit dangereux nécessitant une protection antidéflagration Ex ia IIC T4 à T6.

Avantages : boîtier en plastique renforcé par des fibres de verre orientable 360 ° (classe H). Bobine de solénoïde, redresseur (diodes au silicium), fusibles et protection du varistor entièrement enrobés dans le boîtier de bobine en résine époxy pour une protection contre les chocs et la corrosion.

Le boîtier en plastique est livré avec un presse-étoupe M20 x 1,5. Petite taille pour un montage facile dans les espaces confinés.



Référence		495910	495910.02 (Presse-étoupe bleu)
Certificat		LCIE 03 ATEX 6464 X - IECEx LCI 07.0006 X	
Groupe électrique		8.0	
Type de protection	Gaz	II 1 G - Ex ia IIB - T6 T5 T4	
	Poussières	II 1 D - Ex tD A20 - T80 T95 T130 °C	
Indice de protection		IP67	
Température ambiante		entre -40 °C et +65 °C/+75 °C/+80 °C L'application est également limitée par la plage de température de la vanne.	
Raccordement électrique		Le raccordement électrique se fait dans le boîtier de raccordement sur une borne de connecteur facilement accessible. L'introduction de câble (Ø 7 mm mini., Ø 11 mm maxi., section 2,5 mm² maxi.) dans le boîtier de raccordement passe par le presse-étoupe M20 x 1,5 intégré.	
Tension d'alimentation maximum		28 V CC (N7) - 110 mA	28 V CC (N7) - 280 mA
Puis- sance CC	Minimum	0,3 W (avec 13 V CC)	0,3 W (avec 13 V CC)
	Maximum	1,2 W (avec 24 V CC)	2,58 W (avec 24 V CC)
		En fonction de la tension appliquée, type de barrière IS et résistance du câble connecté	
Vérification de ligne		4 mA ou 5 V CC maxi.	
Résistance de la bobine à 20 °C		Charge environ 550 Ω - Maintien environ 500 Ω	
Impédance		0 mH	
Inductance apparente		0 µF	
Capacité apparente		0 µF	
Temps de réaction		2 à 3 s	
Poids		500 g	

Pour commander une bobine, choisissez la réf. bobine + le code tension, par exemple : 495910 pour 28 V CC = 495910N7

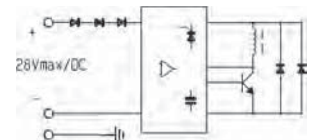
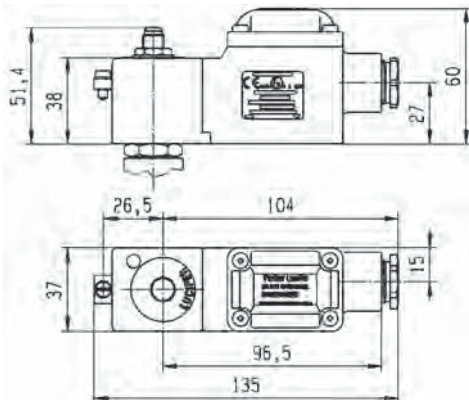



496565 PARTIES ÉLECTRIQUES "BOOSTER" "IS" 37 mm

Cette bobine peut être montée avec toutes les électrovannes Parker ATEX correspondant au groupe électrique spécifique.

Voir la colonne "Groupe électrique" sur les pages concernant les vannes.

Application : contrôle des électrovannes dans un endroit dangereux nécessitant une protection antidéflagration Ex ia IIC T4 à T6.

Avantages : boîtier en plastique renforcé par des fibres de verre orientable 360 ° (classe H).

Bobine de solénoïde, redresseur (diodes au silicium), fusibles et protection du varistor entièrement enrobés dans le boîtier de bobine en résine époxy pour une protection contre les chocs et la corrosion.

Le boîtier en plastique est livré avec un presse-étoupe M20 x 1,5. Petite taille pour un montage facile dans les espaces confinés.



Référence	496565	
Certificat	LCIE 08 ATEX 6071 X - IECEx LCI 08.0030 X	
Groupe électrique	9.0	
Type de protection	Gaz	II 1 G - Ex ia IIC - T6/T5/T4
	Poussières	II 1 D - Ex ta IIC - T80/T95 T130 °C
Indice de protection	IP67	
Température ambiante	entre -40 °C et +65 °C/+75 °C/+80 °C L'application peut également être limitée par la plage de température de la vanne.	
Raccordement électrique	Raccordement de câble via un presse-étoupe M20 x 1,5 en plastique permettant l'utilisation d'un diamètre de câble entre 7 et 12 mm. Possibilité d'une mise à la terre supplémentaire avec une borne à vis externe.	
Courant minimal de fonctionnement	20 mA	
Tension minimale de fonctionnement à 60 °C	28 V CC (N7)	
Paramètres de sécurité Valeurs maximales acceptables : Ui (V)/Ii (mA)/Pi (W)	28 V/110 mA/0,77 W	28 V/280 mA/1,96 W
	27 V/120 mA/0,81 W	27 V/320 mA/2,16 W
	26 V/135 mA/0,88 W	26 V/350 mA/2,27 W
	25 V/150 mA/0,94 W	25 V/390 mA/2,43 W
	24 V/170 mA/1,02 W	24 V/430 mA/2,58 W
Vérification de ligne	4 mA ou 5 V CC maxi.	
Type d'impédance apparente.	Attraction environ 600 Ω - Maintien environ 570 Ω	
Inductance apparente	0 mH	
Capacité apparente	0 µF	
Type de temps de réponse.	2 à 4 s	
Poids	500 g	

Pour commander une bobine, choisissez la réf. bobine + le code tension,
par exemple : 496565 pour 13 V CC = 496565N7

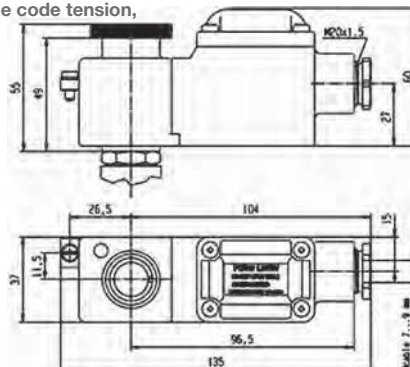

ZONE 0/20

492965 PARTIES ÉLECTRIQUES "BOOSTER" "IS" 50 mm

Cette bobine peut être montée avec toutes les électrovannes Parker ATEX correspondant au groupe électrique spécifique.

Voir la colonne "Groupe électrique" sur les pages concernant les vannes.

Application : contrôle des électrovannes dans un endroit dangereux nécessitant une protection antidéflagration Ex ia ou ib IIC T6.

Avantages : boîtier orientable 360°, boîtier et couvercle métalliques revêtus d'époxy. La bobine, les circuits électroniques et les autres éléments nécessaires pour une sécurité intrinsèque sont entièrement enrobés dans un matériau époxy pour une protection contre les chocs et la corrosion.

Petite taille pour un montage facile dans les espaces confinés.



Référence	492965.01 - Fixation en acier inoxydable	
Certificat	LCIE 02 ATEX 6066 X - IECEx LCI 07.0007 X	
Groupe électrique	9.0	
Type de protection	Gaz	II 1 G - Ex ia IIC - T6
	Poussières	II 1 D - Ex ta IIC - T80 °C
Indice de protection	IP66	
Température ambiante	entre -40 °C et +65 °C L'application est également limitée par la plage de température de la vanne.	
Raccordement électrique	Raccordement de câble via un presse-étoupe M20 x 1,5 en plastique ou en acier inoxydable permettant l'utilisation d'un diamètre de câble entre 10 et 12 mm. Possibilité d'une mise à la terre supplémentaire avec une borne à vis externe.	
Tension d'alimentation maximum	28 V CC (N7) - 110 mA	
Puissance	CC	Minimum
		Maximum
		0,3 W (avec 13 V CC)
		2,3 W (avec 24 V CC)
	En fonction de la tension appliquée, type de barrière IS et résistance du câble connecté	
Vérification de ligne	4 mA ou 5 V CC maxi.	
Résistance de la bobine à 20 °C	85 Ω	
Impédance	275 Ω (avec 13 V CC) - 260 Ω (avec 24 V CC)	
Inductance apparente	0 mH	
Capacité apparente	0 μF	
Temps de réaction	2 à 4 s	
Poids	500 g	

Pour commander une bobine, choisissez la réf. bobine + le code tension, par exemple : 492965.01 pour 28 V CC = 492965.01N7

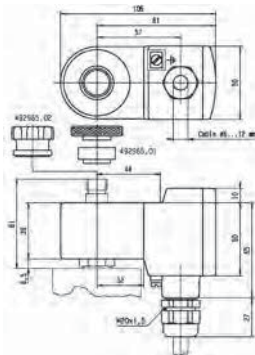

Important

Le circuit d'alimentation à sécurité intrinsèque doit avoir suffisamment de capacité dans toutes les conditions environnementales pour assurer un **courant de fonctionnement minimal de 29 mA** à travers la bobine.

Le courant de maintien minimal est de 20 mA.

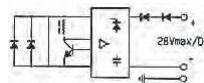

Pour la compatibilité des barrières, voir le tableau correspondant dans l'annexe.

**482870.01 ET 492335 PARTIES ÉLECTRIQUES
"NEMA" "IS" 50 mm**

Ces bobines peuvent être montées avec toutes les électrovannes Parker ATEX correspondant au groupe électrique spécifique.

Voir la colonne "Groupe électrique" sur les pages concernant les vannes.

Application : contrôle des électrovannes dans un endroit dangereux nécessitant une protection antidéflagration Ex ia IIC ou IIB T6.

Avantages: boîtier orientable 360°, en polyamide avec boîtier et couvercle en fibres de verre. La bobine, les circuits électroniques et les autres éléments nécessaires pour une sécurité intrinsèque sont entièrement enrobés dans un matériau époxy pour une protection contre les chocs et la corrosion.

Petite taille pour un montage facile dans les espaces confinés.



ZONE 0/20

Référence		482870.01	492335
Certificat		LCIE 02 ATEX 6024 X	LCIE - FM - CSA
Groupe électrique		12.0	
Type de protection	Gaz	II 1 G - Ex ia IIC - T6	Cl. I, Div. I, Gr. A, B, C, D
	Poussières	II 1 D - Ex ta IIC - T80 °C	Cl. II, Div. I, Gr. E, F, G
Indice de protection		IP66	NEMA 4 - 4X
Température ambiante		entre - 40 °C et +65 °C L'application est également limitée par la plage de température de la vanne.	+60 °C
Raccordement électrique Raccordement de câble via un presse-étoupe M20 x 1,5 en acier inoxydable permettant l'utilisation d'un diamètre de câble entre 10 et 12 mm. Possibilité d'une mise à la terre supplémentaire avec une borne à vis externe.			
Tension d'alimentation maximum		28 V CC (N7) - 280 mA	30 V CC (N7) - 100 mA
Puis- sance CC	Minimum	300 mW	
	Maximum	3 W	
En fonction de la tension appliquée, type de barrière IS et résistance du câble connecté			
Résistance de la bobine à 20 °C		295 Ω	
Impédance		345 Ω	
Inductance apparente		0 mH	
Capacité apparente		0 µF	
Poids		500 g	

Pour commander une bobine, choisissez la réf. bobine + le code tension, par exemple : 492335 pour 30 V CC = 492335N7

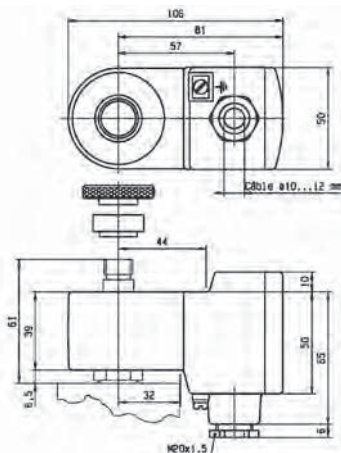
**Important**

Le circuit d'alimentation à sécurité intrinsèque doit avoir suffisamment de capacité dans toutes les conditions ambiantes pour assurer un courant de fonctionnement minimal supérieur à **29 mA** à travers la bobine.

Le courant minimal pour le maintien en position alimentée est de 20 mA.

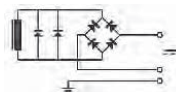

Pour la compatibilité des barrières, voir le tableau correspondant dans l'annexe.

488650.01 ET 490885 PARTIES ÉLECTRIQUES
"NEMA" "IS" 50 mm

Cette bobine peut être montée avec toutes les électrovannes Parker ATEX correspondant au groupe électrique spécifique.

Voir la colonne "Groupe électrique" sur les pages concernant les vannes.

Application : contrôle des électrovannes dans un endroit dangereux nécessitant une protection antidéflagration Ex ia ou ib IIC T6.

Avantages : boîtier orientable 360°, en polyamide avec boîtier et couvercle en fibres de verre. La bobine, les circuits électroniques et les autres éléments nécessaires pour une sécurité intrinsèque sont entièrement enrobés dans un matériau époxy pour une protection contre les chocs et la corrosion.

Petite taille pour un montage facile dans les espaces confinés.



Référence		488650.01	490885
Certificat		LCIE 02 ATEX 6024 X	LCIE/FM/CSA
Groupe électrique		7.0	
Type de protection	Gaz	II 1 G - Ex ia IIC - T6	Cl. I, Div.I, Gr. A, B, C, D
	Poussières	II 1 D - Ex ta IIIC - T80 °C	Cl. II, Div.I, Gr. E, F, G
Indice de protection		IP66	NEMA 4 - 4X
Température ambiante		entre - 40 °C et +65 °C La durée de fonctionnement de la vanne/la bobine peut être limitée par la vanne.	60 °C
Raccordement électrique		Entrée de câble via un presse-étoupe M20 x 1,5. Bornes à vis 3 câbles de 1,5 mm ² maxi. Possibilité d'une mise à la terre supplémentaire avec une borne à vis externe	
Tension d'alimentation maximum		28 V CC (N7) - 110 mA La tension de fonctionnement minimum à 60 °C maxi. est de 11,5 V CC.	30 V CC (N7) - 110 mA
Puissance CC	Minimum	300 mW	
	Maximum	3 W	
		En fonction de la tension appliquée, type de barrière IS et résistance du câble connecté	
Résistance de la bobine à 20 °C		295 Ω	
Impédance		345 Ω	
Inductance apparente		0 mH	
Capacité apparente		0 μF	
Poids		500 g	

Pour commander une bobine, choisissez la réf. bobine + le code tension, par exemple : 490885 pour 30 V CC = 490885N7

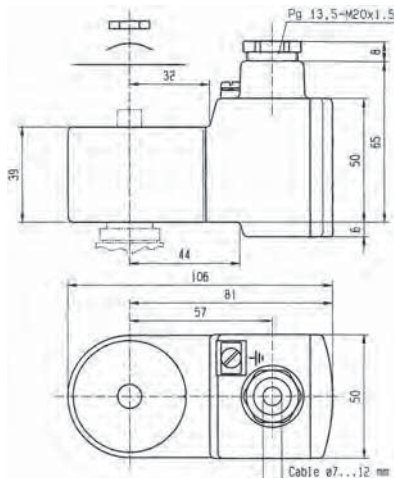

Important

Le circuit d'alimentation à sécurité intrinsèque doit avoir suffisamment de capacité dans toutes les conditions environnementales pour assurer un **courant de fonctionnement minimal de 29 mA** à travers la bobine. Le courant de maintien minimal est de 20 mA.

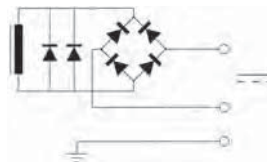

Pour la compatibilité des barrières, voir le tableau correspondant dans l'annexe.



488660.01 ET 490890 PARTIES ÉLECTRIQUES "NEMA" "IS" 50 mm

Ces bobines peuvent être montées avec toutes les électrovannes Parker ATEX correspondant au groupe électrique spécifique.

Voir la colonne "Groupe électrique" sur les pages concernant les vannes.

Application : contrôle des électrovannes dans un endroit dangereux nécessitant une protection antidéflagration Ex ia ou ib IIC T6.

Avantages : boîtier orientable 360 °, boîtier et couvercle métalliques revêtus d'époxy. La bobine, les circuits électroniques et les autres éléments nécessaires pour une sécurité intrinsèque sont entièrement enrobés dans un matériau époxy pour une protection contre les chocs et la corrosion.

Petite taille pour un montage facile dans les espaces confinés.



ZONE 0/20

Référence		488660.01	490890
Certificat		LCIE 02 ATEX 6024 X	LCIE/FM/CSA
Groupe électrique		7.0	
Type de protection	Gaz	II 1 G - Ex ia IIC - T6	Cl. I, Div.1, Gr. A, B, C, D
	Poussières	II 1 D - Ex ta IIIC - T80 °C	Cl. II, Div.1, Gr. E, F, G
Indice de protection		IP67	NEMA 4 - 4X
Température ambiante		entre - 40 °C et +65 °C	+60 °C
		La durée de fonctionnement de la vanne/la bobine peut être limitée par la vanne.	
Raccordement électrique		Entrée de câble via un presse-étoupe M20 x 1,5. Bornes à vis 3 câbles de 1,5 mm ² maxi. Possibilité d'une mise à la terre supplémentaire avec une borne à vis externe.	
Tension d'alimentation maximum		28 V CC - 110 mA (N7)	30 V CC - 100 mA (N7)
		La tension de fonctionnement minimum à 60 °C maxi. est de 11,5 V CC.	
Puissance	CC Minimum	300 mW	
	Maximum	3 W	
		En fonction de la tension appliquée, type de barrière IS et résistance du câble connecté	
Résistance de la bobine à 20 °C		295 Ω	
Impédance		345 Ω	
Inductance apparente		0 mH	
Capacité apparente		0 μF	
Poids		500 g	

Pour commander une bobine, choisissez la réf. bobine + le code tension, par exemple : 490890 pour 30 V CC = 490890N7

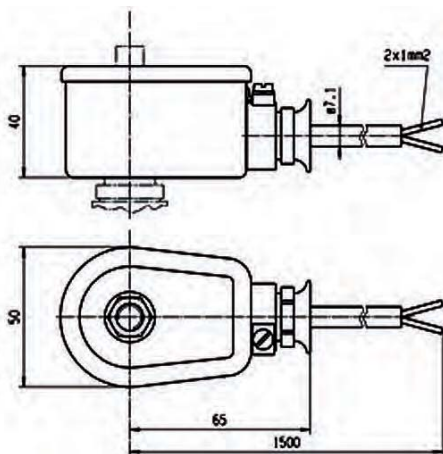

Important

Le circuit d'alimentation à sécurité intrinsèque doit avoir suffisamment de capacité dans toutes les conditions ambiantes pour assurer un courant de fonctionnement minimal supérieur à 29 mA à travers la bobine.

Le courant minimal pour le maintien en position alimentée est de 20 mA.

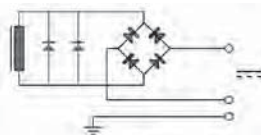

Pour la compatibilité des barrières, voir le tableau correspondant dans l'annexe.

488670.01 - PARTIES ÉLECTRIQUES "IS" 50 mm

Cette bobine peut être montée avec toutes les électrovannes Parker ATEX correspondant au groupe électrique spécifique.

Voir la colonne "Groupe électrique" sur les pages concernant les vannes.

Application : contrôle des électrovannes dans un endroit dangereux nécessitant une protection antidéflagration Ex ia ou ib IIC T6.

Avantages : boîtier orientable 360°, boîtier et couvercle métalliques revêtus d'époxy. La bobine, les circuits électroniques et les autres éléments nécessaires pour une sécurité intrinsèque sont entièrement enrobés dans un matériau époxy pour une protection contre les chocs et la corrosion.

Petite taille pour un montage facile dans les espaces confinés.



Référence		488670.01	
Certificat		LCIE 02 ATEX 6024 X	
Groupe électrique		7.0	
Type de protection	Gaz	II 1 G - Ex ia IIC - T6	
	Poussières	II 1 D - Ex ta IIIC - T80 °C	
Indice de protection		IP65	
Température ambiante		entre -40 °C et +65 °C La durée de fonctionnement de la vanne/la bobine peut être limitée par la vanne.	
Raccordement électrique		Entrée de câble via un presse-étoupe M20 x 1,5. Bornes à vis 3 câbles de 1,5 mm ² maxi. Possibilité d'une mise à la terre supplémentaire avec une borne à vis externe.	
Tension d'alimentation maximum		28 V CC (N7) - 110 mA La tension de fonctionnement minimum à 60 °C maxi. est de 11,5 V CC.	
Puis- sance	CC	Minimum	300 mW
		Maximum	3 W
En fonction de la tension appliquée, type de barrière SI et résistance du câble connecté			
Résistance de la bobine à 20 °C		295 Ω	
Impédance		345 Ω	
Inductance apparente		0 mH	
Capacité apparente		0 μF	
Poids		500 g	

Pour commander une bobine, choisissez la réf. bobine + le code tension, par exemple : 488670.01 pour 28 V CC = 488670.01N7

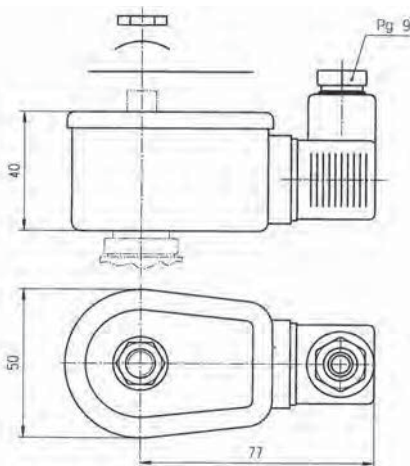

Important

Le circuit d'alimentation à sécurité intrinsèque doit avoir suffisamment de capacité dans toutes les conditions ambiantes pour assurer un courant de fonctionnement minimal supérieur à 29 mA à travers la bobine.

Le courant minimal pour le maintien en position alimentée est de 20 mA.

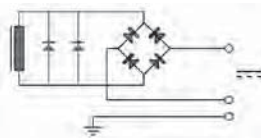

Pour la compatibilité des barrières, voir le tableau correspondant dans l'annexe.

SOMMAIRE

INTRODUCTION

Index par référence de bobine.....	446
Index par groupe électrique.....	448
Index pour les parties électriques antidéflagrantes.....	450
Liste des groupes électrique.....	451

BOBINES

Bobines pour connecteur à broches DIN.....	454
Bobines avec câbles volants.....	477
Bobines avec bornes à vis.....	482
Bobines avec connecteur ISO-DIN.....	488

PARTIES ÉLECTRIQUES ANTIDÉFLAGRANTES

Niveau de protection "nc AC".....	490
Niveau de protection "db".....	498
Niveau de protection "mb".....	499
Niveau de protection "db mb".....	504
Niveau de protection "eb".....	509
Niveau de protection "ia".....	513

BOÎTIERS.....	522
----------------------	------------

ACCESSOIRES DE BOBINE.....	526
-----------------------------------	------------

ENVIRONNEMENTS EXPLOSIFS.....	528
--------------------------------------	------------

ANNEXES POUR BOBINES

Tableau informatif pour les barrières IS.....	538
Tableau des codes tension pour les bobines et les parties électriques.....	540

BOÎTIER POUR BOBINE STANDARD
AVEC BORNES À VIS

Boîtier standard :

Référence :	4270
Matériau :	Acier à revêtement époxy avec traitement par électrophorèse
Indice de protection :	IP conformément à la norme CEI/EN 60529 IP 10 avec conduit armé IP 44 avec presse-étoupe
Raccordement électrique :	possible avec conduit armé ou presse-étoupe M12 x 1,5. Parties n° 484092 et 484093 à commander séparément. Raccordement à la terre à l'aide d'une vis M3 à l'intérieur de la plaque du boîtier.
Poids :	120 g



Avantages :

Ce boîtier en métal offre la protection idéale contre les chocs et la corrosion. Il est orientable 360°, facile à installer dans les espaces confinés, montable à l'aide d'un seul écrou, très léger et simplifie la conversion des équipements existants pour répondre à d'autres exigences.

Application :

La plupart des vannes Lucifer® peuvent être équipées de ce boîtier standard et installées avec plusieurs groupes électrique Lucifer® compatibles.

Bobines compatibles :

- **481000 - Bobine standard**
8 W Classe F (155 °C)
- **483520 - Bobine à double fréquence**
9 W Classe F (155 °C)
- **481044 - Bobine standard haute puissance**
14 W Classe F (155 °C)
- **485100 - Bobine standard haute température**
8 W Classe H (180 °C)
- **486265 - Bobine haute température et haute puissance**
14 W Classe H (180 °C)

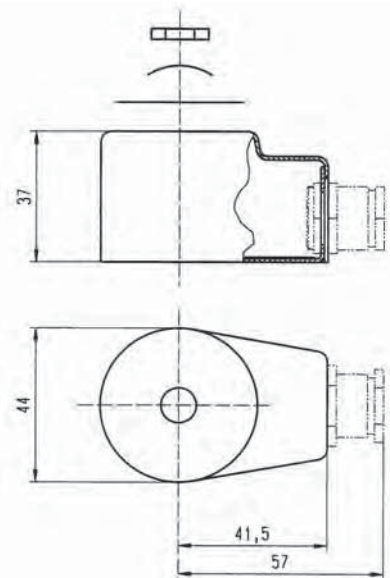

BOÎTIER

4269**BOÎTIER POUR DES BOBINES BISTABLES
(À IMPULSION)****Boîtier pour bobine bistable :**

Référence :	4269
Matériau :	acier à revêtement époxy
Indice de protection :	IP conformément à la norme CEI/EN 60529 IP 10 avec conduit armé IP 44 avec presse-étoupe
Raccordement électrique :	possible avec conduit armé ou presse-étoupe M12 x 1,5. Parties n° 484092 et 484093 à commander séparément. Raccordement à la terre à l'aide d'une vis M3 à l'intérieur de la plaque du boîtier.
Poids :	120 g

**Avantages :**

Ce boîtier en métal offre la protection idéale contre les chocs et la corrosion. Il est orientable 360°, facile à installer dans les espaces confinés, montable à l'aide d'un seul écrou, très léger et simplifie la conversion des équipements existants pour répondre à d'autres exigences.

Application :

Le boîtier est spécialement conçu pour les bobines du groupe 706 et ne peut être installé qu'avec des vannes à impulsion électrique.

Bobines compatibles :

- **484990 - Bobine à impulsion pour CA**
11 W Classe F (155 °C)
- **485400 - Bobine à impulsion pour CC**
13 W Classe F (155 °C)

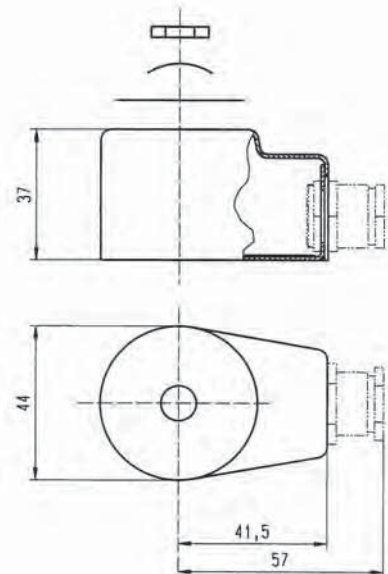

BOÎTIER ÉTANCHE À L'EAU ET À LA POUSSIÈRE

Boîtier étanche à l'eau :

Référence :	4538
Matériau :	Acier passivé galvanisé
Indice de protection :	IP conformément à la norme CEI/EN 60529 IP 67 avec presse-étoupe
Raccordement électrique :	Raccordement de câble via un presse-étoupe M12 x 1,5 conformément à DIN 46320. Les câbles ayant un diamètre extérieur allant de 6,5 mm à 13,5 mm peuvent simplement être scellés en utilisant un presse-étoupe en caoutchouc avec des bagues d'étanchéité élastiques. Le boîtier est à l'intérieur et à l'extérieur équipé de bornes à vis de mise à la terre.
Poids :	180 g



Avantages :

Ce boîtier est étanche à la poussière et à l'eau. Il correspond à la "protection internationale" conformément à la norme CEI/EN 60529. Le boîtier en métal est résistant à la corrosion et offre une bonne protection de la bobine contre les chocs et autres influences extérieures. Il offre les avantages suivants : orientable 360°, montage facile dans les espaces confinés, accès facile aux bornes à vis, montage à l'aide d'un seul écrou, poids faible, conversion simple des équipements existants pour répondre à d'autres exigences sans interruption de la circulation du fluide dans la vanne.

Application :

Le boîtier peut être équipé de plusieurs bobines de notre gamme comme les bobines standard, à double fréquence et à verrouillage magnétique.

Bobines compatibles :

- **481000 - Bobine standard**
8 W Classe F (155 °C)
- **483520 - Bobine à double fréquence**
9 W Classe F (155 °C)
- **484990 - Bobine à impulsion pour CA**
11 W Classe F (155 °C)
- **485400 - Bobine à impulsion pour CC**
13 W Classe H (180 °C)

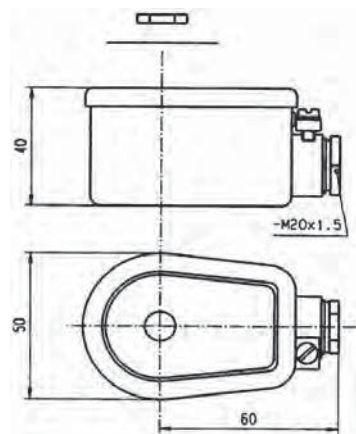

BOÎTIER

8520**BOÎTIER ÉTANCHE À L'EAU
POUR DES BOBINES HAUTE TEMPÉRATURE**

Boîtier étanche à l'eau :

Référence :	8520
Matériau :	Acier passivé galvanisé
Indice de protection :	IP conformément à la norme CEI/EN 60529 IP 67 avec presse-étoupe
Raccordement électrique :	Raccordement de câble via un presse-étoupe M12 x 1,5 conformément aux normes européennes. Les câbles ayant un diamètre extérieur allant de 6,5 mm à 13,5 mm peuvent simplement être scellés en utilisant un presse-étoupe en caoutchouc avec des bagues d'étanchéité élastiques. Le boîtier est à l'intérieur et à l'extérieur équipé de bornes à vis de mise à la terre.
Poids :	180 g

**Avantages :**

Ce boîtier est étanche à la poussière et à l'eau. Il correspond à la "protection internationale" conformément à la norme CEI/EN 60529. Le boîtier en métal est résistant à la corrosion et offre une bonne protection de la bobine contre les chocs et autres influences extérieures. Il offre les avantages suivants : orientable 360°, montage facile dans les espaces confinés, accès facile aux bornes à vis, montage à l'aide d'un seul écrou, poids faible, conversion simple des équipements existants pour répondre à d'autres exigences sans interruption de la circulation du fluide dans la vanne.

Application :

La plupart des vannes Lucifer® peuvent être équipées de ce boîtier standard et installées avec plusieurs bobines Lucifer® pour haute température compatibles (14 W, 8 W Classe F ou H).

Bobines compatibles :

- **481044 - Bobine haute puissance**
14 W Classe F (155 °C)
- **486265 - Bobine haute puissance**
14 W Classe H (180 °C)
- **485100 - Bobine haute température**
8 W Classe H (180 °)

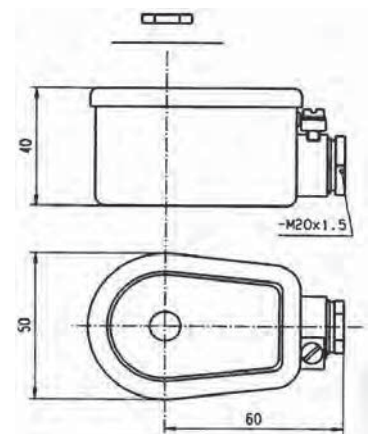

22 mm 32 mm

KITS D'ASSEMBLAGE DE LA BOBINE

KIT D'ASSEMBLAGE POUR UNE BOBINE DE 22 mm

Le kit d'assemblage de la bobine correspond au système de numérotation pour les boîtiers des vannes Lucifer® (vanne - boîtier - bobine - tension).

Il est composé d'une plaque signalétique avec des informations concernant le type de vanne, d'une rondelle et d'un écrou pour fixer la bobine de 22 mm sur la vanne.

Attention : ces kits d'assemblage pour bobines de 22 mm ne sont pas adaptés aux vannes haut débit. Renseignez-vous auprès de votre distributeur pour obtenir le kit adapté.



Référence	Caractéristiques	Application
8993	Standard - plaque signalétique en aluminium - rondelle et écrou passivés - pression en [bar]	Vannes standard
8993.03	Standard - Plaque signalétique en aluminium - Rondelle et écrou passivés - Indication de pression en [psi]	Vannes standard
8122	Spéciale - Plaque signalétique en aluminium - Rondelle et écrou en acier inoxydable - Indication de pression en [psi]	316L St. Vannes en acier
8567	Spéciale - Écrou moleté, plat, en aluminium	Vannes pour eau - Série 321K3...

KIT D'ASSEMBLAGE POUR UNE BOBINE DE 32 mm

Le kit d'assemblage de la bobine correspond au "boîtier" du système de numérotation des vannes Lucifer® (vanne - boîtier - bobine - tension).

Il est composé d'une plaque signalétique avec des informations concernant le type de vanne, d'une rondelle et d'un écrou pour assurer la fixation entre la bobine de 32 mm et la vanne.



Référence	Caractéristiques	Application
2995	Standard - Plaque signalétique en aluminium - Rondelle et écrou en acier passivé - Indication de pression en [bar]	Vannes standard
2995.03	Standard - Plaque signalétique en aluminium - Rondelle et écrou en acier passivé - Indication de pression en [psi]	Vannes UL/CSA
8132	Spéciale - Plaque signalétique en aluminium - Rondelle et écrou en acier inoxydable - Indication de pression en [psi]	Vannes 316L en acier inoxydable
2161	Spéciale - Plaque signalétique en aluminium - Rondelle et écrou en acier passivé - Indication de pression en [bar]	Vannes pour le transport
2168	Spéciale AD Bleu - Plaque signalétique en aluminium - Rondelle et écrou en acier passivé - Indication de pression en [bar]	Vannes pour le transport
2169	Spéciale AD Bleu - Plaque signalétique en aluminium - Rondelle et écrou en acier passivé - Indication de pression en [bar]	Vannes pour le transport

ACCESSOIRES

CONNECTEUR À BROCHES DIN SELON EN 175301-803 - B

N° 481043

Raccordement électrique adapté à toutes les bobines de 22 mm
(ex. : 488980, 481180)

**CONNECTEUR À BROCHES DIN SELON EN 175301-803 - A**

N° 486586 pour la version standard

N° 492645 pour la version à haute température

Raccordement électrique adapté à toutes les bobines de 32 mm
(ex. : 481865, 492425)

**KIT D'ASSEMBLAGE EN ACIER INOXYDABLE**

Écrou n° 482213 M14 x 1+ bague n° 482214 +
Joint torique n° 483917

Kit d'assemblage de la bobine pour les parties électriques offshore
(ex. : 482870.01, 483330.01, 492210, 492965.01, 496565, 496700)

**ÉCROU EN PLASTIQUE AVEC INSERT MÉTALLIQUE**

N° 8886

Parties électriques pour huile et gaz
(ex. : 492965.01, 492300,)

**PRESSE-ÉTOUPE**

N° 492398 - Pg 13.5 -Ex eb II

N° 493841 - M20x1.5 - Ex ia IIC

Raccordement électrique et câble d'amarrage avec un diamètre entre 6 et 12 mm,
pour parties électriques homologuées "eb mb" ou "ia"
(ex. : 492190, 492965....)

**PRESSE-ÉTOUPE**

N° 493426 - 1/2"-14 NPT

Raccordement électrique et câble d'amarrage avec un diamètre entre 6 et 12 mm,
pour parties électriques homologuées résistantes aux flammes
(ex. : 493640)





INTRODUCTION

Les réglementations européennes en vigueur relatives aux appareils électriques pour des environnements potentiellement explosifs sont basées sur les directives européennes facultatives et partielles qui nécessitent une modification régulière sous forme d'application ou d'adaptation de directives pour suivre les évolutions techniques.

Le texte européen de base dans ce domaine, la directive **76/117/EC**, qui autorise la libre circulation des marchandises dans l'Union européenne, fixe le cadre général pour les réglementations actuelles.

Les appareils électriques pour une utilisation dans des environnements potentiellement explosifs sont certifiés par un organisme gouvernemental lorsqu'ils sont conformes aux normes européennes (à partir de EN 60079-0) couvrant chaque type de protection (**db**, **ia**, **eb**, **m**, **p**, etc). Un tel équipement est ensuite émis avec un **certificat d'examen CE de type**, lui permettant de porter le marquage distinctif.

Ce marquage permet le commerce à l'intérieur et parfois même à l'extérieur de l'Union Européenne.

Même si ce marquage est très avantageux, il a présenté quelques inconvénients, comme un manque de flexibilité et l'absence d'un concept global pour la sécurité. Il a été complètement revu par la **nouvelle directive européenne 94/9/EC du 23 mars 1994**.

Le certificat d'examen de type CE pour les normes harmonisées obtenu conformément aux directives précédentes reste valide jusqu'au 30 juin 2003, mais sa validité couvre uniquement la conformité aux normes harmonisées spécifiées dans ces directives.

PAYS MEMBRES DE L'UNION EUROPÉENNE

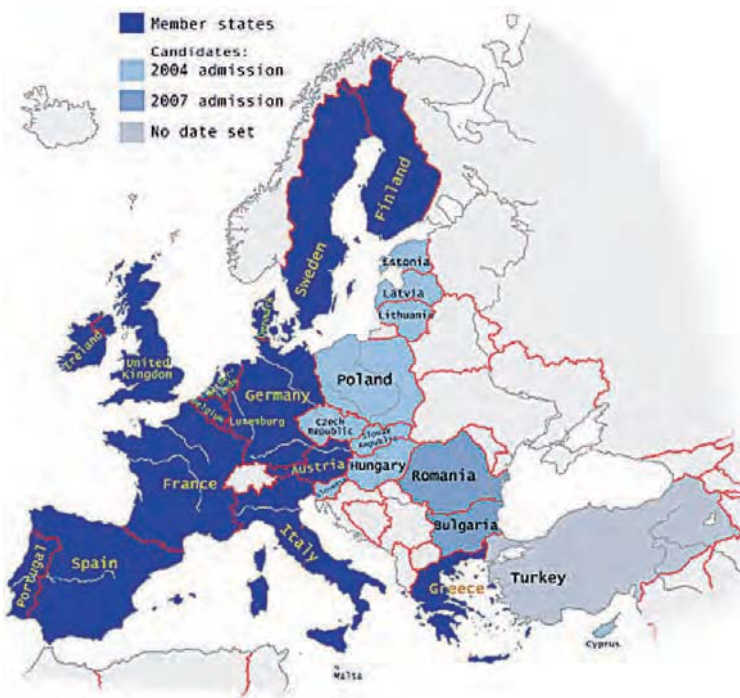



DÉFINITIONS

ENVIRONNEMENTS EXPLOSIFS

Mélange avec l'air, dans des conditions atmosphériques, de substances inflammables sous forme de gaz, vapeurs, brouillards ou poussières, dans lequel, après inflammation, la combustion se propage à l'ensemble du mélange non brûlé.

LIEUX À RISQUE

Un lieu à risque est un emplacement où une atmosphère explosive est présente ou peut se présenter en quantités telles que des précautions spéciales sont nécessaires pour la construction, l'installation et l'utilisation des appareils électriques.

INGRÉDIENTS POUR UNE EXPLOSION

Lorsque des matériaux combustibles se mélangent avec l'air, un mélange explosif se produit. Il existe donc un danger d'explosion partout où des matériaux dangereux sont manipulés : cette condition existe aussi bien dans la plus grande usine chimique que dans la plus petite station de service.

Aujourd'hui, avec l'utilisation des appareils électriques et électroniques dans le contrôle des processus, le risque d'inflammation dû à l'énergie électrique a fortement augmenté.

Pour protéger le personnel et les équipements coûteux, des précautions spéciales doivent être prises pour prévenir toute combustion de ces substances dangereuses. Conditions favorables à l'inflammation des mélanges explosifs :

- Lorsque des matériaux combustibles se mélangent avec l'air, un mélange explosif se produit. Il existe donc un danger d'explosion partout où des matériaux dangereux sont manipulés : cette condition existe aussi bien dans la plus grande usine chimique que dans la plus petite station de service.
- Aujourd'hui, avec l'utilisation des appareils électriques et électroniques dans le contrôle des processus, le risque d'inflammation dû à l'énergie électrique a fortement augmenté.
- Pour protéger le personnel et les équipements coûteux, des précautions spéciales doivent être prises pour prévenir toute combustion de ces substances dangereuses. Conditions favorables à l'inflammation des mélanges explosifs :

Il suffit de 3 facteurs pour entraîner une explosion

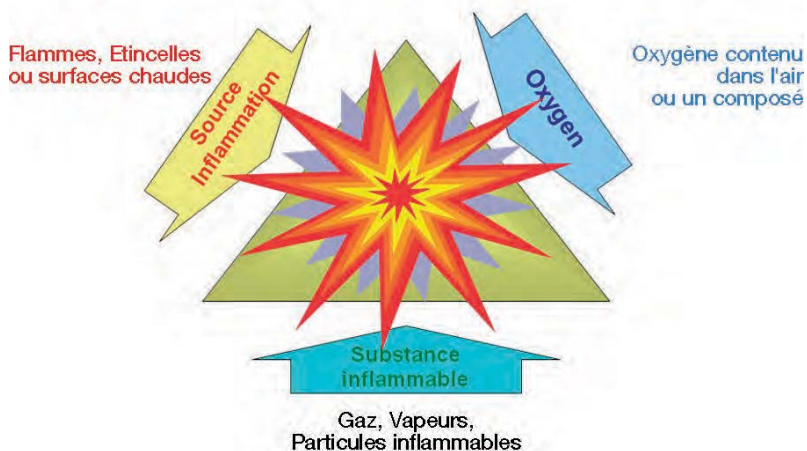



DÉFINITIONS

ZONES

Les lieux à risque sont classés selon la fréquence d'occurrence et la durée d'un environnement explosif comme suit :

Zone 0 (20)	Zone 1 (21)	Zone 2 (22)
Un endroit dans lequel une atmosphère de gaz explosif (ou de poussière explosive) est constamment présente pendant de longues périodes (environ 1000 h/an).	Un endroit dans lequel une atmosphère de gaz explosif (ou de poussière explosive) est susceptible d'être présente pendant le fonctionnement normal (environ 10 à 999 h/an).	Un endroit dans lequel une atmosphère de gaz explosif (ou de poussière explosive) est susceptible d'être présente pendant le fonctionnement normal (environ 1 à 10 h/an).
Mode de protection : ia - ma - px - ...	Mode de protection : db - eb - ib - mb - px - ...	Mode de protection : n - mc - ic - pz - ...

CLASSEMENT DES LIEUX À RISQUE

Environnement explosif	Présence continue	Présence intermittente (conditions de fonctionnement normales)	Présence occasionnelle (fonctionnement anormal)
CEI	Zone 0 (gaz) Zone 20 (poussière)	Zone 1 (gaz) Zone 21 (poussière)	Zone 2 (gaz) Zone 22 (poussière)
Europe	Zone 0 (gaz) Zone 20 (poussière)	Zone 1 (gaz) Zone 21 (poussière)	Zone 2 (gaz) Zone 22 (poussière)
Canada (CEC)¹ États-Unis (NEC)²	Cl. I Div. 1 (gaz) Cl. II Div. 1 (poussière) Cl. III Div. 1 (fibres)	Cl. I Div. 1 (gaz) Cl. II Div. 1 (poussière) Cl. III Div. 1 (fibres)	Cl. I Div. 2 (gaz) Cl. II Div. 2 (poussière) Cl. III Div. 2 (fibres)

¹ (CEC) : Code Canadien d'Électricité/² (NEC) : National Electrical Code

Exemple :

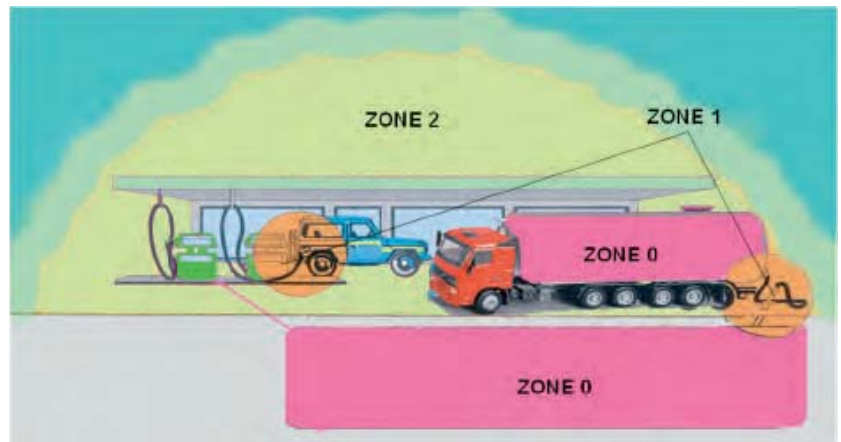



DÉFINITIONS

CLASSEMENT DES LIEUX À RISQUE

Catégorie	Protection contre les pannes	Atmosphère	Zone	Exemple de protections
-----------	------------------------------	------------	------	------------------------

Certificat d'examen CE délivré par un organisme notifié → annexe III

1 Niveau très élevé	2 types de protection ou 2 dysfonctionnements indépendants	G (Gaz)	0	"ia", "ma", "px" ou "ia-ma", "db/eb"
		D (Poussière)	20	

Certificat d'examen CE délivré par un organisme notifié → annexe III

2 Niveau élevé	Un type de protection Dysfonctionnement habituel et fréquent	G (Gaz)	1	Un type de protection lb, db, mb, eb, py, o, etc.
		D (Poussière)	21	

Contrôle de la production interne → Déclaration de conformité CE

3 Niveau normal	Niveau minimum de protection	G (Gaz)	2	n, ic, pz, ... A, C, L, P, R
		D (Poussière)	22	

Classement des lieux à risque

Groupe	Gaz
I	Méthane
IIA	Propane
IIB	Éthylène
IIC	Hydrogène/Acétylène

Classes des températures de surface

Classe de température	T° maxi.	°C	Gaz et température d'ignition	
T1	450°C	600	560°C Hydrogène	T1
T2	300°C	500	537°C Méthane	T1
T3	200°C	400	425°C Éthylène	T2
T4	135°C	300	305°C Acétylène	T2
T5	100°C	200	210°C Kérosène	T3
T6	85°C	100	160°C Éther éthylique	T4
		0	95°C Disulfure de carbone	T6



MODE DE PROTECTION UTILISÉ PAR PARKER LUCIFER®

MODES DE PROTECTION

Concept	Code		Zones	
	Gaz	Poussières	Gaz	Poussières
Enveloppe antidéflagrante	db	tb	1/2	21/22
Encapsulage	ma/mb/mc	tb/tc	0/1/2	20/21/22
Sécurité augmentée	eb	-	1/2	-
Sécurité intrinsèque	ia/ib/ic	ta/tb/tc	0/1/2	20/21/22
Appareil à surpression interne	px/py/pz	pD	1/2	21/22
Appareil de cat. 3	nA	-	2	-
	nL	-	2	-
	nR	-	2	-
	nC	-	2	-



NORMES ET TYPE DE PROTECTION

**MATÉRIEL ÉLECTRIQUE POUR LES ATMOSPHÈRES EXPLOSIVES
 GAZEUSES GROUPE II**

EPL	Normes EN/CEI	Protection	Nom
	60079-0	-	Règles générales
Ga	60079-11	ia	Sécurité intrinsèque
	60079-18	ma	Encapsulage
	60079-26		Matériel électrique de niveau de protection (EPL), Ga (Zone 0)
	60079-28	op is	Protection du matériel et des systèmes de transmission utilisant le rayonnement optique
Gb	60079-1	db	Enveloppes antidéflagrantes
	60079-2	p, px, py	Enveloppes à surpression interne
	60079-5	q	Remplissage pulvérulent
	60079-6	o	Immersion dans l'huile
	60079-7	eb	Sécurité augmentée
	60079-11	ib	Sécurité intrinsèque
	60079-18	mb	Encapsulage
	60079-25		Systèmes de sécurité intrinsèque
	60079-27		Concept de réseau de terrain de sécurité intrinsèque (FISCO)
60079-28	op is op pr op sh	Protection du matériel et des systèmes de transmission utilisant le rayonnement optique	
Gc	60079-11	lc	Sécurité intrinsèque
	60079-18	mc	Encapsulage
	60079-15	nA	Matériel ne produisant pas d'étincelles
	60079-15	nR	Respiration limitée
	60079-15	nL	Énergie limitée (uniquement l'ancienne version)
	60079-15	nC	Matériel ne produisant pas d'étincelles
	60079-2	pz	Enveloppes à surpression interne
	60079-27		Concept de réseau de terrain de sécurité intrinsèque (FISCO)
60079-28	op is op pr op sh	Protection du matériel et des systèmes de transmission utilisant le rayonnement optique	

EPL = Niveau Protection Matériel



NORMES ET TYPE DE PROTECTION

MATÉRIEL ÉLECTRIQUE DESTINÉ À ÊTRE UTILISÉ EN PRÉSENCE DE POUSSIÈRES COMBUSTIBLES (GROUPE III)

EPL	Normes EN/CEI	Protection	Nom
	60079-0	-	Règles générales
Da	60079-31	ta	Protection par enveloppe
	60079-11	ia	Protection par sécurité intrinsèque (iaD CEI/EN 61241-11)
	61241-18	ma	Protection par encapsulage
Db	60079-31	tb	Protection par enveloppe
	60079-11	ib	Protection par sécurité intrinsèque (ibD CEI/EN 61241-11)
	60079-18	mb	Protection par encapsulage
	CEI 61241-4	pD	Type de protection "pD"
Dc	60079-31	tc	Protection par enveloppe
	60079-11	ic	Protection par sécurité intrinsèque
	60079-18	mc	Protection par encapsulage
	CEI 61241-4	pD	Type de protection "pD"

EPL = Niveau Protection Matériel

APPAREILS NON ÉLECTRIQUES DESTINÉS À ÊTRE UTILISÉS EN ATMOSPHÈRES EXPLOSIBLES

Normes	Protection	Nom
EN 13463-1	-	Méthodes et exigences de base
EN 13463-2	fr	Protection par enveloppe à circulation limitée
EN 13463-3	db	Protection par enveloppe antidéflagrante
EN 13463-5	c	Protection par sécurité de construction
EN 13463-6	b	Protection par contrôle de la source d'inflammation
EN 13463-7	p	Protection par pressurisation
EN 13463-8	k	Protection par immersion dans un liquide

ZONES ET NIVEAU DE PROTECTION (EPL)

Zone	Gaz	EPL	Zone	Poussières	EPL
0		Ga	20		Da
1		Ga et Gb	21		Da et Db
2		Ga, Gb et Gc	22		Da, Db et Dc

CATÉGORIES ET NIVEAU DE PROTECTION (EPL)

Catégories	Gaz	Poussières	Sécurité
1	Ga	Da	Niveau très élevé
2	Gb	Db	Niveau élevé
3	Gc	Dc	Niveau normal



EXEMPLES DE SIGNALISATION

**MATÉRIEL ÉLECTRIQUE POUR LES ATMOSPHÈRES EXPLOSIVES
GAZEUSES GROUPE II**

Ex de IIC T5 Gb

Groupes de matériel (Poussières)		Classe de température	Point d'inflammation du gaz ou de la vapeur	Température maximale de surface admise pour les surfaces constamment chaudes	Zone	Niveau de protection du matériel (EPL)
IIA	Acétone, éthane, benzène, benzine, butane, propane, méthane	T1	> 450°C	440°C	0	Ga
IIB	Éthylène, gaz de ville	T2	> 300°C	290°C	1	Gb et Ga
IIC	Hydrogène, acétylène	T3	> 200°C	195°C	2	Gc, Gb et Ga
		T4	> 135°C	130°C		
		T5	> 100°C	95°C		
		T6	> 85°C	80°C		

**MATÉRIEL ÉLECTRIQUE DESTINÉ À ÊTRE UTILISÉ EN PRÉSENCE
DE POUSSIÈRES COMBUSTIBLES (GROUPE III)**

Ex tb IIIC T95°C Db
Ex tb IIIC T95°C

Température de surface maxi.

Groupes de matériel (Poussières)	
IIIA	Fibres
IIIB	Poussières non conductrices
IIIC	Poussières conductrices

Zone	Niveau de protection du matériel (EPL)
20	Da
21	Db et Da
22	Dc, Db et Da



INFORMATIONS SUR LA DIRECTIVE (94/9/CE - 1994-03-23)

INFORMATIONS SUR LA DIRECTIVE (94/9/CE - 1994-03-23)

Conformément à la "**nouvelle approche**", la nouvelle directive pose les bases d'une harmonisation totale des règles dans ce domaine. Elle ne fait pas directement référence aux normes, mais définit les principales exigences à respecter en matière de santé et met en place la signalétique CE.

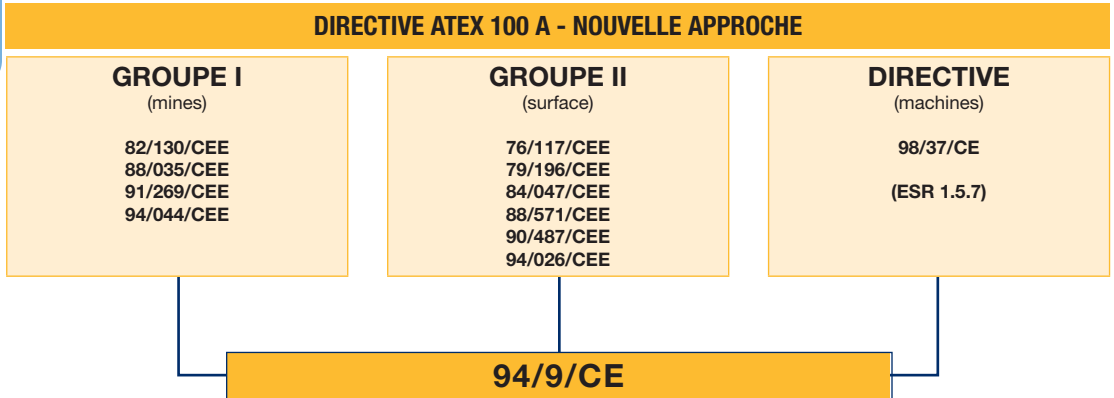

CADRE DE LA DIRECTIVE

Principes généraux de la nouvelle directive :

- Elle s'applique au matériel **électrique** et **non électrique**.
- Elle pose des règles **essentielles en matière de santé et de sécurité**.
- Elle prend en compte **tous les risques potentiels** que le matériel peut représenter, en particulier en matière de conception et de niveau de production.
- **Cette directive** s'applique à la fois aux **mines**, sujettes au grisou, et aux **industries de surface**.
- Elle souligne l'importance d'un matériel uniquement **utilisé conformément à l'usage auquel il est destiné**.
- Elle considère le Comité européen de normalisation **CEN** et le Comité européen de normalisation électrotechnique **CENELEC** comme des organismes compétents chargés de définir les normes requises.
- Elle s'applique à la fois aux **employés de main-d'œuvre et au personnel dirigeant**.
- Elle définit les **procédures d'évaluation de la conformité** sur la base de modules qui déterminent si le matériel peut ou non porter la signalisation **CE**.

APPLICATIONS

La directive s'applique au domaine de l'industrie et concerne le matériel suivant :

- **Équipement** (machines, appareils, etc.)
- **Systèmes de protection** (dispositifs de refoulement, dispositifs de suppression de l'explosion, etc.)
- **Composants** (parties sans fonction autonome, bornes, etc.)
- **Dispositifs de sécurité, de contrôle et de régulation non destinés** à des environnements potentiellement explosifs mais indispensables au fonctionnement des systèmes de sécurité antidéflagrants (relais, barrières, pressostats, thermostats, etc.)



INFORMATIONS SUR LA DIRECTIVE (94/9/CE - 1994-03-23)

MATÉRIEL NON CONCERNÉ PAR LA DIRECTIVE

Le matériel suivant n'est pas concerné par la nouvelle directive :

- Le matériel médical.
- Le matériel ou les systèmes de protection liés uniquement au risque d'explosion de produits chimiques instables (explosifs, etc.)
- Matériel domestique.
- Équipement de protection personnelle couvert par la directive 89/686/CE.
- Navires de haute mer et unités offshore mobiles.
- Moyens de transport, à l'exception des véhicules destinés à être utilisés dans des environnements potentiellement explosifs.

DATES D'ENTRÉE EN VIGUEUR

DIRECTIVE ATEX 100A - NOUVELLE APPROCHE

94/9/CE

Dates d'entrée en vigueur

• Intégration à la législation du pays	1/9/1995
• Entrée en vigueur (option)	1/3/1996
• Entrée en vigueur (totale)	1/7/2003

DES SOURCES INFLAMMABLES POTENTIELLES ET D'AUTRES RISQUES À SURVEILLER

Les phénomènes suivants représentent des risques potentiels :

- Différentes sources d'allumage, comme des étincelles, des flammes ou des arcs électriques ; des températures de surface élevées ; de l'énergie acoustique ; des radiations optiques ou des ondes électromagnétiques.
- Électricité statique.
- Opérations de compensation de pression.
- Perturbations provenant de l'extérieur comme des changements des conditions environnementales, une tension externe, de l'humidité, des vibrations ou des contaminations.

Des dispositions sont également prises concernant les conditions spécifiques s'appliquant aux dispositifs utilisés pour augmenter la sécurité de l'équipement.

Ces conditions requièrent une analyse détaillée afin que la fiabilité du fonctionnement de ces dispositifs et leur interaction avec d'autres composants liés à l'équipement puissent être examinées.



TABLEAU INFORMATIF POUR LES BARRIÈRES IS

Fabricant	Référence	Ex	Parties électriques standard IS							Parties électriques Booster IS			
			EX IA IIC T6 488650.01/02 488660.01 LCIE/AUS	Ex ia IIC T6 490885 490890 (490895) LCIE/FM/CSA	Ex ia IIC T6 483580.01/03 483960.01/03 LCIE/AUS	Ex ia 490880 (493997) LCIE/FM/CSA	Ex ia IIB T6 482160,01 LCIE	Ex ia IIC T6 482870,01 LCIE	Ex ia 492335 LCIE/FM/CSA	Ex ia IIC T6 492965.01/02 LCIE	Ex ia IIC T6 496565 LCIE	Ex ia IIC T6 495910 LCIE	
À puissance 3	NAEV 22-140	ia	●	-	●	-	●	●	-	●	●	●	
	NAEV 26-100	ia	●	-	●	-	●	●	-	●	●	●	
ABB	V171132-54	ib	●	-	●	-	●	●	-	●	●	●	
	V171132-55	ib	●	-	-	-	●	●	-	●	●	●	
	V171132-61	ia	●	-	-	-	●	●	-	●	●	●	
	DO 890	ib	●	-	●	-	●	●	-	●	●	●	
	S900-D04-EX	ib	●	-	-	-	●	●	-	●	●	●	
BRADLEY	FEX-EX 24V	ia	●	●	●	●	●	●	-	●	●	●	
COOPER	LB 2101	ia	●	●	●	●	●	●	●	●	●	●	
	LB 2105	ia	●	●	●	●	●	●	●	●	●	●	
	LB 2112	ia	●	●	●	●	●	●	●	●	●	●	
ELCON	1881/1882	ia	●	●	●	●	●	●	●	●	●	●	
	471/472	ia	●	●	●	●	●	●	●	●	●	●	
	2871/2872	ia	●	●	●	●	●	●	●	●	●	●	
GEORGIN	2874/2875/2876	ia	●	●	●	●	●	●	●	●	●	●	
	AVB 122	ia	●	-	●	-	●	●	-	●	●	●	
	AVB 125	ia	●	-	-	-	●	●	-	●	●	●	
	AVB 128	ia	●	-	●	-	●	●	-	●	●	●	
Hima	F3328A	ib	●	-	-	-	●	●	-	●	●	●	
	F3335	ib	●	-	-	-	●	●	-	●	●	●	
	H4007	ib	●	-	●	-	●	●	-	●	●	●	
MTL	728P, 7128P, 7728P	ia	-	-	-	-	●	●	-	●	●	●	
	728, 7028, 7128, 7728	ia	●	●	●	●	●	●	●	●	●	●	
	3021, 4021, 4021S	ia	●	-	●	-	●	●	-	●	●	●	
	3022	ia	-	-	-	-	●	-	-	-	-	-	
	4023	ia	-	-	-	-	●	-	-	-	-	-	
	4024	ia	●	-	●	-	●	●	-	●	●	●	
	4025	ia	●	●	●	●	●	●	●	●	●	●	
	5021, 5023, 5024	ia	●	-	●	-	●	●	-	●	●	●	
	5025	ia	●	-	●	-	●	●	●	●	●	●	
	4521/4523/4524	ia	●	-	-	-	●	●	●	●	●	●	
	5521/5523/5524	ia	●	-	-	-	●	●	●	●	●	●	
	Pepperl & Fuchs	Z 728	ia	●	●	●	●	●	●	●	●	●	●
		Z 779	ia	●	●	●	●	●	●	●	●	●	●
EGA-041-3		ia	-	●	●	●	●	●	●	●	●	●	
KFD2-SD-EX1.36		ia	-	-	-	-	-	●	-	-	-	-	
KFD2-SL-EX1.36		ia	-	-	-	-	-	●	-	-	-	-	
KFD2-SD-EX1.48		ia	-	●	-	●	-	●	●	●	●	●	
KFD2-SL-EX1.48		ia	-	●	-	●	-	●	●	●	●	●	
KFD2-SL- EX1.48.90A		ia	-	-	-	-	-	-	-	●	●	●	
KFD2-SL- EX1.48.90A		ia	-	-	-	-	-	-	-	●	●	●	
KFD2-SL2-EX1.LK		ia	-	●	-	●	-	●	●	●	●	●	
KFD2-SL2-EX2		ia	-	●	-	●	-	●	●	●	●	●	
KSD2-B0-EX		ia	-	●	●	●	●	●	●	●	●	●	
RSD-B0-EX4		ib	-	●	-	●	-	●	●	●	●	●	
RSD-V0-EX8	ib	-	-	-	-	-	-	-	●	●	●		



TABLEAU INFORMATIF POUR LES BARRIÈRES IS

Fabricant	Référence	Ex	Parties électriques standard IS						Parties électriques Booster IS			
			EX IA IIC T6 488650.01/02 488660.01 LCIE/AUS	Ex ia IIC T6 490885 490890 (490895) LCIE/FM/CSA	Ex ia IIC T6 483580.01/03 483960.01/03 LCIE/AUS	Ex ia 490880 (493997) LCIE/FM/CSA	Ex ia IIB T6 482160,01 LCIE	Ex ia IIC T6 482870,01 LCIE	Ex ia 492335 LCIE/FM/CSA	Ex ia IIC T6 492965.01/02 LCIE	Ex ia IIC T6 496565 LCIE	Ex ia IIC T6 495910 LCIE
SIEMENS	5RD00-OAB0	ib	-	-	-	-	-	-	-	●	-	-
	7RD00-OAB0	ia	-	-	-	-	-	-	-	●	●	●
	7RD01-OAB0	ia	-	-	-	-	-	-	-	●	●	●
	7RD10-OAB0	ia	-	-	-	-	-	-	-	●	●	●
	7RD11-OAB0	ia	-	-	-	-	-	-	-	●	●	●
	7RD20-OAB0	ia	-	-	-	-	-	-	-	●	●	●
	7RD21-OAB0	ia	-	-	-	-	-	-	-	●	●	●
STAHL	9001/01-252-100-14	ia	●	●	27 V	27 V	●	●	●	●	●	●
	9001/01-280-100-10	ia	●	●	24 V	24 V	●	●	●	●	●	●
	9001/01-280-110-10	ia	●	-	24 V	-	●	●	-	●	●	●
	9002/13-280-100-04	ia	24 V	24 V	27 V	27 V	24 V	24 V	24 V	17 V	17 V	17 V
	9311/52-11-10	ia	-	●	●	25 V	25 V	●	●	15 V	15 V	15 V
	9111/63-11-00	ia	-	●	●	25 V	25 V	●	●	15 V	15 V	15 V
	9351/10-15-10	ia	-	●	●	-	-	●	●	●	●	●
	9351/10-16-10	ia	-	●	●	●	-	●	●	●	●	●
	9351/10-17-10	ia	-	-	-	-	-	●	-	-	-	-
	9381/10-187-050-10	ib	-	●	●	●	●	●	●	●	●	●
	9381/10-246-055-10	ib	-	●	●	●	●	●	●	●	●	●
	9381/10-246-070-10	ib	-	●	●	●	●	●	●	●	●	●
	9465/12-04-11	ib	-	●	●	-	-	●	●	●	●	●
	9475/12-04-21	ia/ib	-	●	-	●	-	●	●	●	●	●
	9475/12-04-31	ia/ib	-	-	-	-	-	-	-	●	●	●
	9475/12-08-41	ia/ib	-	-	-	-	-	-	-	-	-	-
	9475/12-08-51	ib	-	-	-	-	-	-	-	-	●	●
	9475/12-08-61	ia/ib	-	-	-	-	-	-	-	-	●	●
	Turck	MK72-S01-EX	ib	-	-	-	-	●	●	-	●	●
MK72-S02-EEX		ib	-	-	-	-	●	●	-	●	●	●
MK72-S04-EEX		ib	●	-	●	-	●	●	-	●	●	●
MK72-S05-EEX		ib	●	-	-	-	●	●	-	●	●	●
MK72-S06-EEX		ib	●	-	●	-	●	●	-	●	●	●
MK72-S07-EEX		ib	●	-	-	-	●	●	-	●	●	●
MK72-S09-EEX		ia	-	-	-	-	-	-	-	-	-	-
MK72-S12-EEX		ia	●	-	●	-	●	●	-	●	●	●
MC72 - 41		ia	●	-	●	-	●	●	-	●	●	●
MC72 - 43		ia	●	-	●	-	●	●	-	●	●	●
MC72 - 44	ia	-	-	-	-	-	-	-	●	●	●	
BARTEC	07-7331-2301/1000	ia	●	-	-	-	●	●	-	●	-	-
	07-7331-2301/1100	ia	●	-	●	-	●	●	-	●	-	-

TABLEAU DES CODES TENSION POUR LES BOBINES ET LES PARTIES ÉLECTRIQUES

Ce tableau montre les codes tension les plus répandus. Pour d'autres tensions, veuillez nous contacter.

CODES TENSION			C1	C2	N7	L8	C4	C5	C7	E6	P1	A5	0A	S5	P2	1P	6J	0P	P3	K8	
Réf. bobine	Groupe électrique	Sous-groupe	12 CC	24 CC	28 CC	30 CC	48 CC	110 CC	196 CC	220 CC	100/50	100/50-60	110/50	110-115/50	110-115/50 120/60	110/50-60	110-115/50-60	110-115/60	100/50-115/60	110/50-120/60	115/60
481045	1.1	-	●	●			●	●						●							
481180	1.1	-	●	●										●							
481530	1.1	-	●	●																	
482605	1.1	-	●	●																	
482606	1.1	-	●	●			●	●						●				●			
483590	1.1	-													●						
488143	1.1	-										●									
488980	1.1	-	●	●			●	●						●				●			
492912	1.1	-		●																	
495865	1.1	-		●			●							●				●			
496131	1.2	-	●	●			●	●							●						●
496482	1.2	-	●	●			●	●							●						●
496637	1.2	-	●	●			●	●							●						●
WB4.5	1.3	-								●	●										●
WB5.0	1.3	-	●	●				●													
WB8.0	1.3	-																			●
481000	2.0	2.1	●	●			●	●		●				●				●			
481865	2.0	2.1	●	●			●	●						●							●
482635	2.0	2.1													●						
482725	2.0	2.1	●	●				●													●
483371	2.0	2.1	●	●			●	●		●				●				●			
483510	2.0	2.1													●						
483520	2.0	2.1																			
485100	2.0	2.1		●						●				●							
488553	2.0	2.1																			
488947	2.0	2.1									●										
491514	2.0	2.1	●	●		●															●
492070	2.0	2.1	●	●			●	●								●					
492190	2.0	2.1	●	●			●	●		●						●					
492453	2.0	2.1	●	●			●	●						●							
492670	2.0	2.1	●	●			●	●						●							
492726	2.0	2.1		●				●													
493640	2.0	2.1					●							●							●
494040	2.0	2.1		●						●				●							
495870	2.0	2.1					●	●						●							
495875	2.0	2.1		●										●							
495905	2.0	2.1		●			●	●													●
496081	2.0	2.1	●	●											●						
496082	2.0	2.1	●	●																	●
496110	2.0	2.1													●						
HZ10	2.0	2.1																			●
481044	2.0	2.2												●						●	
483816	2.0	2.2	●	●																	
486265	2.0	2.2	●	●			●							●					●		
492425	2.0	2.2	●	●										●							
492727	2.0	2.2	●	●																	
495880	2.0	2.2		●										●							
496155	2.0	2.2		●				●						●							
HZ11	2.0	2.2	●	●			●	●													●
482730	3.0	-		●			●							●							●
482735	3.0	-		●			●														

A1	1W	P6	S2			A7	B7	R5	3D	7J	3P	4K	Q3	S6	F4	J3	P9	A2	B2	P0		B8	Q1	A9	Q2	5P	A4	S4	T1		
12/50	12/50-60	200/50-60	200-230/60	208-230/60	208-240/60	220/50	220/60	220/50-60	220-230/50	220-230/60	220-230/50-60	220-240/60	220/50-240/60	220-240/50	230/50	230/60	230/50-60	24/50	24/60	24/50-60	240/50	240/60	240/50-60	380/50	380/50-60	380/50-440/60	48/50	48/50-60	230/50-240/60		

TABLEAU DES CODES TENSION POUR LES BOBINES ET LES PARTIES ÉLECTRIQUES

Ce tableau montre les codes tension les plus répandus. Pour d'autres tensions, veuillez nous contacter.

CODES TENSION			C1	C2	N7	L8	C4	C5	C7	E6	P1	A5	0A	S5	P2	1P	6J	0P	P3	K8		
Réf. bobine	Groupe électrique	Sous-groupe	12 CC	24 CC	28 CC	30 CC	48 CC	110 CC	196 CC	220 CC	100/50	100/50-60	110/50	110-115/50	110-115/50 120/60	110/50-60	110-115/50-60	110-115/60	100/50-115/60	110/50-120/60	115/60	
484990	4.0	-																				
485400	4.0	-	●	●			●	●									●					
495915	4.0	-		●			●										●					
482740	6	-					●	●														
482745	6.0	-		●																		
495900	6.0	-	●	●			●	●														●
496125	6.0	-		●			●	●														
483580.01	7.0	-			●																	
488650.01	7.0	-			●																	
488660.01	7.0	-			●																	
488670.01	7.0	-			●																	
490885	7.0	-				●																
490890	7.0	-			●	●																
495910	8.0	-			●																	
492210	9.0	-		●																		
492965.01	9.0	-			●																	
496565	9.0	-			●																	
492300	10.1	-	●	●			●	●		●						●						
492310	10.1	-	●	●			●	●		●						●						
496560	10.1	-		●			●	●														
496800	10.1	-		●			●	●														
496895	10.1	-		●			●	●														
496555	10.2	-		●			●	●								●						
496700	10.2	-		●			●	●								●						
483270	11.0	-	●	●			●	●														
483270.02	11.0	-	●	●			●	●									●					
492335	12.0	-				●																
482870.01	12.0	-			●																	
495294	13.0	-	●	●																		
496193	13.0	-	●	●																		
483541	14.1	-																				
483824	14.1	-																				
483764	14.2	-																				
YB09	20.1	-																●			●	
YB12	20.1	-	●	●																		
ZB09	20.1	-	●	●				●			●						●				●	
ZB12	20.1	-	●	●			●	●														
ZB14	20.2	-									●										●	
ZB16	20.2	-	●	●				●														
ZH14	20.2	-																			●	
ZH16	20.2	-	●	●																		
JB14	21.0	-																				
JB16	21.0	-	●	●					●													
KH09	22.0	-																				
KP10	22.0	-	●	●																		
KT09	22.0	-												●								
XT09	23.0	-																				
D4	24.0	-		●																	●	
D5	24.0	-		●																		●
LA	24.0	-		●									●								●	
LB-LC	24.0	-		●																	●	
XS03	24.0	-																			●	

A1	1W	P6	S2		A7	B7	R5	3D	7J	3P	4K	Q3	S6	F4	J3	P9	A2	B2	P0	B8	Q1	A9	Q2	5P	A4	S4	T1		
12/50	12/50-60	200/50-60	200-230/60	208-230/60	208-240/60	220/50	220/60	220/50-60	220-230/50	220-230/60	220-230/50-60	220-240/60	220/50-240/60	220-240/50	230/50	230/60	230/50-60	24/50	24/60	24/50-60	240/50	240/60	240/50-60	380/50	380/50-60	380/50-440/60	48/50	48/50-60	230/50-240/60
										•										•							•		
										•											•						•		
														•			•									•			

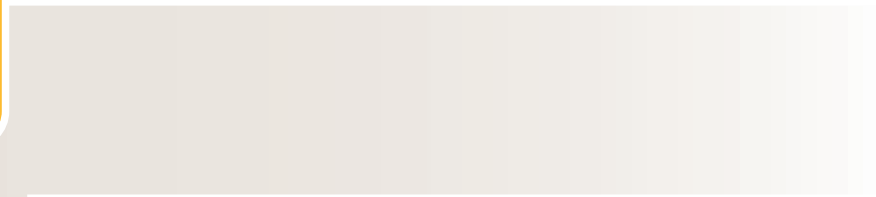

DONNÉES TECHNIQUES SUR LES ÉLECTROVANNES

DONNÉES TECHNIQUES SUR LES ÉLECTROVANNES

Généralités

Les électrovannes sont des dispositifs électromécaniques qui permettent d'interrompre ou de dévier le débit des fluides en ouvrant ou en fermant un ou plusieurs orifices.

L'électrovanne comporte trois composants de base :

1. Un électro-aimant constitué d'une solénoïde (enroulements) et d'une culasse d'alimentation magnétique.
2. Un pilote équipé d'un plongeur mobile (qui dans certains cas ouvre et ferme directement la vanne).
3. Un corps de vanne avec un orifice ouvert ou fermé par un plongeur ou une membrane pour permettre ou empêcher le fluide de circuler.

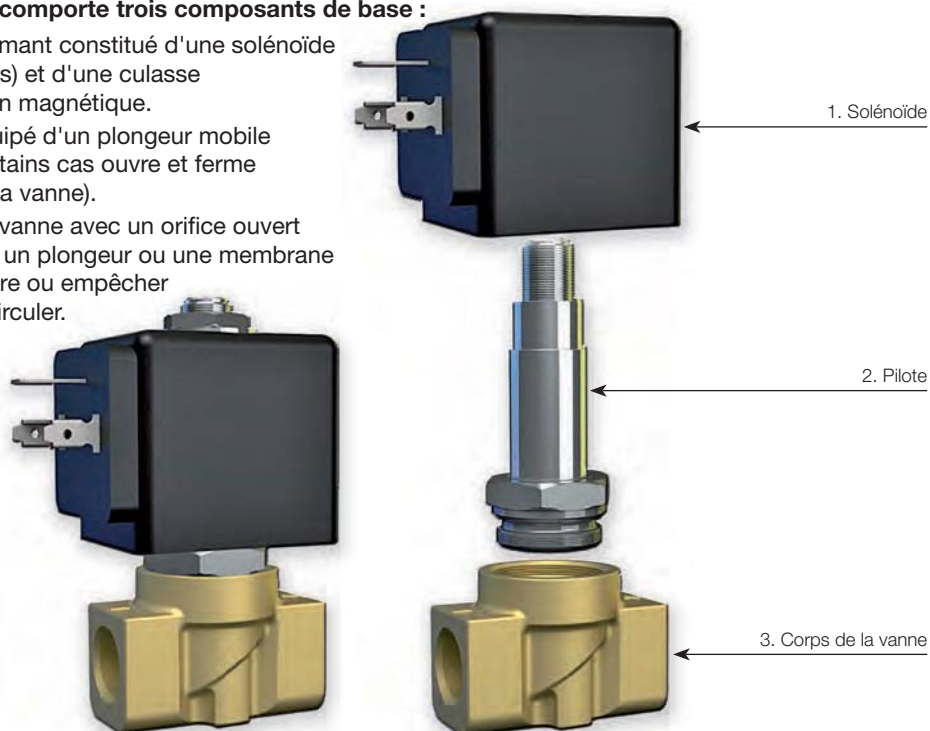

Principes de fonctionnement

Le terme « solénoïde » renvoie à l'actionneur et à la bobine, également appelés « pilote » ou « actionneur magnétique ».

La bobine est constituée d'un fil de cuivre enroulé autour d'un châssis. Lorsque le courant électrique pénètre dans la bobine, les lignes de flux magnétique générées sont plus fortes au centre de la bobine.

Le flux magnétique soulève le plongeur mobile dans la bobine jusqu'à ce qu'il entre en contact avec l'élément de pôle. Le corps de la vanne comporte un orifice à travers lequel le liquide circule lorsque la vanne est ouverte.

Le plongeur comporte un siège intégral qui, lorsque la bobine de solénoïde est mise sous tension, déplace l'orifice de la vanne (commande directe) ou l'orifice de la membrane (commande de pilote) ouvrant la vanne.

Lorsque la bobine n'est plus alimentée, un ressort de rappel ramène le plongeur sur la position de fermeture d'origine, interrompant le flux du fluide.

COMPOSANTS DE BASE D'UNE ÉLECTROVANNE

- Corps de la vanne :** Partie principale de l'électrovanne comprenant les raccords, les sièges et les orifices.
- Tube d'électrovanne :** Cylindre en acier inoxydable, hermétiquement scellé et fermé à une extrémité. Désigne le canal de guidage du plongeur mobile déplacé magnétiquement. La bobine de solénoïde est fixée sur la paroi extérieure du tube intégré.
- Plongeur mobile :** Composé d'acier inoxydable ferritique, il est attiré par le champ magnétique du solénoïde et glisse dans le tube.
- Ressort du plongeur (ou ressort de rappel) :** Utilisé pour maintenir le plongeur mobile en place et le ramener dans sa position lorsqu'il n'est pas plus alimenté.
- Joint de siège :** Monté sur le plongeur mobile, il est utilisé pour fermer l'orifice principal de la vanne ou l'orifice pilote.
- Électro-aimant (ou bobine de solénoïde) :** Pièce électrique composée d'enroulements en cuivre (solénoïde) et d'une culasse d'alimentation magnétique (armature). Lorsque le courant électrique la traverse, il génère un flux magnétique qui attire le plongeur mobile.
- Boîtier :** Pièce contenant et protégeant la bobine.
- Culasse :** Boîtier métallique entourant la bobine et concentrant la force électromagnétique sur le plongeur mobile.

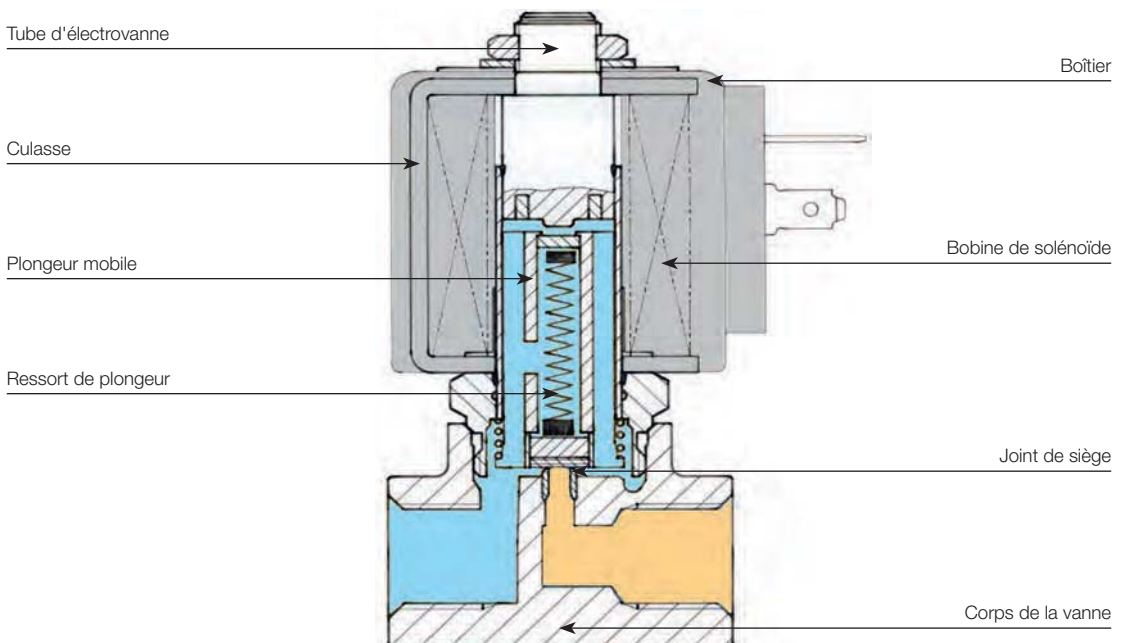

TERMINOLOGIE TECHNIQUE EMPLOYÉE DANS LES TABLEAUX

Commande	Corps de valve	Fonction	Raccord	Orifice (mm)	Facteur d'écoulement Kv(l/min)	Pression Différentielle (bar)	Temp. Max. Fluide (°C)	Page Valves Parker	Page Valves Parker LUCIFER®
----------	----------------	----------	---------	--------------	--------------------------------	-------------------------------	------------------------	--------------------	-----------------------------

NORMALEMENT FERMÉE

Raccord	Orifice Ø	Facteur d'écoulement			Pression différentielle		Temp. Fluide		Joint	ELECTROVANNES Parker LUCIFER®			Puissance		Groupe électrique	N° Schéma
					Mini.	Maxi. (MOPD)	Mini.	Maxi.		Réf. Valve	Réf. boîtier	Réf. bobine	CA W	CC W		
BSP	mm	Kv l/min	KV m³/h	Qn l/min	bar	CA bar	CC bar	°C	°C							

Les caractéristiques techniques de base de chaque modèle d'électrovanne sont indiquées dans les tableaux ; la terminologie utilisée est expliquée ci-dessous. Remarque : dans certains chapitres, deux gammes de produits sont disponibles, les vannes Parker dans les tableaux bleus et les vannes Parker Lucifer dans les tableaux orange.

- Commande :** Type de commande, pour le contrôle du débit.
- Corps de valve :** Partie principale de l'électrovanne comprenant les raccords, les sièges et les orifices nécessaires.
- Fonction :** Désigne le mode de fonctionnement des vannes lorsque celles-ci ne sont pas alimentées.
- Raccord :** Les dimensions des raccords sont définies comme filetés en pouces (G), en BSP ou embase, lorsqu'une interface plate est adoptée pour les raccords.
- Orifice (mm) :** Diamètre de l'orifice principal en millimètres (diamètre nominal).
- Facteur d'écoulement :** Désignent le volume d'eau qui circule dans l'électrovanne avec une chute de pression de 1 bar pendant une minute. Exprimés en l/min et en m³/h.
- Température maximale du fluide :** Température maximale du fluide que la vanne peut supporter.
- Température ambiante maximale :** Température ambiante maximale que la vanne peut supporter.
- Pression différentielle minimale de service :** Pression différentielle la plus basse requise pour le fonctionnement (en bar).
- Pression différentielle maximale de service (MOPD) :** Désigne la pression différentielle de service la plus élevée avec 90 % de la tension nominale (-10 % Vn) appliquée sur la bobine de solénoïde (CA) et 95 % de la tension nominale (-5 % Vn)(CC).

NORMALEMENT FERMÉE

Rac- cord	Orifice Ø	Facteur d'écoulement			Pression différentielle			Temp. Fluide		Joint	Vannes Parker			Puissance		Groupe élec- trique	N° Sché- ma
		Kv l/min	KV m ³ /h	Qn m ³ /h	Mini. bar	Maxi. (MOPD) CA bar	CC bar	Mini. °C	Maxi. °C		Numéro de commande valve	Type de valve	Type de bobine	CA W	CC W		
BSP	mm																

- Température du fluide :** Températures minimale et maximale admissibles pour le milieu utilisé (°C).
- Joint de siège :** Matériau utilisé pour les disques de siège.
- Numéro de commande de vanne :** Désigne les vannes Parker figurant dans les tableaux [bleus](#). Le numéro de commande de vanne désigne les vannes uniquement (Voir le chapitre « Comment passer commande » pour en savoir plus).
- Référence de vanne :** Désigne les vannes Parker figurant dans les tableaux [orange](#). La référence de vanne désigne la vanne (Voir le chapitre « Comment passer commande » pour en savoir plus).
- Type de vanne :** Désigne le type de vanne Parker
- Référence de boîtier :** Pour les vannes Parker Lucifer figurant dans les tableaux [orange](#), vous pouvez choisir le boîtier de protection de la bobine.
- Référence de bobine :** Référence de la bobine compatible.
- Type de bobine :** Bobine compatible conseillée.
- Alimentation :** Consommation électrique d'un composant du réservoir sous pression sélectionné, indiquée en CA et CC (W). La consommation électrique doit être évaluée à froid, avec une température ambiante de +20°C. Pour les séries 483510, 481865 et 496081, la consommation électrique indiquée dans les tableaux doit être mesurée à chaud.
- Groupe électrique :** Reportez-vous au chapitre correspondant pour consulter les Groupe électrique compatibles.
- N° Schéma :** Numéro de schéma.

DONNÉES TECHNIQUES

Les électrovannes sont des produits extrêmement élaborés pouvant être utilisés dans de nombreux champs d'application.

Elles sont en outre fiables et compatibles avec différents milieux et environnements, dans la mesure où l'utilisateur a opté pour le modèle répondant le mieux à ses besoins.

Ce chapitre présente brièvement les composants, ainsi que les modes d'actionnement et de fonctionnalité des électrovannes Parker Hannifin - FCDE.

Plusieurs technologies :

Les électrovannes sont des dispositifs à commandes électriques utilisés pour contrôler le débit. Types d'électrovannes les plus courants :



Vannes à attraction forcée



Vannes à commande directe

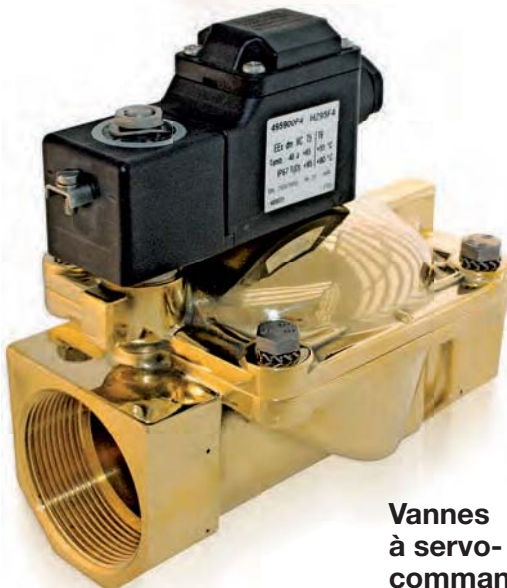

Vannes à servo-commande

VANNE À COMMANDE DIRECTE

La force magnétique permet d'ouvrir ou de fermer le plongeur pour contrôler la circulation du fluide. Les performances dépendent de la bobine, de la pression et de la dimension de l'orifice de la vanne. Pour les vannes à commande directe, la pression de service minimale est de 0 bar et la pression maximale dépend de la combinaison vanne/bobine choisie.

Vanne à commande directe

Non alimentée

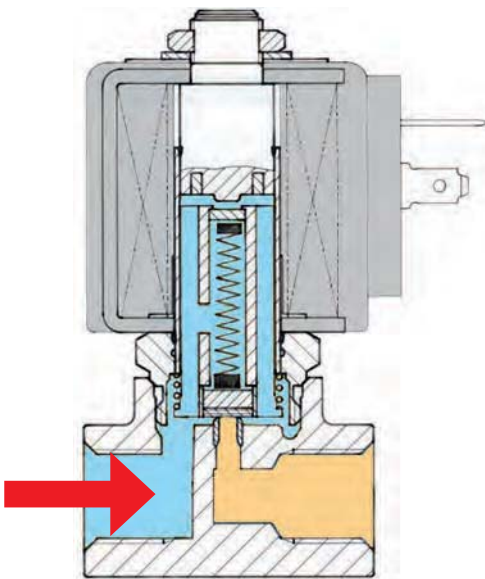

Alimentée

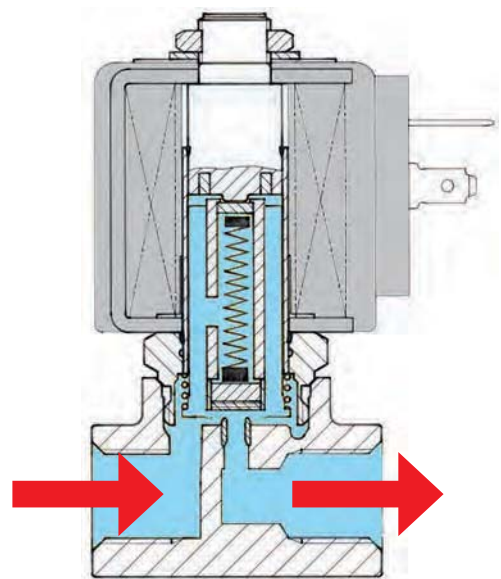

Exemple :

- Série 121
- Série 146
- Série N74

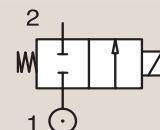

VANNE À SERVO-COMMANDE

Les vannes à servo-commande permettent de contrôler des débits plus élevés. La pression d'alimentation arrive dans le « niveau pilote » à commande directe qui dirige le flux vers la « chambre pilote », qui vient alors exercer une pression sur une grande surface (généralement une membrane ou un piston). La force ainsi créée permet de déplacer les éléments d'étanchéité principaux contre une pression élevée ou par un orifice large. Pour que la vanne fonctionne correctement, une pression minimale est requise (voir le catalogue). Cela ne présente pas de problème particulier pour la plupart des applications (voir le chapitre consacré à la vanne Magnalift). La pression nominale commence entre 0,1 et 0,5 bar (en fonction du type de vanne).

Vanne à servo-commande

Non alimentée

Alimentée

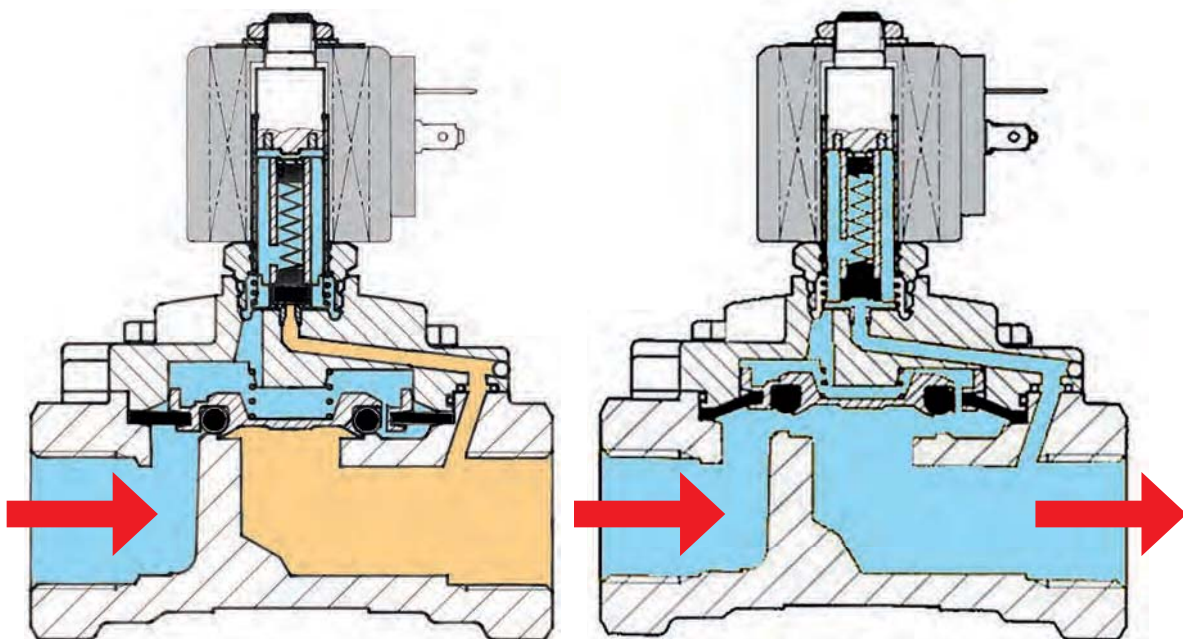

Exemple :

- Série 321
- Série 7321B
- Série 168.1

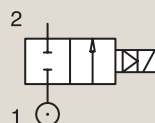

VANNE À ATTRACTION FORCÉE

Les vannes à attraction forcée combinent les caractéristiques des vannes à commande directe et des vannes à servo-commande. Une liaison mécanique reliant le plongeur au dispositif de retenue de la membrane permet à la vanne de fonctionner comme une vanne à commande directe, à des pressions faibles, et comme une vanne à servo-commande, à des pressions plus élevées. Les vannes à attraction forcée sont spécialement conçues pour être utilisées dans des champs d'application nécessitant une pression nulle ou un débit plus important qu'avec une vanne à commande directe.

Vanne à attraction forcée

Non alimentée

Alimentée

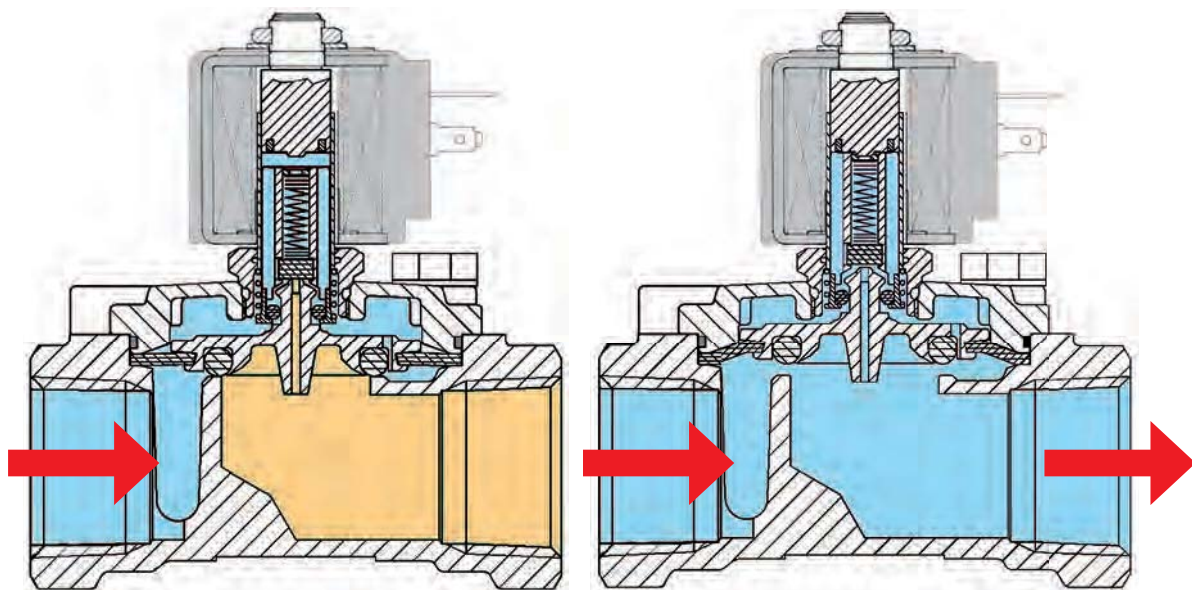

Exemple :

- Série 221
- Série 123

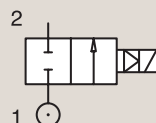

VANNE NORMALEMENT FERMÉE

La plupart de nos vannes sont disponibles dans les deux configurations (normalement fermée et normalement ouverte) lorsqu'elles ne sont pas alimentées. Pour certains champs d'application, vous aurez peut-être besoin d'une vanne normalement ouverte (ouverte en cas de coupure de courant). Le facteur de différenciation de cette configuration réside dans la conception du joint de siège, qui est inversé par rapport à une vanne normalement fermée.

Vanne normalement fermée

Non alimentée

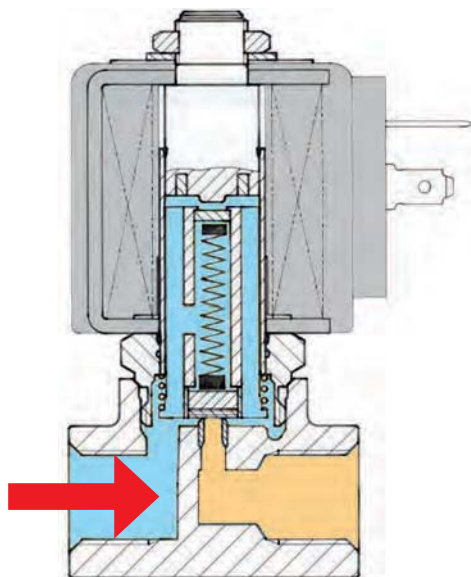

Alimentée

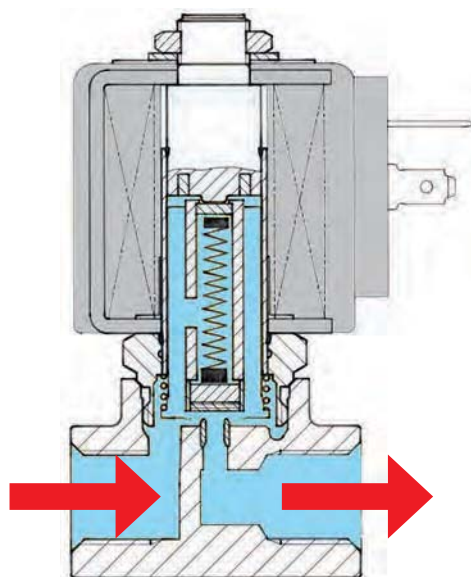

Exemple :

- Série 121
- Série 146
- Série N74

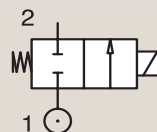

VANNE NORMALEMENT OUVERTE

Vanne normalement ouverte

Non alimentée

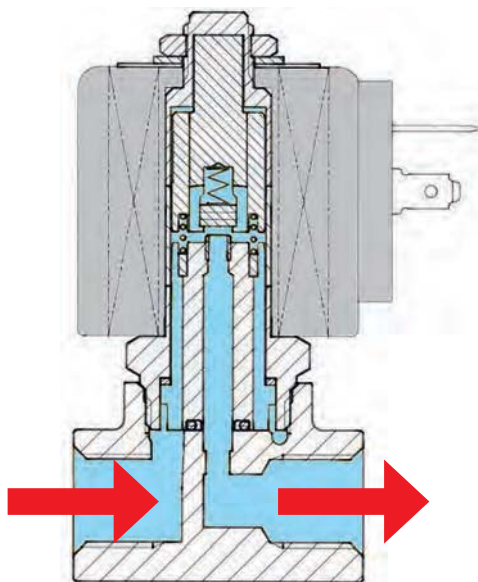

Alimentée

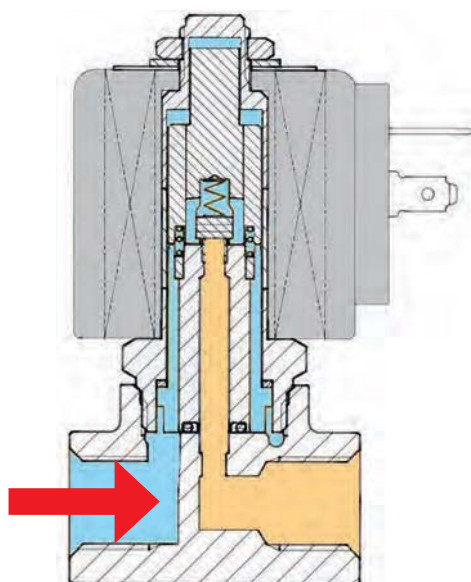

Exemple :

- Série 122
- Série 136
- Série 7322B

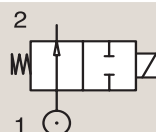

PLAGES DE DÉBITS ET DE PRESSIONS

Champ d'application :

Comme il a été mentionné dans les pages précédentes, chaque vanne est associée à un champ d'application bien défini en fonction de ses caractéristiques de pression et de débit. Le graphique ci-dessous montre à quel champ d'application sont associées les différentes vannes.

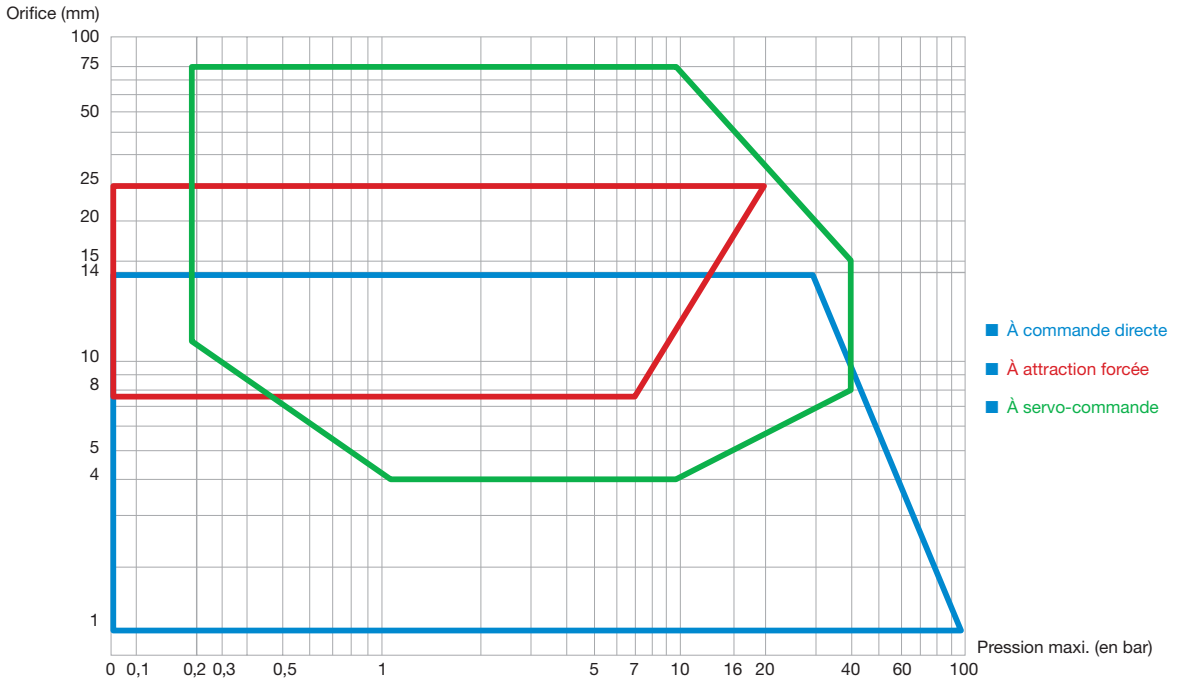

Champs d'application des électrovannes Parker.

DIMENSIONNEMENT DES ÉLECTROVANNES

Le choix de l'électrovanne est essentiel, car c'est elle qui décide de la régulation et des performances à appliquer sur un système. Pour sélectionner l'électrovanne la mieux adaptée à vos besoins, il convient de prendre en compte plusieurs paramètres.

La méthode de calcul utilisée, basée sur le coefficient de débit K_v , s'est avérée très pratique car elle permet d'identifier la bonne électrovanne sur la base des éléments suivants :

- Débit requis
- Résistance à l'écoulement
- Type de fluide et viscosité relative
- Densité et température

Le coefficient de débit K_v est calculé conformément aux normes VDI/VDE 2173.

Il représente le débit d'eau en m^3/h ou en l/min circulant dans l'électrovanne à une température comprise entre 5 et 30°C et à une pression de 1 bar.

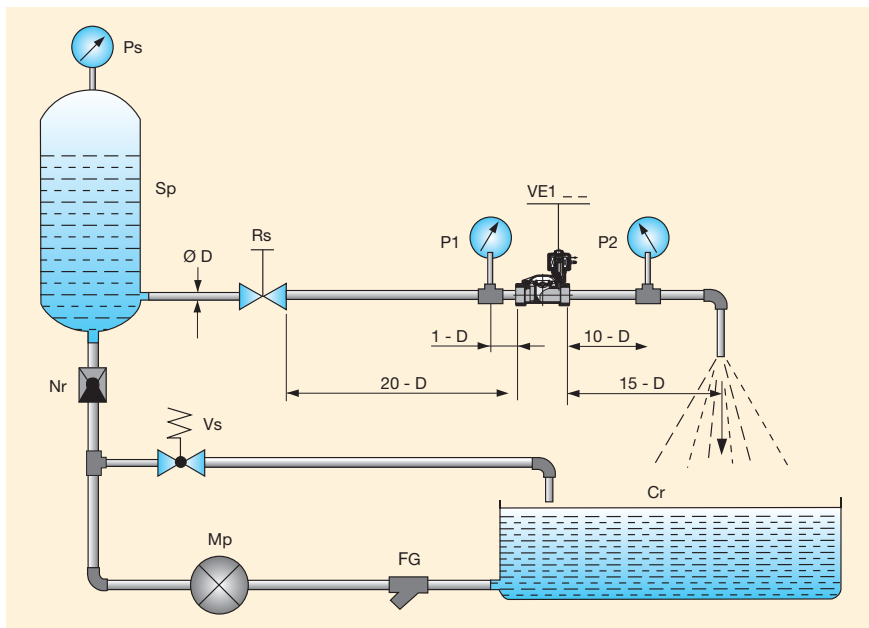

Remarque :

Aux États-Unis, le coefficient de débit se mesure en C_v et représente le débit d'eau en gallons américains par minute circulant avec une chute de pression ΔP de 1 psi.

Pour convertir des C_v en K_v et inversement :

1 K_v = 0,862 C_v
1 C_v = 1,16 K_v

FG = Filtre de la grille **Mp** = Pompe **Vs** = Vanne de sécurité **Nr** = Vanne anti-retour
Sp = Réservoir de pression **Ps** = Manomètre pression statique

Une fois la conversion effectuée (en K_v), reportez-vous au chapitre concerné pour rechercher le type de vanne approprié.

Les paramètres de recherche figurent dans le tableau situé en page suivante.

Reportez-vous aux tableaux de conversion des différentes unités de mesure telles que définies par l'Organisation internationale de normalisation ISO (International Standards Organisation) et le Système international d'unités (SI).

PLAGES DE DÉBITS ET DE PRESSIONS

<p>Pression</p> <p>symbole (P)</p> <p>unité de mesure [bar]</p> <p>Pression de service</p>		<p>Température du milieu</p> <p>symbole (t)</p> <p>unité de mesure [°C]</p>	
<p>Chute de pression</p> <p>symbole (ΔP)</p> <p>unité de mesure [bar]</p> <p>Différence de pression entre l'entrée (P₁) et la sortie (P₂) de l'électrovanne lorsqu'un milieu circule dans la vanne (ΔP = P₁ - P₂).</p>		<p>Débit</p> <ul style="list-style-type: none"> pour les liquides <p>symbole (Q)</p> <p>unité de mesure [m³/h]</p> <ul style="list-style-type: none"> pour les gaz <p>symbole (Qn)</p> <p>unité de mesure [Nm³/h]</p> <ul style="list-style-type: none"> pour la vapeur <p>symbole (Qv)</p> <p>unité de mesure [kg/h]</p>	
<p>Facteur d'écoulement</p> <p>symbole (Kv)</p> <p>unité de mesure [m³/h]</p>		<p>Volume spécifique</p> <p>symbole (Vs)</p> <p>unité de mesure [m³/kg]</p>	
<p>Densité du milieu</p> <p>symbole (γ)</p> <p>unité de mesure [kg/dm³]</p>			

a) Electrovanne pour les liquides :

Débit : $Q = K_v \cdot \sqrt{\frac{\Delta P}{\gamma}}$ où : $Q = \text{m}^3/\text{h}$
 $\Delta P = \text{bar}$
 $\gamma = \text{kg}/\text{dm}^3$

Facteur d'écoulement :

$$K_v = Q \cdot \sqrt{\frac{\gamma}{\Delta P}}$$

Pour les liquides dont la viscosité est supérieure à 3°E (22 cSt), la valeur Kv change :

$$K_{v1} = K_v + C \quad C = \frac{\delta \cdot \sqrt{K_v}}{200 \cdot Q}$$

où C correspond au coefficient de correction de la viscosité calculé selon la formule suivante :

où :

δ = viscosité cinématique du fluide exprimée en centistokes

Kv = coefficient de débit de l'électrovanne

Q = débit en m³/h.

Chute de pression :

$$\Delta P = \gamma \cdot \left(\frac{Q}{K_v}\right)^2$$

b) Électrovannes pour les gaz :

Si $\Delta P \leq 1/2 P_1$, utilisez les formules suivantes :

Débit :
$$Q_n = 514 \cdot K_v \cdot \sqrt{\frac{\Delta P \cdot P_2}{\gamma_n \cdot (273 + t)}}$$

où : $Q_n = \text{Nm}^3/\text{h}$ $P_1 = \text{bar}$ $P_2 = \text{bar}$

Facteur d'écoulement :
$$K_v = \frac{Q_n}{514} \cdot \sqrt{\frac{(273+t) \cdot \gamma_n}{\Delta P \cdot P_2}}$$

$t = ^\circ\text{C}$
 $\gamma_n = \text{kg}/\text{m}^3$

Chute de pression :
$$\Delta P = \frac{(273 + t) \cdot \gamma_n \cdot Q_n^2}{P_2 \cdot (514 \cdot K_v)^2}$$

Si $\Delta P > 1/2 P_1$, utilisez les formules suivantes :

$$Q_n = 757 \cdot K_v \cdot \sqrt{\frac{\Delta P \cdot P_2}{(273 + t) \cdot \gamma_n}}$$

c) Électrovannes pour la vapeur :

Si $\Delta P \leq 1/2 P_1$, utilisez les formules suivantes :

Débit :
$$Q_v = 31,7 \cdot K_v \cdot \sqrt{\frac{\Delta P}{V_s}}$$

où : $Q_v = \text{kg}/\text{h}$ $\Delta P = \text{bar}$ $V_s = \text{m}^3/\text{kg}$

Coefficient de flux :
$$K_v = \frac{Q_v}{31,7} \cdot \sqrt{\frac{V_s}{\Delta P}}$$

Chute de pression :
$$\Delta P = V_s \cdot \frac{Q_v^2}{(31,7 \cdot K_v)^2}$$

Si $\Delta P > 1/2 P_1$, utilisez les formules suivantes :

$$Q_v = 22,4 \cdot K_v \cdot \sqrt{\frac{P_1}{V_s}}$$

Remarques :

1) Si la valeur ΔP n'est pas précisée, utilisez la valeur empirique suivante :

- Pour les liquides, uniquement en cas de refoulement libre, $\Delta P = 90 \%$ de la pression d'entrée (P_1).
- Pour les gaz, la valeur ΔP ne doit pas dépasser 50% de la pression d'entrée absolue (une chute de pression trop importante risque d'entraîner une irrégularité du débit. Dans la plupart des cas, la valeur ΔP correspond à 10% de la pression d'entrée).

2) Valeur du volume spécifique (V_s) pour la vapeur sèche saturée : voir le tableau dans le schéma 3.

DÉBIT DES LIQUIDES

Le débit de liquide dans une vanne se calcule à l'aide de la formule suivante :

$$Q = K_v \cdot \sqrt{\frac{\Delta P}{\gamma}}$$

- Où
- Q** = Débit [l/min]
 - ΔP** = Pression différentielle [bar]
 - γ** = Densité du fluide [kg/dm³]
(eau γ = 1 [kg/dm³])
 - kv** = Facteur d'écoulement [m³/h]

Facteur d'écoulement kv :

Le Facteur d'écoulement kv d'une vanne correspond au débit d'eau en litres par minute associé à une chute de pression de 1 bar dans la vanne.

Les fabricants de vannes utilisent plusieurs définitions pour la valeur kv. Elle peut être exprimée en l/h ou en m³/h.

Faites donc particulièrement attention lorsque vous comparez des valeurs.

Débit maximum Qmax.

Pour les vannes à 2 voies, le débit maximal doit être limité pour des raisons de résistance technique et de durabilité.

Un débit trop rapide risque de détruire un joint clapet ou une membrane.

Les débits maximums sont indiqués dans le catalogue.

Coefficients de débit

Kv l/min	KV m ³ /h	Qn l/min
--------------------	--------------------------------	--------------------

NORMALEMENT FERMÉE

Racord	Orifice Ø	Facteur d'écoulement			Pression différentielle		Temp. Fluide		Joint	ELECTROVANNES Parker LUCIFER®			Puissance		Groupe électrique	N° Schéma
		Kv l/min	KV m ³ /h	Qn l/min	Mini. bar	Maxi. (MOPD) CA bar CC bar	Mini. °C	Maxi. °C		Réf. Valve	Réf. boîtier	Réf. bobine	CA W	CC W		
BSP	mm															

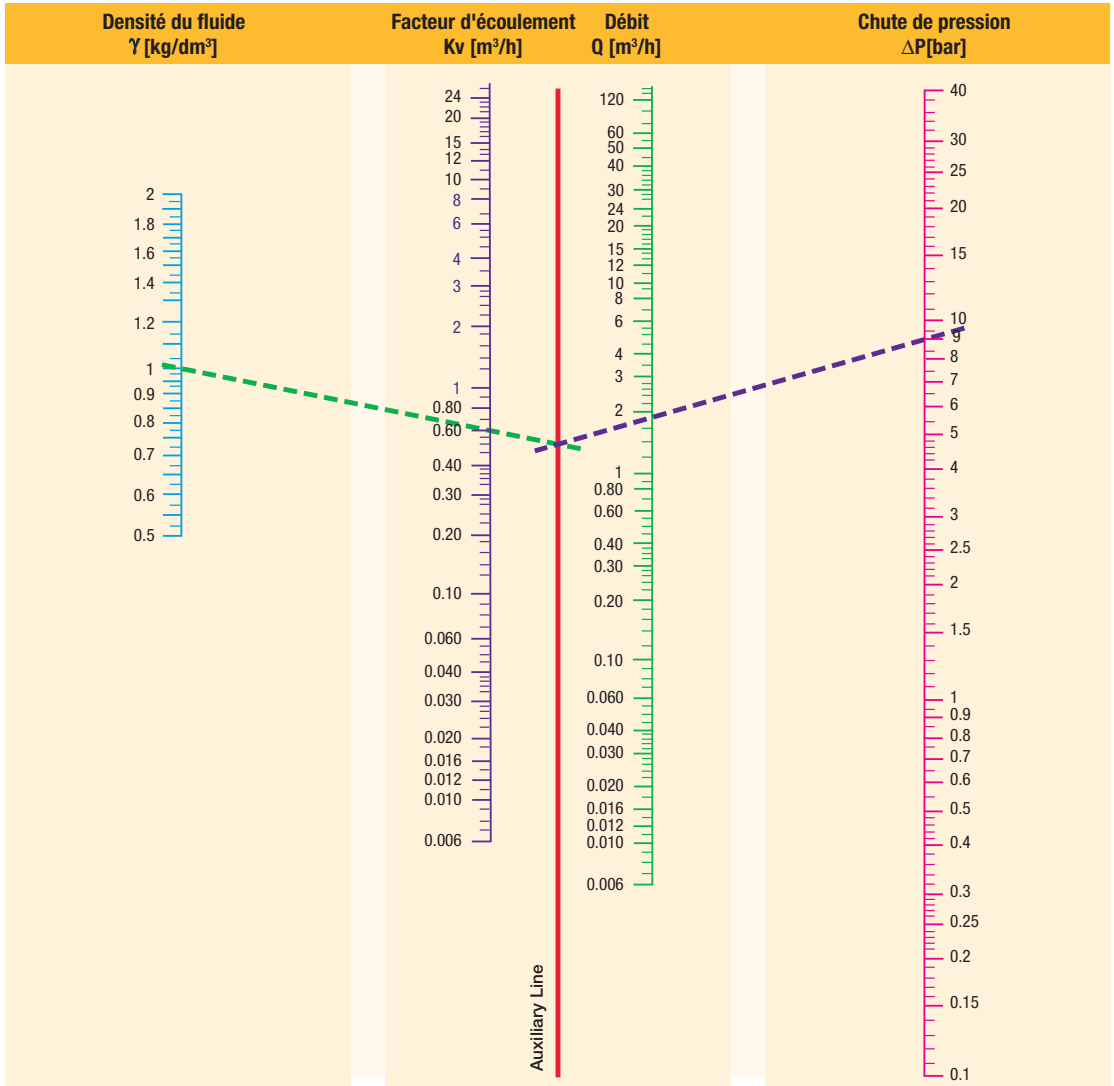

Graphique représentant le calcul du débit de liquide

Densité de la plupart des fluides communs ($\gamma = \text{kg/dm}^3$) - ($t = 15\text{ }^\circ\text{C}$ - $P = 760\text{ mm Hg}$)			
Acétone	0,76	Phénol	0,90
Eau	1	Bière	1,02
Eau de mer	1,02	Hexane	0,66
Éthanol	0,79	Éthane	0,68
Méthanol	0,81	Carburant diesel	0,70
Essence	0,68	Lait	1,03
		Naphte	0,76
		Pentane	0,63
		Huile végétale	0,92
		Huile hydraulique	0,92
		Vin	0,95

DÉBIT DES GAZ

Le débit de gaz dans une vanne se calcule à l'aide de la formule suivante :

$$Q = C \cdot P_1 \cdot k_T \cdot \omega \cdot \gamma_{\text{air}} / \gamma_{\text{gaz}}$$

Où

- Q** = Débit [dm³/s]
- C** = Conductance [dm³/s.bar]
- P** = Pression d'entrée [bar abs]
- γ** = Densité relative [kg/m³]
- k_T** = Facteur de correction de température

$$\omega = \sqrt{1 - \frac{P_2/P_1 - b}{1 - b}}$$

$$k_T = \sqrt{\frac{293}{273 + \text{Temp. } ^\circ\text{C}}}$$

Débit nominal Qn :

Le calcul peut être effectué à l'aide de Facteur d'écoulement spécifiques basés sur la norme CETOP RP 50P.

Par souci pratique et pour faciliter la recherche, le catalogue indique le débit nominal Qn.

Le débit nominal Qn correspond au débit (l/min) d'air traversant la vanne lorsque la pression d'entrée P₁ = 6 bar et que la chute de pression ΔP = 1 bar.

N.B.

Les coefficients de débit et les débits indiqués dans les catalogues sont soumis à des tolérances de +/-15 %.

Application pneumatique : $\gamma_{\text{air}} / \gamma_{\text{gaz}} = 1$

a) Conditions de débit critique P₂ ≤ b.P₁

Dans ce cas ω = 1 --> Q = C . P₁ . kT

b) Conditions de débit intégral P₂ > b.P₁

Dans ce cas --> Q = C . P₁ . kT . ω

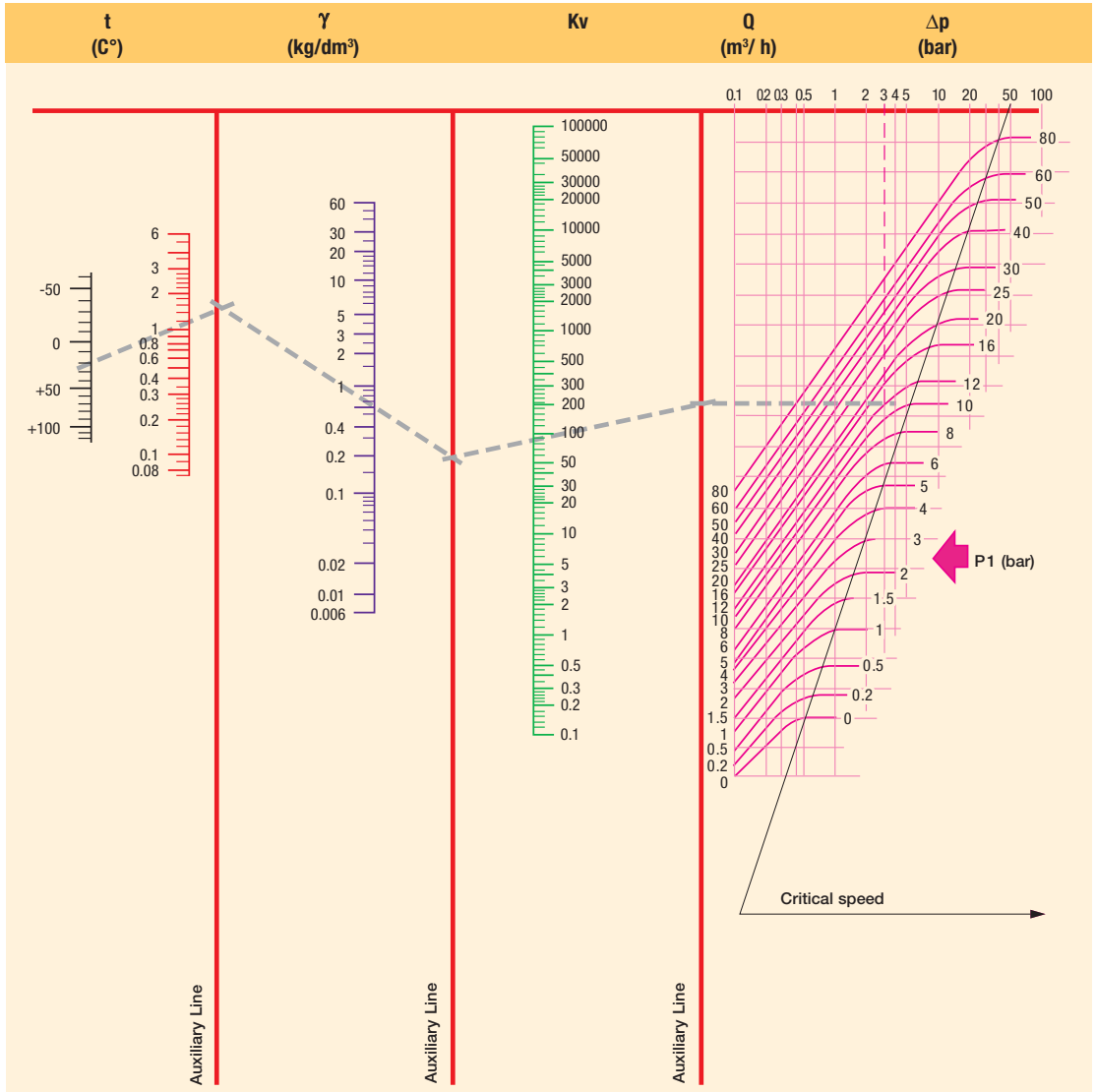

t = Température du fluide γN = Densité Kv = Facteur d'écoulement Qn = Débit Δp = Chute de pression P1 = Pression d'entrée

Densité de la plupart des gaz communs (γ = kg/m³) - (t = 0°C - P = 760 mm Hg)

Acétylène	1,176	Hélium	0,179	Gaz naturel	0,723
Dioxyde de carbone	1,965	Éthane	1,035	Méthane	0,722
Air	1,293	Éthylène	1,259	Monoxyde de carbone	1,25
Argon	1,78	Hydrogène	0,089	Oxygène	1,429
Azote	1,255			Propane	1,52
Butane	2			Vapeur	0,805

DONNÉES TECHNIQUES

Schéma 3 sur la vapeur sèche saturée

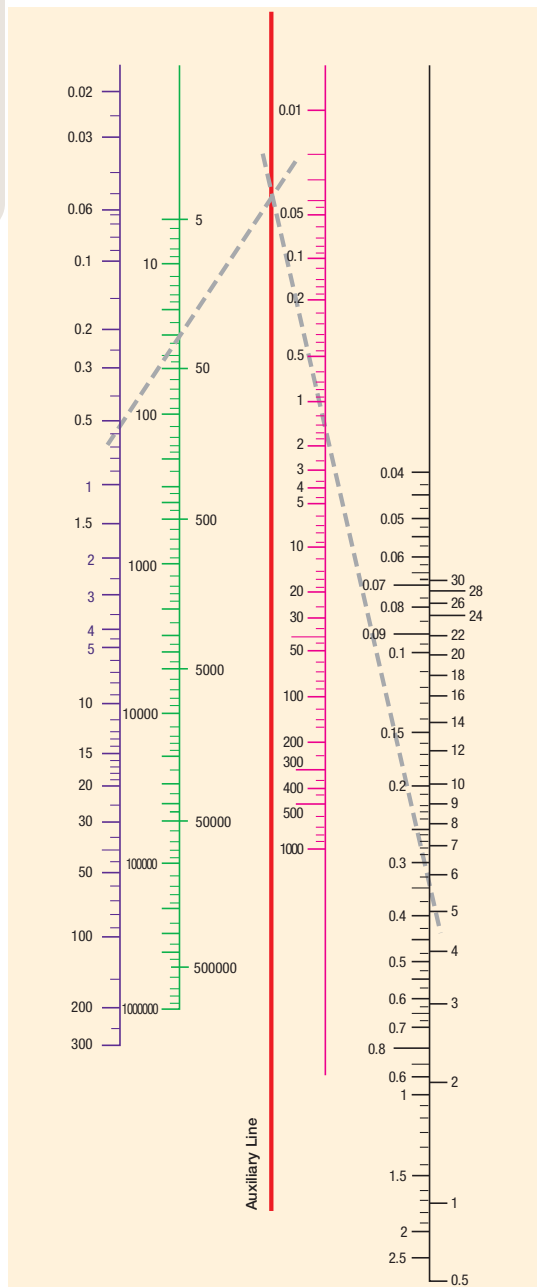

Données relatives à la vapeur sèche saturée

P_2 bar	Temp. °C	Vs m³/Kg	P_2 bar	Temp. °C	Vs m³/Kg
0,01	6,6	131,6	10	179	0,200
0,02	17,1	68,300	110	183,2	0,181
0,03	23,7	46,5	120	187,1	0,176
0,04	28,6	35,5	13	190,7	0,155
0,05	32,5	28,7	14	194,1	0,144
0,06	35,8	24,2	15	197,4	0,135
0,08	41,1	18,5	16	200,4	0,126
0,10	45,4	15	17	203,4	0,119
0,20	59,7	7,8	18	206,2	0,113
0,30	68,7	5,33	19	208,8	0,107
0,40	75,4	4,07	20	211,4	0,102
0,50	80,9	3,3	22	216,2	0,093
0,60	85,5	2,79	24	220,8	0,085
0,70	89,5	2,41	26	225	0,079
0,80	93	2,13	28	229	0,073
0,90	96,2	1,91	30	232,8	0,068
1	99,1	1,73	32	236,4	0,064
1,5	110,8	1,18	34	239,8	0,06
2	119,6	0,9	36	243,1	0,057
2,5	126,8	0,73	38	246,2	0,053
3	132,9	0,620	40	249,2	0,051
3,5	138,2	0,53	45	256,2	0,045
4	142,9	0,47	50	262,7	0,04
4,5	147,2	0,42	55	268,7	0,036
5	151,1	0,380	60	274,3	0,033
5,5	154,7	0,35	65	279,6	0,030
6	158,1	0,32	70	284,5	0,028
6,5	161,2	0,3	80	293,6	0,024
7	164,2	0,28	90	301,9	0,021
7,5	167	0,260	100	309,5	0,018
8	169,6	0,250	150	340,5	0,011
8,5	172,1	0,23	200	364,2	0,006
9	174,5	0,22	225	374	0,003
9,5	176,8	0,21			

K_v = Coefficient de débit

Q_v = Débit

Δp = Chute de pression

V_s = Volume spécifique

P_2 = Pression de sortie

TABLEAU DE CONVERSION DES VISCOSITÉS

Centistokes cSt mm ² /S	°Engler °E	Seconde Saybolt universelle sSu	Seconde Redwood N°1 SRW N°1
1	1	-	-
12	2	65	55
22	3	100	90
30	4	140	120
28	5	175	155
45	6	210	185
60	8	275	245
75	10	345	305
90	12	415	370
115	15	525	465
150	20	685	610
200	26	910	810
300	39	1 385	1 215
400	53	1 820	1 620
500	66	2 275	2 025
750	97	3 365	2 995
1 500	197	6 820	6 075

AUTRES FORMULES UTILES

Formules :

$$^{\circ}\text{C} = (^{\circ}\text{F} - 32) \times 5/9$$

$$^{\circ}\text{F} = (^{\circ}\text{C} \times 9/5) + 32$$

$$\text{m}^3/\text{h} = \text{l}/\text{min} \times 0,06$$

$$\text{l}/\text{min} = \text{m}^3/\text{h} \times 16,67$$

$$\text{m}^3/\text{s} = \text{m}^3/\text{h} \times 2,778 \times 10^{-4}$$

$$\text{m}^3/\text{s} = \text{l}/\text{min} \times 1,667 \times 10^{-5}$$

Exemples :

$$(167 ^{\circ}\text{F} - 32) \times 5/9 = 75 ^{\circ}\text{C}$$

$$(30 ^{\circ}\text{C} \times 9/5) + 32 = 86 ^{\circ}\text{F}$$

$$100 \text{ l}/\text{min} \times 0,06 = 6 \text{ m}^3/\text{h}$$

$$9 \text{ m}^3/\text{h} \times 16,67 = 150 \text{ l}/\text{min}$$

$$18 \text{ m}^3/\text{h} \times 2,778 \times 10^{-4} = 5 \text{ m}^3/\text{s}$$

$$479,904 \text{ l}/\text{min} \times 1,667 \times 10^{-5} = 8 \text{ m}^3/\text{s}$$

TABLEAU DES EMBASES POUR VANNES (Exemples)

Le tableau montre des exemples d'embases existantes et des vannes qui peuvent être associées. Pour plus de détails, reportez-vous aux schémas des embases dans les pages suivantes.

Référence des embases	488860.01 /.02/.03 /.04/.05	486162 /63/64	487165 /67/69	485635 /36/37	481168.02 /.04/.06 /.08/.10	481964.04 /.06/.08/.10	485291	485290	XGSPG1 /XGSPG2
Schéma	1	2	3	4	5	6	7	8	9
Référence de vanne									
131F4480	●								
131F4480		●							
131F46		●							
131F4650		●							
131M74	●								
131M74	●								
131M7450	●								
131M7450	●								
131M75	●								
131M7550	●								
132F43		●							
132F44		●							
132F46		●							
133F46		●							
133F4650		●							
2019F1									●
3019F1									●
301XGR									●
341F34				●					
341F3403				●					
341L11						●			
341L2190								●	
341L9101					●				
345F34				●					
347L11						●			
E131F26			●						
E131F43		●							
E131F4350		●							
E131F44		●							
E131F4450		●							
E133F43		●							
E133F4350		●							
E133F44		●							
E133F4450		●							
E331L21							●		

TABLEAU DES EMBASES POUR VANNES (Exemples)



Schéma 1

Nombre de vannes par assemblage	Nombres de référence	A mm	B mm	Poids g
1	488860-01	23,5	16,0 ± 0,1	25
2	488860-02	47,0	39,5 ± 0,1	45
3	488860-03	70,5	63,0 ± 0,1	70
4	488860-04	94,0	86,5 ± 0,1	120
5	488860-05	117,5	110,0 ± 0,1	120

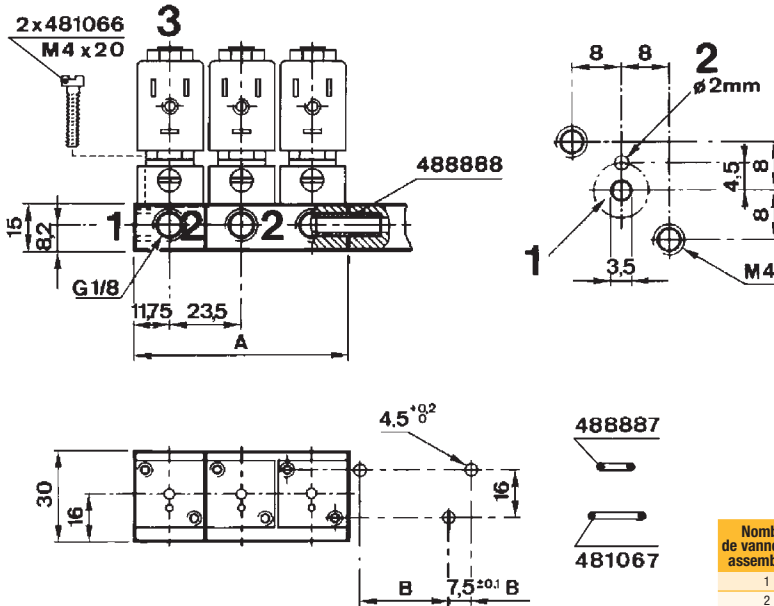

Schéma 2

Nombre de vannes par assemblage	Nombres de référence	A mm	B mm	Poids g
2	486162	93	79	150
3	486163	126	112	210
5	486164	192	178	420

TABLEAU DES EMBASES POUR VANNES (Exemples)

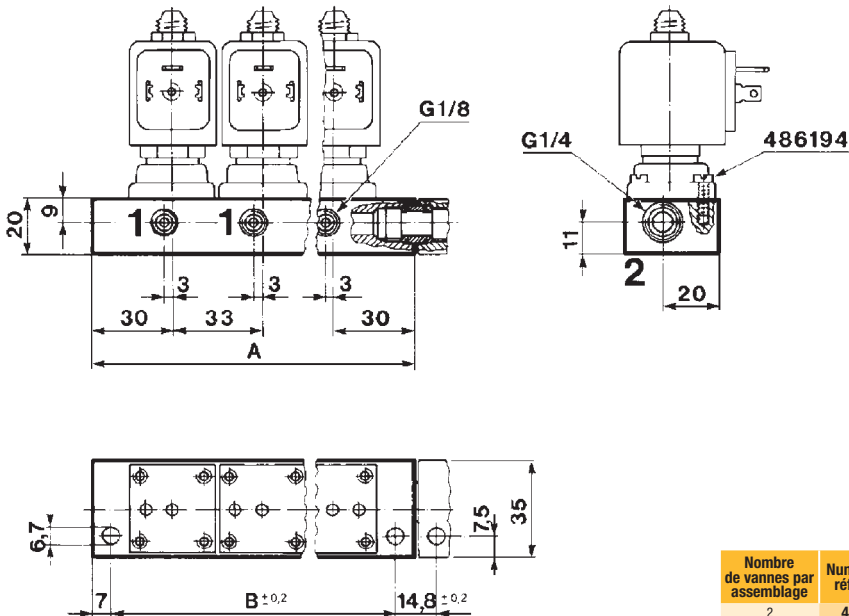

Schéma 3

Nombre de vannes par assemblage	Numéros de référence	A mm	B mm	Poids g
1	487165	56	44	85
2	487167	89	77	135
3	487169	188	176	300

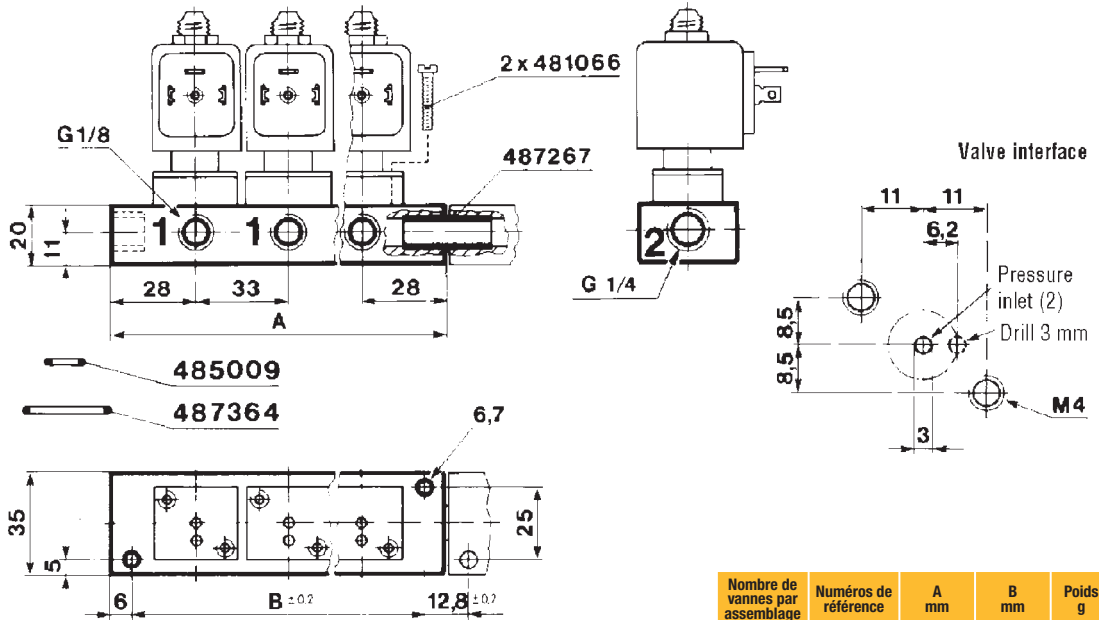

Schéma 4

Nombre de vannes par assemblage	Numéros de référence	A mm	B mm	Poids g
2	485635	128,2	115,0	1 000
3	485636	178,7	165,5	1 400
5	485637	279,7	266,5	2 250

TABLEAU DES EMBASES POUR VANNES (Exemples)

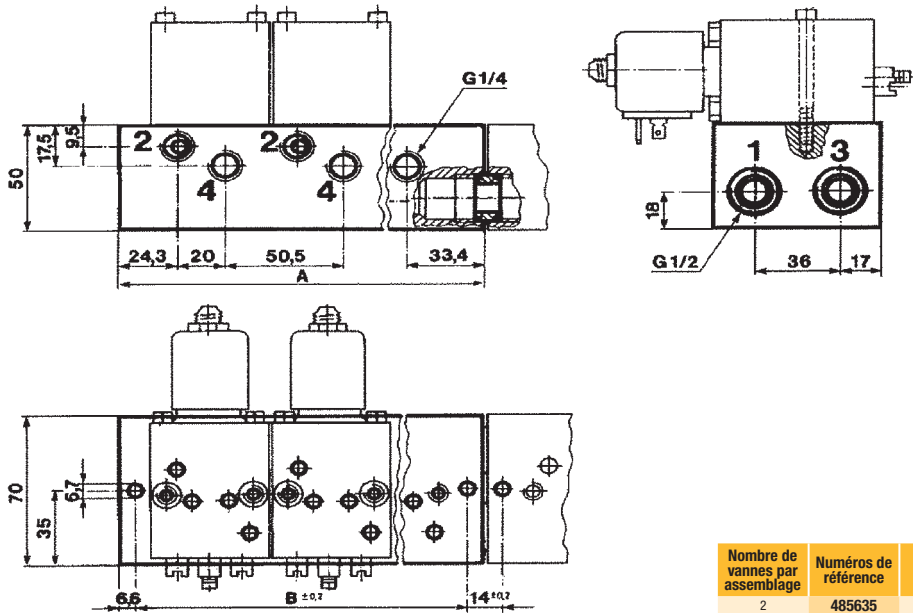

Schéma 5



Schéma 6

TABLEAU DES EMBASES POUR VANNES (Exemples)

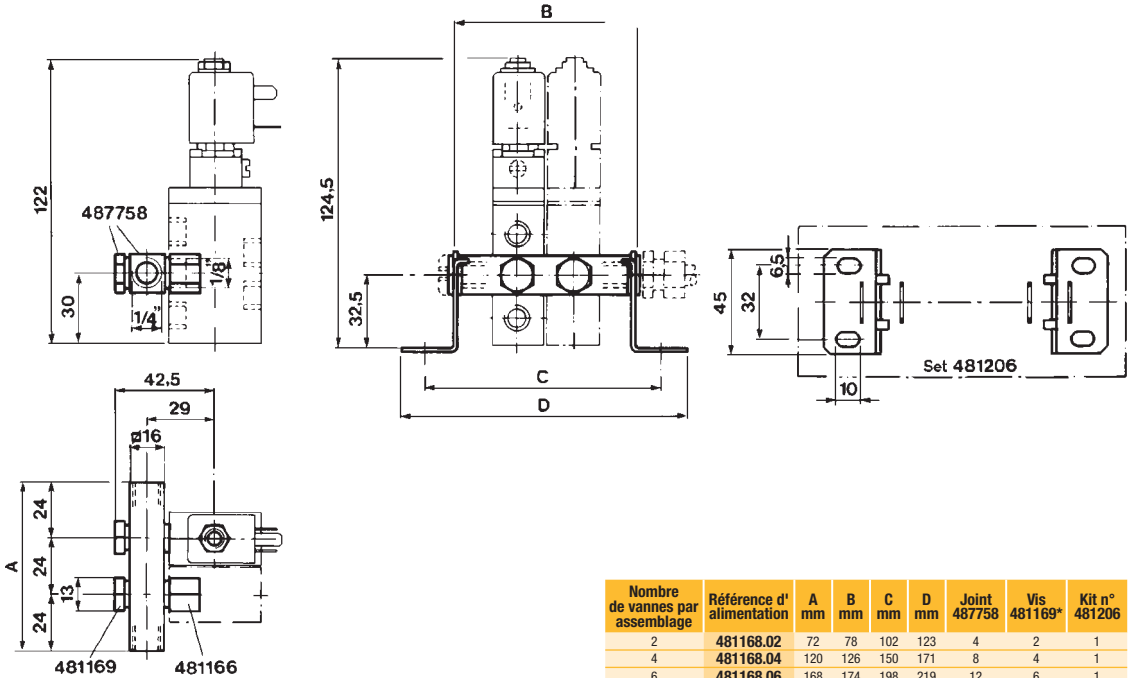
Sub-base 485291

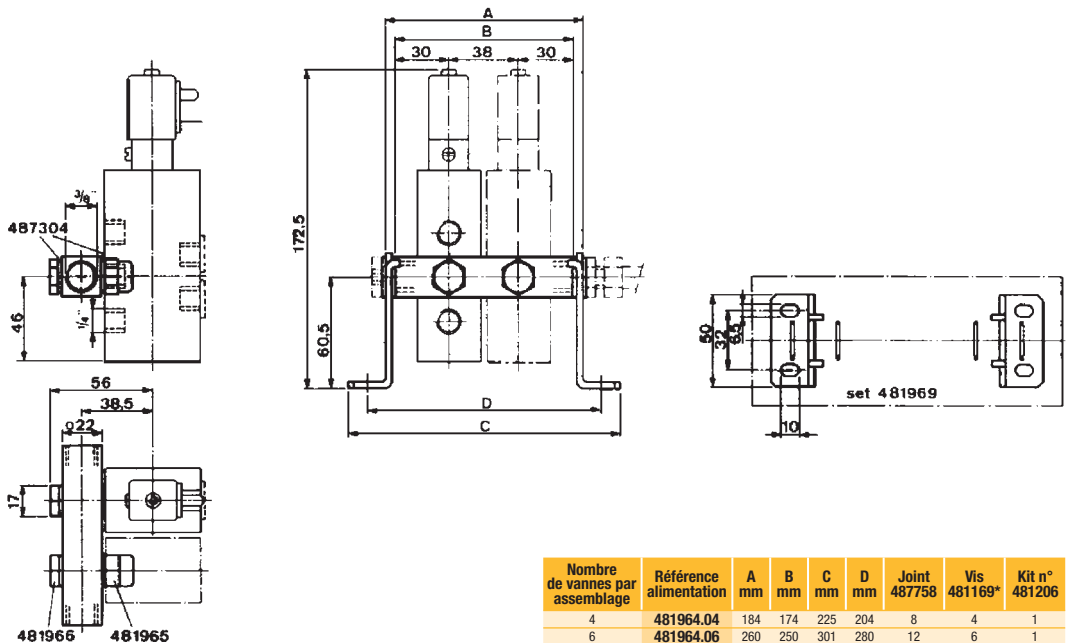

Schéma 7



Schéma 8

TABLEAU DES EMBASES POUR VANNES (Exemples)

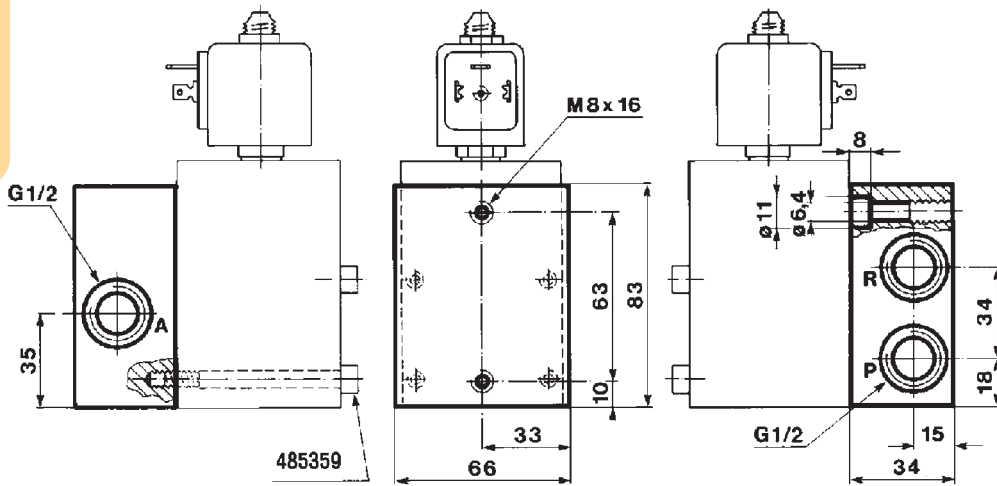

Schéma 9

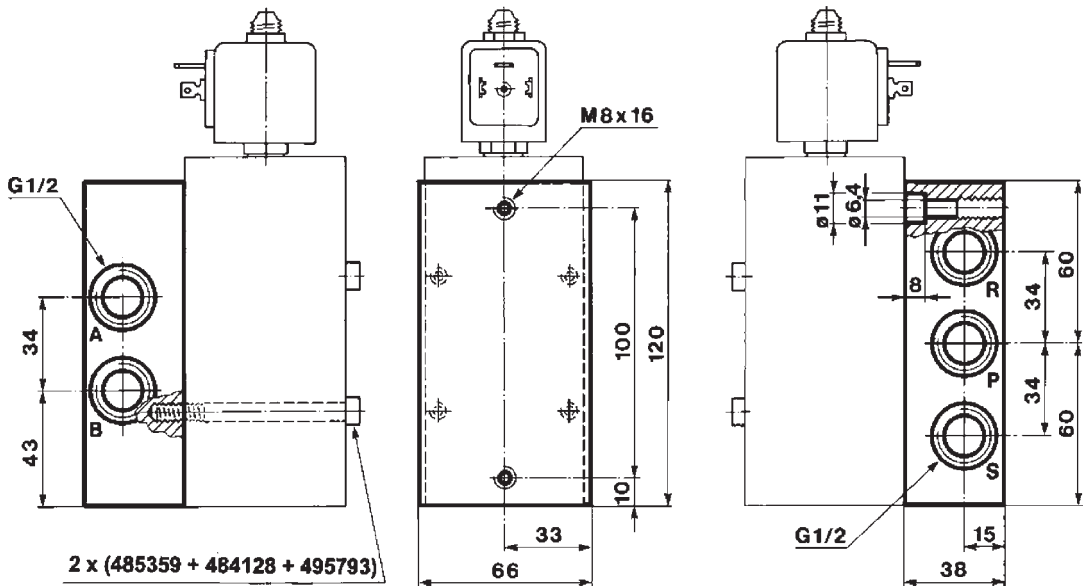
Raccord	Référence de kit	À utiliser avec	Quantité par boîte	Vis
1/8" G	XGSPG1	Toutes les versions	10	Inclus
1/4" G	XGSPG2	Toutes les versions	10	Inclus

INDEX PAR REFERENCE DE VALVE

Référence de valve	Page	Référence de valve	Page	Référence de valve	Page	Référence de valve	Page
U 033X0111	330	121K2423	184	122V8306	162	E 131K0358	210,302
U 033X5152	400	121K3106	36,86,144	PM 123AV	46	131K0397	210,214
U 033X5156	400	121K3206	36,86,144	PM 123CV	46	E 131K04	212,304
U 033X51561D	400	121K3303	128	PM 123DV	46	E 131K0450	212,304
U 033X5195	402	121K3306	36,86,144	PM 123IV	46	131K0490	210,302
U 033X5256	404	121K3321	184	PM 125BV	90	131K0497	212,304
U 033X52561D	404	E 121K45	36,86	PM 125CV.2	90	E 131K06	214,304
U 033X7156	402	E 121K4503	128	125K01	40,88	131K0648	272
PM 120.4AR	186	E 121K46	36,86	125K03	40	E 131K0650	214,304
PM 120.4IR	186	E 121K4603	128	PM 126YH	126	E 131K13	210
121F2523	188	121K6220	184	PM 126YT	126	E 131K14	210
E 121F43	42,146	E 121K63	34,142	PM 128GR	226	131K16	210
E 121F4302	42,92	E 121K64	34,144	PM 128IR	226	131K1650	210
121F4317	42	121K6423	184	PM 128ISV	226	E 131K63	216
E 121F44	42,146	E 121K65	32,142	PM 128IV	226	E 131K6350	216
E 121F4406	42,92	E 121K67	32,142	131.4BV	178	E 131K64	212
121F4417	42	121M13	32,84	131.4CG	180	E 131K6450	212
121F47	42	121M14	32,84	131.4FV	180	131M14	210,302
121F4706	42,146	121V5106	160	131.4GG	180	131M15	210,302
121F63	42,146	121V5112	160	131.4GV	180,182	131M74	228
121F64	42,146	121V5163	130,160	131AN	178	131M7450	228
121F67	42,146	121V5206	160	131B04	234	131M75	228
121G2320	184	121V5212	160	131B14	234	131M7550	228
121G2520	184	121V5263	130,160	E 131E03	216,306	131T21	216
121G2523	184	121V5306	158	E 131F26	238	131T2101	306
121K01	34,84	121V5363	130,158	E 131F43	230	131T22	216
121K0103	128	121V5397	160	E 131F4350	230	131T23	212
121K0106	34,84	121V5406	158	131F4397	312	131T2301	212
121K0113	128	121V5463	130,158	E 131F44	230	131T29	214
121K0150	34,84	121V5497	158	131F4410	228	131T2901	214
121K02	34,84	U 121V5595	170	E 131F4450	230	131V5306	252
121K0250	34,84	U 121V5596	170	131F4490	228	131V5363	252
E 121K03	34,142,144	U 121V55961D	170	131F4497	228	131V5397	252
E 121K0302	34,84	121V5706	158	131F46	230	131V5406	252
121K0323	128	121V5763	130,158	131F4650	230	131V5463	252
E 121K0352	34,84	122F44	44	U 131F5295	384	131V5490	252
121K0397	34	122K83	40	131F5406	236	131V5497	252
E 121K04	32,142	122K8306	40,86	U 131F5695	384	131X1101	334
E 121K0402	32,84	122K8321	188	U 131F56951D	384	U 131X1101	334
121K0497	32	122K8363	40,144	131IN	178	131X1131	334
E 121K07	32	122K84	40,144	131INDIN	178	U 131X1201	386
121K0706	32,84	122K8406	40	131IV	178	132F43	230
121K1302	32	122K8408	40,144	E 131K03	216	132F44	230
E 121K14	32,142	122K9321	188	E 131K0308	216,306	132F46	230
E 121K23	32,142	122K9363	40,144	E 131K0350	216,306	132K03	218

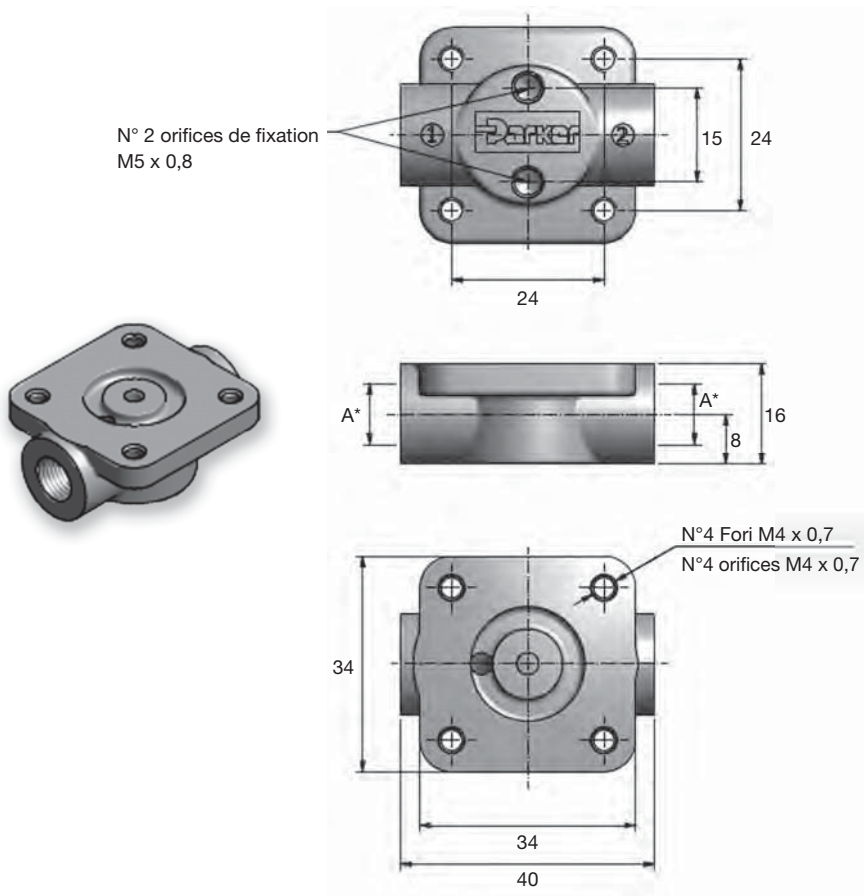
INDEX PAR REFERENCE DE VALVE

Référence de valve	Page	Référence de valve	Page	Référence de valve	Page	Référence de valve	Page
132K04	218	U 133X5192	378	PM 156.2IR	134	221G1630	50
132K06	218	U 133X5195	384	PM 158IH	126	221G1631	50
132T22	218	U 133X51951D	386	PM 158IT	126	221G17	52
132T23	218	U 133X5196	378	161.4AV	80	221G1703	132
132T2301	218	U 133X51961D	380	161.4BV	80	221G1710	52
132T29	308	U 133X5296	382	161.4EV	82	221G1730	52
E 133F43	232	U 133X52961D	382	PM 168.1AN	54	221G1731	114
E 133F44	232	U 133X7156	380	PM 168.1CN	54	221G21	52
E 133F4450	232	U 133X7195	386	PM 168.1DN	54	221G2103	114
133F46	232	U 133X7196	380	PM 168.1IN	54	221G2106	52
133F4650	312	PM 135AT	134	PM 169.1AN	68	221G2110	52
E 133K03	222	PM 135CT	136	PM 169.1CN	68	221G2130	52
E 133K0350	222	PM 135DT	136	PM 169.1DN	68	221G2131	114
E 133K04	222	PM 135IT	134	PM 169.1IN	68	221G2136	52
E 133K0450	222	135K03	310	PM 173AN	54	221G23	48
133K0497	222	135K04	224	PM 173IN	54	221G2330	48
E 133K05	222	PM 136.2FV	38	2019F1GRG7	202	221G25	48
E 133K06	222	PM 136YV	38	2019F1GVG7	202	221G2523	190
E 133K0650	222	PM 139AV	220	2019F1JRG7	202	221G2530	48
E 133K13	222	PM 139FV	220	2019F1JVG7	202	221G26	50
E 133K14	222	PM 139GV	220	2019F1LRG7	202,204	221G2630	50
E 133K16	222	PM 139LV	220	2019F1LVG7	204	221G27	52
133T21	222	PM 140.4AR	180	2019F1NRG7	204	221G2730	52
133T2101	224	PM 140.4DR	180	2019F1NVG7	204	221J3301E	198
133T23	222	PM 140CR	126,180	201LG1GVG2	166	221S10E	172
133T2301	222	PM 140DR	126,180	201LG1JVG2	166	221S10F	172
133V5306	254	PM 140IR	126,178	201LG1LVG2	166	221S15E	172
133V5363	254	PM 141AV	208	201LG2GVG2	166	221S15F	172
133V5406	254	PM 141BV	208	201LG2JVG2	166	221S20E	172
133V5463	254	PM 141FV	208	201LG2LVG2	166	221S20F	172
U 133V5595	376	PM 141GV	208	201LG2NVG7	166	221S25E	174
U 133V55951D	376	PM 146.3ABV	30,82	201LG2PVG7	166	221S25F	174
U 133V5695	376	PM 146.3KV	30,82	201LG3SVG7	168	3019F1GRG7	258
U 133V56951D	376	PM 146BV	28,80	201LG3UVG7	168	3019F1GVG7	258
U 133V7595	376	PM 146FV	28,30,80	201LG4SVG7	168	3019F1JRG7	258,260
U 133V7695	376	PM 146HV	30,80	201LG4UVG7	168	3019F1JVG7	260
133X01	314	PM 146WV	30,82	221G13	48	3019F1LRG7	260
U 133X01	314	PM 146YV	30,82	221G1303	132	3019F1LVG7	260
133X01001D	314	PM 151GV	38	221G1330	132	3019F1NRG7	262
U 133X0111	308	PM 151HV	38	221G15	48	3019F1NVG7	262
U 133X01111D	308	PM 153BV	182	221G1503	132	301XGFRTG7	258
U 133X0131	310	PM 153GV	182	221G1530	48	301XGFRTJ7	260
U 133X5152	378	PM 156.2AR	134	221G16	50	301XGFRTL7	260
U 133X5156	378	PM 156.2CR	136	221G1603	132	301XGFRTN7	262
U 133X51561D	378	PM 156.2DR	136	221G1610	50	301XGFVTG7	258

INDEX PAR REFERENCE DE VALVE

Référence de valve	Page	Référence de valve	Page	Référence de valve	Page	Référence de valve	Page
301XGFVTJ7	260	321K1536	268	322H35	70	E 341L02	292
301XGFVTL7	260,262	321K1537	268	322H36	72	341L04	294
301XGFVTN7	262	321K1543	266	322H71	70	341L05	294
321F2523	194	E 321K25	60,100	322H7106	70,152	341L11	290
E 321F32	76,110	321K31	56,98	322H73	70,152	E 341L1130	290
E 321F3202	76,154	321K3106	56	322H7306	70,152	U 341L1130	290
321F35	76	321K33	58,98	322H75	70,152	E 341L21	286
E 321G36	62,102	321K3306	58	322H7506	70,152	341L2190	286
E 321G3606	62	321K35	60,100	322K4106	108	341L9101	282
E 321G3610	118	321K3506	60	322K4306	108	341L9201	286
E 321G37	64,104	321K36	62,102	322K4506	108	341L9504	362
E 321G3706	64	321K3606	62	322K4606	108	341L9534	362
E 321G3710	120	321K37	64,104	322K4706	110	341L9594	364
321G3790	64	321K3706	64	325K4106	74	341L9597	364
E 321G38	64,104	321K4106	98,118	325K4306	74	341L9598	364
E 321G3806	64	321K4156	56	325K4506	74	341N01	340
E 321G3810	120	321K4306	98,118	325K4606	74	341N02	346
E 321G39	66,104	321K4356	58	325K4706	74	U 341N0250	396
E 321G3906	66	321K4506	100,118	E 331B01	240	341N03	350
E 321G3910	120	321K4556	100,118	331B02	248	341N04	350
321G3990	66	321K4606	102,118	E 331B21	242	341N05	344
E 321G40	66,104	321K4656	102,118	E 331B74	240	341N0502	346
E 321G4006	66	321K4706	104,120	331B7490	240	341N11	340
E 321G4010	120	321K4756	104,120	E 331L21	244	341N12	348
321G4090	66	E 321K63	148	331N03	336	341N21	340
E 321H11	56,148	322F35	76	331N04	336	341N2190	340
E 321H13	58,148	322F72	76	331N0402	336	341N22	348
E 321H15	60,150	322F7206	76,154	331N34	338	341N31	342
321H1590	60	322G36	72,108	331N3402	338	341N3102	342
E 321H21	148,192	322G3606	72	E 332B01	242	341N3108	342
E 321H23	148,192	322G3610	122	332B02	242	341N3128	342
321H2322	192	322G37	72,110	E 332B21	244	341N3130	342
E 321H25	150,194	322G3706	72	E 341B01	278	341N3190	342
321H2522	194	322G3710	122	341B02	276	341N3196	342
321H2523	194	322G38	72	E 341B21	278	341N3197	342
321H35	60	322G3806	72	341B34	276	341N32	348
321H36	62	322G3810	122	341B3403	276	341N3202	348
E 321K10	56,98	322G39	72,110	341B3440	276	U 341N3250	394
E 321K13	58,98	322G3906	72	341B3490	276	341N3290	344
E 321K1314	58,98	322G3910	122	E 341F21	278	U 341N3292	394
E 321K15	60,100	322G40	72	341F34	284	U 341N3295	394
E 321K1503	138	322G4006	72	341F3403	284	341N3296	344
E 321K1514	60,100	322G4010	122	341F3440	284	341N3297	344
321K1523	268	322G75	70,108	E 341L01	294	341N34	350
321K1535	266	322G7506	70,152	341L0197	294	341N35	346

INDEX PAR REFERENCE DE VALVE

Référence de valve	Page	Référence de valve	Page	Référence de valve	Page	Référence de valve	Page
341N3502	346	347L9101	282	542N03	372	7322BAH00	106
341P01	316	347L9201	288	547N03	370	7322BAN00	106
341P02	318	347N03	354	7321BAH00	94	7322BAV00	106
U 341P0250	388	347N04	356	7321BAN00	94	7322BCH00	106
341P03	318	347N11	352	7321BAN01	94	7322BCN00	106
341P04	322	347N12	354	7321BAV00	94	7322BCV00	106
341P21	316	347N31	352	7321BCH00	94	7322BDH00	106
341P2108	316	347N3190	352	7321BCN00	94	7322BDN00	106
341P2190	318	347N3197	352	7321BCN01	94	7322BDV00	106
341P2197	316	347N32	354	7321BCN02	116	7322BEH00	106
341P22	320	U 347N3250	398	7321BCV00	94	7322BEN00	106
341P2290	320	347N33	354	7321BDH00	94	7322BFH00	106
341P2297	320	347N34	356	7321BDN00	94	7322BFN00	106
U 341P3250	388	347P01	324	7321BDN01	94	7322BGH00	106
U 341P3295	390	347P02	326	7321BDN02	116	7322BGN00	106
341P3295	390	347P03	326	7321BDV00	94	7322BIH00	106
341P33	318	347P04	328	7321BEH00	96	7322BIN00	106
341P34	322	347P21	324	7321BEN00	96	7322BIV00	106
342N03	358	347P2190	324	7321BEN01	96	7322BLN06	106
342N11	358	347P2197	324	7321BEN02	116	7322BMN06	106
342N3197	358	347P22	326	7321BFH00	96	N74.4AV	28
342N33	358	U 347P3250	392	7321BFN00	96	N74.4VA.5	28
343N03	360	U 347P3295	392	7321BFN01	96	N74.4BV	28
345B04	280	347P33	326	7321BFN02	116	N74.4FV	28
345B24	280	347P34	328	7321BGH00	96	N74.4IV	28
345B34	280	421F35	76	7321BGN00	96	N74.4WV	30
345F34	284	U 441P3250	388	7321BGN01	96	N79.4AV	208
345L01	296	531N03	366	7321BGN02	116	N79.4IV	208
345L21	288	531N04	366	7321BIH00	94	N79.6AV	208
345N31	362	541L01	298	7321BIN00	94	N79.6BV	208
345P21	328	541N01	368	7321BIN01	94	N79.6IV	208
347L04	288	541N0108	368	7321BIV00	94		
347L11	292	541N03	370	7321BLN02	116		
E 347L1130	292	541N04	370	7321BMN02	116		

INDEX PAR N° DE COMMANDE DE VALVE

N° Commande Valve	Page	N° Commande Valve	Page	N° Commande Valve	Page	N° Commande Valve	Page
360451J	186	364010	182	390580	180	398000	28
360452J	186	364035	182	390605	180	398001	28
360469	90	364520	134	390625	180	398003	28
360470	126	364525	134	390626	180	398006	30
360475	126	364530	136	390650	182	398007	30
360479J	226	364535	136	390668	180	398008	30
360480J	226	364880J	126	390700	180	398010	30
360490J	226	364884J	126	390705	182	398012	30
360506	226	366501	54	390718	182	398013	28
361810	46	366511	54	390720	182	398014	28
361850	46	366521	54	390721	182	398016	28
361910	46	366531	54	390725	180	398017	28
361950	46	366601	68	390802	180	398018	28
362262	134	366606	68	390803	180	398022	28
362263	134	366611	68	390805	180	398024	28
362264	136	366616	68	390813	180	398026	28
362265	136	366770	54	390874	180	398028	28
362290	38	366775	54	390875	180	398029	28
362410J	220	390005	178	390878	180	398030	28
362460J	220	390034	178	390895	180	398034	28
362470J	220	390085	178	390915	180	398038	28
362475J	220	390086	178	390945	180	398042U	28
362496J	126, 178	390088	178	390975	180	398046U	28
362510J	180	390089	178	390995	180	398048	28
362518J	126, 180	390120	178	390997	180	398050	28
362524J	126, 180	390145	178	392169	82	398052	28
362530J	180	390150	178	392170	82	398100	208
362560J	208	390165	178	392173	82	398102	208
362570J	208	390195	178	392335	80	398104	208
362620J	208	390215	178	392349	80	398108	208
362630J	208	390216	178	392355	80	398110	208
363282	38	390300	178	392366	80	398112	208
363378	28, 80	390405	178	392370	80	398114	208
363380	28, 30	390445	178	392372	80	398120	208
363390	30, 80	390457	178	392388	80	398122	208
363439	30, 82	390458	178	392389	80	398130U	208
363444	30, 82	390465	178	392395	82	398132	208
363457	30, 82	390495	178	392396	82	398134U	208
363467	30, 82	390505	178	392408	82	398136U	208
363475	38	390525	180	392409	82	398138	208
363570	38	390560	180	397146J	90	398142	208

INDEX PAR N° DE COMMANDE DE VALVE

N° Commande Valve	Page	N° Commande Valve	Page	N° Commande Valve	Page
398152	208	443793W	96	443811W	106
443776W	94	443794W	96	444492W	94
443777W	94	443795W	96	444494W	94
443778W	94	443796W	116	444497W	94
443779W	94	443797W	96	444499W	106
443780W	94	443798W	96	444500W	106
443781W	94	443799W	96	444501W	106
443782W	94	443800W	116	444502W	106
443783W	94	443801W	96	444503W	106
443784W	116	443802W	116	444513W	106
443785W	94	443803W	116	444576W	106
443786W	94	443804W	94	444600W	106
443787W	94	443805W	106	444601W	106
443788W	116	443806W	106	444602W	106
443789W	94	443807W	106	444603W	106
443790W	96	443808W	106	444604W	106
443791W	96	443809W	106	444605W	106
443792W	116	443810W	106		

**AVERTISSEMENT – RESPONSABILITE DE L'UTILISATEUR**

LA DEFECTUOSITE OU LA SELECTION OU L'USAGE ABUSIF DES PRODUITS DECRITS DANS LE PRESENT DOCUMENT OU D'ARTICLES ASSOCIES PEUT ENTRAINER LA MORT, DES BLESSURES ET DES DOMMAGES MATERIELS.

- Ce document et d'autres informations de Parker-Hannifin Corporation, ses filiales et distributeurs autorisés, proposent des options de produit et de système destinées aux utilisateurs possédant de solides connaissances techniques.
- En procédant à ses propres analyses et essais, l'utilisateur est seul responsable de la sélection définitive du système et des composants, au même titre qu'il lui incombe de veiller à la satisfaction des exigences en matière de performances, endurance, entretien, sécurité et avertissement. L'utilisateur doit analyser tous les aspects de l'application, suivre les normes applicables de l'industrie et les informations concernant le produit dans le catalogue de produits actuel et dans tout autre document fourni par Parker, ses filiales ou distributeurs agréés.
- Dans la mesure où Parker ou ses filiales ou distributeurs agréés fournissent des options de système ou de composant se basant sur les données ou les spécifications indiquées par l'utilisateur, c'est à celui-ci qu'incombe la responsabilité de déterminer si ces données et spécifications conviennent et sont suffisantes pour toutes les applications et utilisations raisonnablement prévisibles des composants ou des systèmes.

Les technologies Parker du mouvement et du contrôle

L'objectif numéro un de Parker est d'apporter à ses clients une solution à toutes leurs demandes. Nous les aidons à améliorer leur rentabilité en leur fournissant les systèmes répondant le mieux à leurs besoins. Nous considérons toutes les facettes de leurs applications pour pouvoir leur apporter de la valeur ajoutée. Quel que soit le besoin en matière de transmissions ou de contrôle du mouvement, Parker a l'expertise, la gamme de produits et une présence mondiale inégalées. Parker est la seule entreprise à maîtriser parfaitement les technologies de mouvement et de contrôle.

Pour davantage de renseignements, composez le 00800 27 27 5374.



Aérospatiale

Principaux marchés

Services après-vente
Transports commerciaux
Moteurs d'avions
Aviation commerciale et d'affaires
Hélicoptères
Lanceurs
Avions militaires
Missiles
Production d'énergie
Avions de transport régionaux
Véhicules volants sans pilote

Principaux produits

Systèmes et composants de commandes de vol
Systèmes et composants moteurs
Systèmes de transport des fluides
Dispositifs de contrôle de débit et d'atomisation
Systèmes et composants combustibles
Systèmes d'inertage par production d'azote
Systèmes et composants pneumatiques
Gestion thermique
Roues et freins



Climatisation et réfrigération

Principaux marchés

Agriculture
Climatisation de locaux
Machines de construction
Agroalimentaire
Machines industrielles
Sciences de la vie
Pétrole et gaz
Réfrigération de précision
Process
Réfrigération
Transport

Principaux produits

Accumulateurs
Actionneurs avancés
Régulation pour le CO2
Contrôleurs électroniques
Déshydrateurs-filtres
Robinets d'arrêt manuels
Échangeurs thermiques
Tuyaux et embouts
Régulateurs de pression
Distributeurs de réfrigérant
Soupapes de sécurité
Pompes intelligentes
Vannes électromagnétiques
Détendeurs thermostatiques



Hydraulique

Principaux marchés

Chariots élévateurs
Agriculture
Énergies alternatives
Machines de construction
Exploitation forestière
Machines industrielles
Machines-outils
Applications marines
Manutention
Exploitation minière
Pétrole et gaz
Production d'énergie
Véhicules de ramassage d'ordures
Énergies renouvelables
Systèmes hydrauliques pour camions
Équipement pour gazon

Principaux produits

Accumulateurs
Appareils à cartouches
Actionneurs électro-hydrauliques
Interfaces homme-machine
Systèmes de propulsion hybride
Vérins et accumulateurs hydrauliques
Moteurs et pompes hydrauliques
Systèmes hydrauliques
Vannes et commandes hydrauliques
Direction hydrostatique
Circuits hydrauliques intégrés
Prises de force
Blocs d'alimentation
Actionneurs rotatifs
Capteurs



Pneumatique

Principaux marchés

Aérospatiale
Manutention et convoyeurs
Automatisation d'usine
Médecine et sciences de la vie
Machines-outils
Machines d'emballages
Transport et automobile

Principaux produits

Traitement de l'air
Raccords et vannes en laiton
Collecteurs
Accessoires pneumatiques
Pincés et vérins pneumatiques
Vannes et commandes pneumatiques
Coupleurs à déconnexion rapide
Vérins rotatifs
Tuyaux caoutchouc et embouts
Extrusions structurelles
Tuyaux thermoplastique et embouts
Générateurs de vide, préhenseurs, pressostats et vacuostats



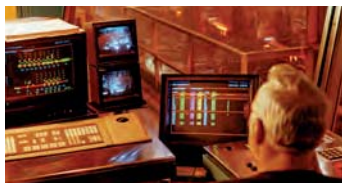

Électromécanique

Principaux marchés Principaux produits

Aérospatiale	Systèmes d'entraînement
Automatisation d'usine	CA/CC
Médecine et sciences de la vie	Actionneurs électriques, robots sur portique et systèmes de guidage
Machines-outils	Actionneurs électro-hydrostatiques
Machines d'emballages	Actionneurs électro-mécaniques
Papeterie	Interfaces homme-machine
Machines de fabrication et de transformation du plastique	Moteurs linéaires
Métallurgie	Moteurs pas-à-pas, servomoteurs, systèmes d'entraînement et commandes
Semiconducteurs et électronique	Extrusions structurelles
Textile	
Fils et câbles	



Filtration

Principaux marchés Principaux produits

Aérospatiale	Générateurs de gaz pour l'analyse
Agroalimentaire	Filtres à gaz et à air comprimé
Équipement et usines industrielles	Systèmes et filtration d'huile, de combustible et d'air de moteur
Sciences de la vie	Systèmes de surveillance de l'état des fluides
Applications marines	Filtres hydrauliques et de lubrification
Équipement mobile	Générateurs d'azote, d'hydrogène et d'air zéro
Pétrole et gaz	Filtres
Production d'énergie et énergies renouvelables	Filtres à membrane et à matière fibreuse
Process	Microfiltration
Transport	Filtration d'air stérile
Épuration de l'eau	Dessalement d'eau, systèmes et filtres de purification



Traitement du gaz et des fluides

Principaux marchés Principaux produits

Chariots élévateurs	Vannes d'arrêt
Agriculture	Raccords pour distribution de fluides basse pression
Manipulation de produits chimiques en vrac	Câbles ombilicaux en eaux profondes
Machines servant à la construction	Equipements de diagnostic
Agroalimentaire	Coupleurs
Acheminement du gaz et du combustible	Tuyaux industriels
Machines industrielles	Systèmes d'amarrage et câbles d'alimentation
Sciences de la vie	Tubes et accouplements
Applications marines	PTFE
Exploitation minière	Coupleurs rapides
Mobile	Tuyaux thermoplastique et embouts
Pétrole et gaz	Raccords et adaptateurs de tubes
Énergies renouvelables	Tubes et raccords en plastique
Transports	



Maîtrise des procédés

Principaux marchés Principaux produits

Carburants alternatifs	Appareils d'analyse
Biopharmaceutique	Produits et systèmes de traitement d'échantillons analytiques
Produits chimiques/raffinage	Raccords et vannes pour injection chimique
Agroalimentaire	Raccords, vannes et pompes de distribution de polymère fluoré
Applications marines et construction navale	Raccords, vannes et régulateurs de gaz très pur
Secteur médical et dentaire	Raccords, vannes et régulateurs de gaz très pur
Semiconducteurs	Contrôleurs/régulateurs industriels de débit massique
Énergie nucléaire	Raccords permanents sans soudure
Prospection pétrolière offshore	Contrôleurs de débit et régulateurs industriels de précision
Pétrole et gaz	Dispositifs double isolement et purge pour contrôle de process
Pharmaceutique	Raccords, vannes, régulateurs et vannes à plusieurs voies pour contrôle de process
Production d'énergie	
Papeterie	
Acier	
Eau/eaux usées	



Étanchéité et protection contre les interférences électromagnétiques

Principaux marchés Principaux produits

Aérospatiale	Joints d'étanchéité dynamiques
Chimie et Pétrochimie	Joints toriques élastomère
Domestique	Conception et assemblage d'appareils électromécaniques
Hydraulique et pneumatique	Blindage EMI
Industrie	Pièces extrudées et tronçonnées
Technologies de l'information	Joints métalliques haute température
Sciences de la vie	Pièces en élastomère insérées et homogènes
Semiconducteurs	Fabrication et assemblage de dispositifs médicaux
Applications militaires	Joints composites métal/plastique
Pétrole et gaz	Fenêtres optiques scellées
Production d'énergie	Extrusions et tubes silicone
Énergies renouvelables	Gestion thermique
Télécommunications	Amortissement des vibrations
Transports	

Parker dans le monde

Europe, Moyen Orient, Afrique

AE - Émirats Arabes Unis, Dubai
Tél: +971 4 8127100
parker.me@parker.com

AT - Autriche, Wiener Neustadt
Tél: +43 (0)2622 23501-0
parker.austria@parker.com

AT - Europe de l'Est, Wiener Neustadt
Tél: +43 (0)2622 23501 900
parker.easteurope@parker.com

AZ - Azerbaïdjan, Baku
Tél: +994 50 2233 458
parker.azerbaijan@parker.com

BE/LU - Belgique, Nivelles
Tél: +32 (0)67 280 900
parker.belgium@parker.com

BY - Biélorussie, Minsk
Tél: +375 17 209 9399
parker.belarus@parker.com

CH - Suisse, Etoy
Tél: +41 (0)21 821 87 00
parker.switzerland@parker.com

CZ - République Tchèque, Klecany
Tél: +420 284 083 111
parker.czechrepublic@parker.com

DE - Allemagne, Kaarst
Tél: +49 (0)2131 4016 0
parker.germany@parker.com

DK - Danemark, Ballerup
Tél: +45 43 56 04 00
parker.denmark@parker.com

ES - Espagne, Madrid
Tél: +34 902 330 001
parker.spain@parker.com

FI - Finlande, Vantaa
Tél: +358 (0)20 753 2500
parker.finland@parker.com

FR - France, Contamine s/Arve
Tél: +33 (0)4 50 25 80 25
parker.france@parker.com

GR - Grèce, Athènes
Tél: +30 210 933 6450
parker.greece@parker.com

HU - Hongrie, Budapest
Tél: +36 23 885 470
parker.hungary@parker.com

IE - Irlande, Dublin
Tél: +353 (0)1 466 6370
parker.ireland@parker.com

IT - Italie, Corsico (MI)
Tél: +39 02 45 19 21
parker.italy@parker.com

KZ - Kazakhstan, Almaty
Tél: +7 7272 505 800
parker.easteurope@parker.com

NL - Pays-Bas, Oldenzaal
Tél: +31 (0)541 585 000
parker.nl@parker.com

NO - Norvège, Asker
Tél: +47 66 75 34 00
parker.norway@parker.com

PL - Pologne, Warszawa
Tél: +48 (0)22 573 24 00
parker.poland@parker.com

PT - Portugal, Leca da Palmeira
Tél: +351 22 999 7360
parker.portugal@parker.com

RO - Roumanie, Bucarest
Tél: +40 21 252 1382
parker.romania@parker.com

RU - Russie, Moscou
Tél: +7 495 645-2156
parker.russia@parker.com

SE - Suède, Spånga
Tél: +46 (0)8 59 79 50 00
parker.sweden@parker.com

SK - Slovaquie, Banská Bystrica
Tél: +421 484 162 252
parker.slovakia@parker.com

SL - Slovénie, Novo Mesto
Tél: +386 7 337 6650
parker.slovenia@parker.com

TR - Turquie, Istanbul
Tél: +90 216 4997081
parker.turkey@parker.com

UA - Ukraine, Kiev
Tél: +380 44 494 2731
parker.ukraine@parker.com

UK - Royaume-Uni, Warwick
Tél: +44 (0)1926 317 878
parker.uk@parker.com

ZA - Afrique du Sud, Kempton Park
Tél: +27 (0)11 961 0700
parker.southafrica@parker.com

Amérique du Nord

CA - Canada, Milton, Ontario
Tél: +1 905 693 3000

US - USA, Cleveland
Tél: +1 216 896 3000

Asie Pacifique

AU - Australie, Castle Hill
Tél: +61 (0)2-9634 7777

CN - Chine, Shanghai
Tél: +86 21 2899 5000

HK - Hong Kong
Tél: +852 2428 8008

IN - Inde, Mumbai
Tél: +91 22 6513 7081-85

JP - Japon, Tokyo
Tél: +81 (0)3 6408 3901

KR - Corée, Seoul
Tél: +82 2 559 0400

MY - Malaisie, Shah Alam
Tél: +60 3 7849 0800

NZ - Nouvelle-Zélande, Mt Wellington
Tél: +64 9 574 1744

SG - Singapour
Tél: +65 6887 6300

TH - Thaïlande, Bangkok
Tel: +662 186 7000-99

TW - Taiwan, Taipei
Tél: +886 2 2298 8987

Amérique du Sud

AR - Argentine, Buenos Aires
Tél: +54 3327 44 4129

BR - Brésil, Sao Jose dos Campos
Tel: +55 800 727 5374

CL - Chili, Santiago
Tél: +56 2 623 1216

MX - Mexico, Apodaca
Tél: +52 81 8156 6000

Centre européen d'information produits

Numéro vert : 00 800 27 27 5374

(depuis AT, BE, CH, CZ, DE, DK, EE, ES, FI, FR, IE, IL, IS, IT, LU, MT, NL, NO, PL, PT, RU, SE, SK, UK, ZA)

US Product Information Centre

Toll-free number: 1-800-27 27 537

www.parker.com

Votre distributeur Parker

